

SPECIFY CATALOG NO. AND SERIAL NO. WHEN ORDERING PARTS		REVISED BULLETIN	DATE
14.4 VOLT 1/2" SQUARE IMPACT WRENCH			Oct. 2011
CATALOG NO.	9083-20	STARTING SERIAL NO.	400A
		WIRING INSTRUCTION 58-01-1835	

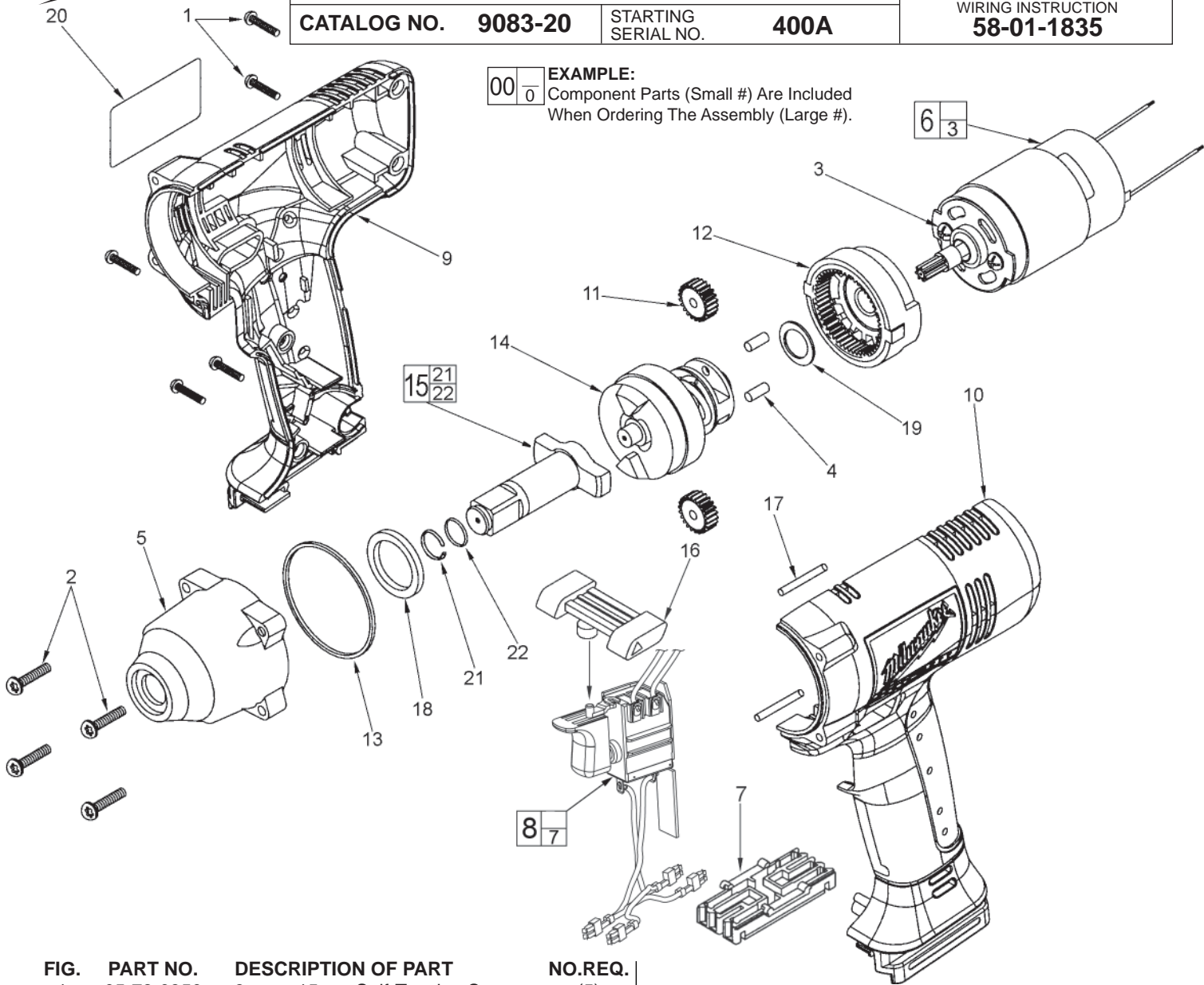

FIG.	PART NO.	DESCRIPTION OF PART	NO.REQ.
1	05-78-0350	3mm x 15mm Self-Tapping Screw	(5)
2	05-78-0580	4mm x 20mm Self-Tapping Screw	(4)
3	05-81-0409	4mm x 8mm Pan Hd. Machine Screw	(2)
4	06-65-0970	4mm x 10mm Pin	(2)
5	14-30-0580	Gearcase Assembly	(1)
6	14-50-0720	Motor Assembly (Includes item 3)	(1)
7	22-56-0195	Connector Block	(1)
8	23-66-2245	Switch Assembly	(1)
9	31-44-1190	Right Housing	(1)
10	31-44-1195	Left Housing	(1)
11	32-62-0230	Planet Gear	(2)
12	32-65-0100	Ring Gear Assembly	(1)
13	34-40-0960	Rubber Ring	(1)
14	38-50-0930	Middle Shaft Assembly	(1)
15	42-06-0485	Output Shaft Assembly	(1)
16	45-24-0510	Forward/Reverse Lever	(1)
17	45-06-0760	0.8mm x 20mm Seal	(2)
18	45-88-0845	Washer	(1)
19	45-88-0955	Washer	(1)
20	12-20-1210	Service Nameplate Kit	(1)
21	34-60-1040	Retaining Ring	(1)
22	34-40-0980	O-Ring	(1)

WARNING
SWITCH POLARITY SENSITIVE
 If wired incorrectly with connector block #7, switch **will be** damaged and destroyed! Refer to Service Wiring Diagram 58-01-1835.

FIG. LUBRICATION:
 6 Lightly coat the pinion area of the motor assembly with Type "L" grease, No. 49-08-4170.
 12 Lightly coat the inside surface of the ring gear assembly with Type "L" grease.
 4,11, 14,15,19 Lightly coat the surfaces of the pins, planet gears, middle shaft assembly, output shaft assembly and washer with Type "L" grease.