

815A Self-Opening Through-Head Oiling Die Head

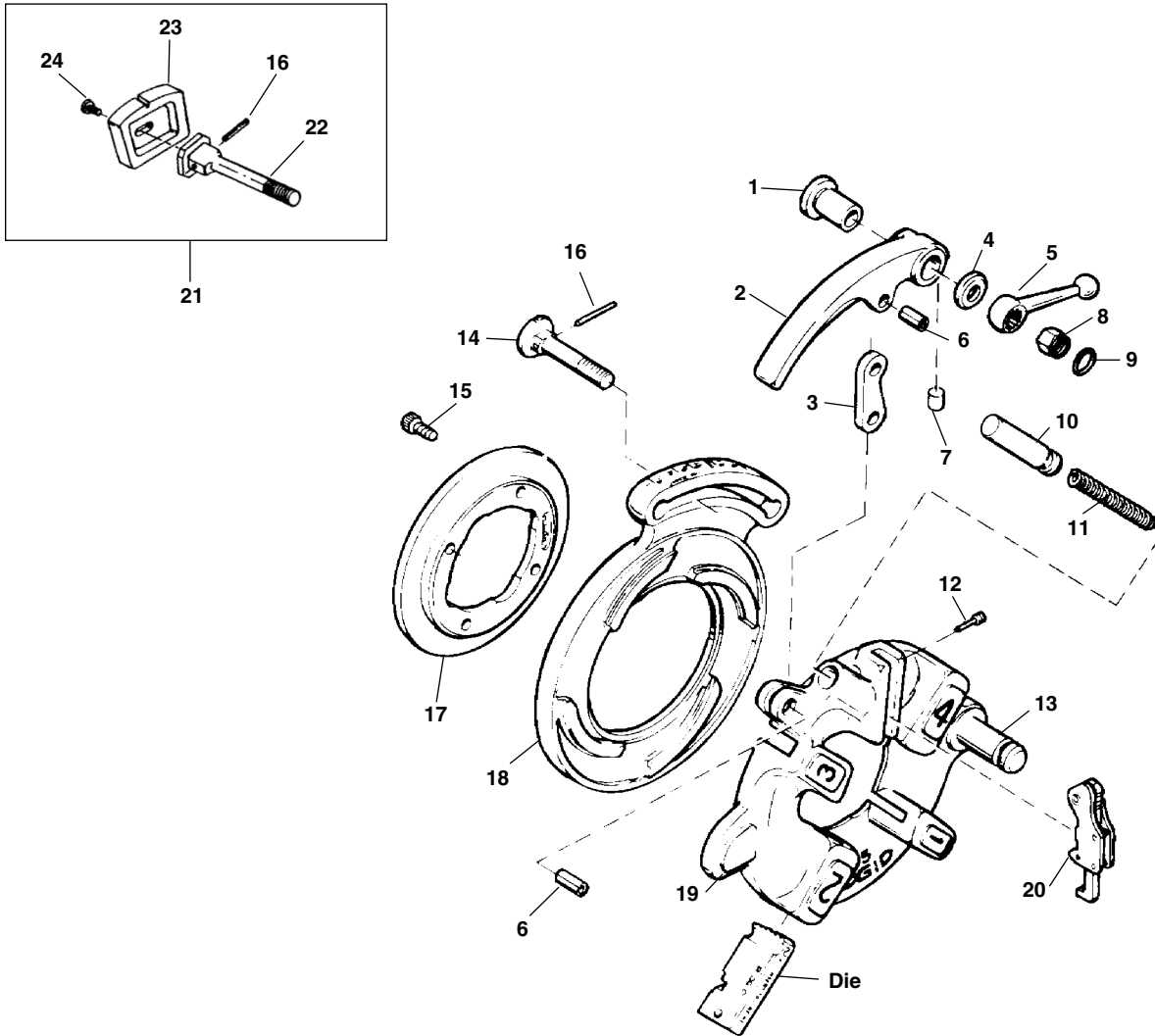

**NOTE: Order parts by Catalog Number only.
DO NOT order by Reference Number.**

Ref. No.	Catalog No.	Description	Ref. No.	Catalog No.	Description
—	97075	815A Self-Opening (Through-Head-Oiling) Die Head (NPT)	13	59832	Post
	97080	815A Self-Opening (Through-Head-Oiling) Die Head (BSPT)	14	44235	Lock Screw
1	44240	Bushing	15	32205	Screw (4)
2	43830	Throw-Out Lever	16	45050	Pin
3	44265	Throw-Out Link	17	97020	Retaining Ring
4	44245	Washer	18	40942	Cam Plate (815A NPT)
5	44260	Clamp Lever		97040	Cam Plate (815A BSPT)
6	44270	Roll Pin (2)	19	40932	Head w/Post
7	45055	Insert	20	44285	Trigger Assembly
8	44250	Nut		32982	Adj. Trigger Assy. (Europe)
9	44255	Retaining Ring		45327	Trigger Assy. (Europe)
10	44275	Throw-Out Plunger	21	45332	Gauge Plate Assy.
11	11565	Spring	22	46722	Adj. Lock Screw
12	44290	Trigger Screw	23	46717	Gauge Plate
			24	47147	Buttonhead Screw

NOTE: Early Style 815/845 parts interchangeable with 815A NPT
Early Style 855 parts interchangeable with 815A BSPT