

. - F 013 730 001 - 7300www.powertools-aftersaleservice.com**BOSCH**

Item	Part Number	Description	Illustration	Price	Quantity	Price Group
1	2 610 024 705	Housing	1	-,-	1	-
2	2 610 916 207	Motor	1	-,-	1	28
4	2 610 916 208	Mains switch	1	-,-	1	23
5	2 610 024 706	Housing Cover	1	-,-	1	-
8	2 610 041 704	Label	1	-,-	1	-
9	2 610 011 402	Adhesive Label	1	-,-	1	-
19	2 610 347 948	Screw	1	-,-	2	11
25	2 610 916 357	Cover	1	-,-	1	10
26	2 610 014 582	Nut	1	-,-	1	12
27	2 615 110 480	Collet 1/8"	1	-,-	1	15
91	2 610 919 034	Battery 4,8V	1	-,-	1	-
650	2 610 930 692	Chuck Wrench	1	-,-	1	13
655	2 610 027 973	Battery Charger	1	-,-	1	28
824	2 610 917 263	Locking Lever	1	-,-	1	12

Illustration - Type E

F 013 730 001
Stand }
Issue } 16-12-22 **Fig./Abb. 1**

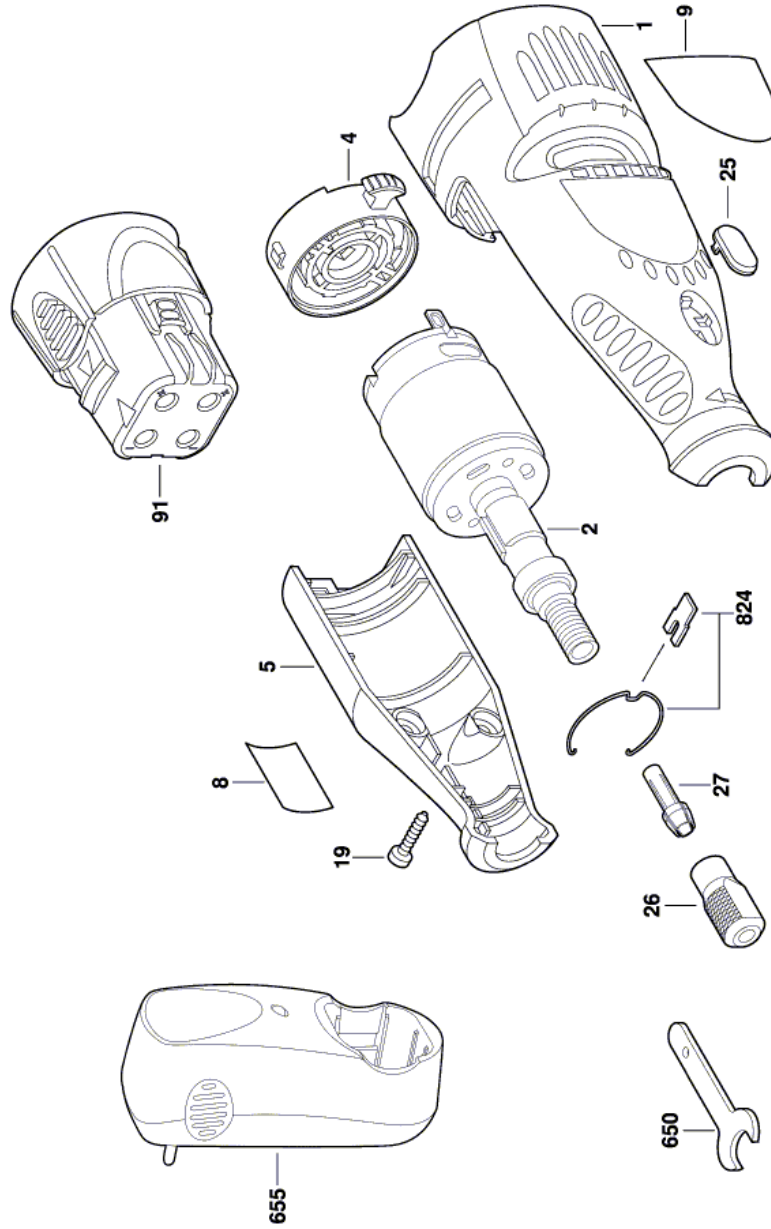

Änderungen vorbehalten
Modifications reserved
Modificacions reserves
Salvo modificaciones

Information subject to change without further notice.