



# SERVICE PARTS LIST

**BULLETIN NO.**  
**54-44-0633**

SPECIFY CATALOG NO. AND SERIAL NO. WHEN ORDERING PARTS		REVISED BULLETIN	DATE
<b>18 GAUGE SHEAR</b>		54-44-0632	Mar. '94
CATALOG NO. <b>6855</b>	STARTING SERIAL NO. <b>711A</b>	WIRING INSTRUCTION	
		<b>58-01-0309</b>	

**EXAMPLE:**



Component Parts (Small #) Are Included When Ordering The Assembly (Large #).

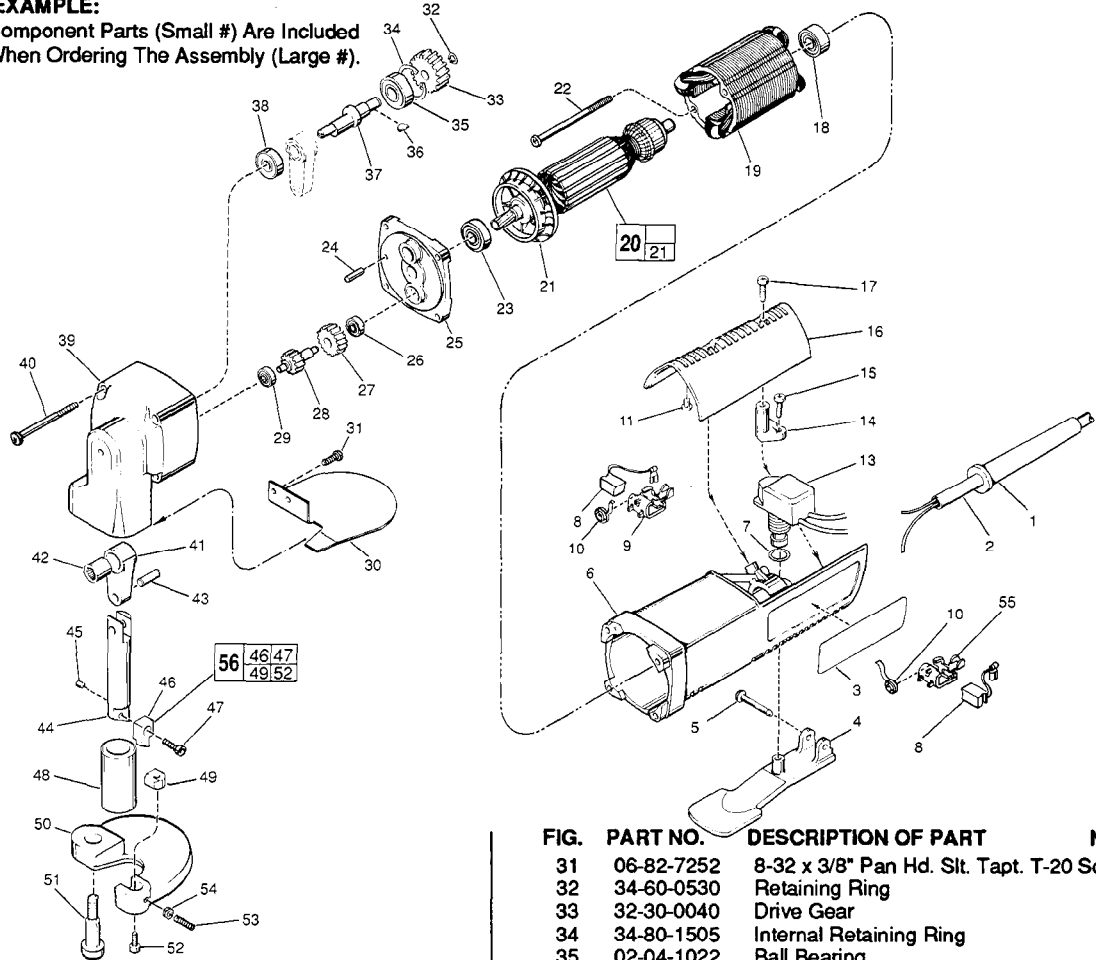

FIG.	PART NO.	DESCRIPTION OF PART	NO. REQ.
1	44-76-0110	Cord Protector	(1)
2	22-64-0215	Cord Set	(1)
★ 3	12-20-0540	Service Nameplate Kit	(1)
4	31-92-0225	Trigger Paddle	(1)
5	06-72-0810	Tapered Rivet	(1)
6	31-50-0310	Motor Housing	(1)
7	34-40-4015	O-Ring	(1)
8	22-18-0710	Carbon Brush Assembly	(2)
9	22-20-0692	Right Brush Holder	(1)
10	23-52-0240	Brush Spring	(2)
11	42-38-0181	Rubber Bumper	(2)
13	23-66-2170	Switch	(1)
14	31-17-0120	Cord Clamp	(1)
15	06-82-7270	8-16 x 5/8" Plastite T-20 Screw	(2)
★ 16	31-15-0290	Cover	(1)
17	06-82-7270	8-16 x 5/8" Plastite T-20 Screw	(2)
18	02-04-0850	Ball Bearing	(1)
19	18-07-0075	120 V. Field	(1)
20	16-07-0070	120 V. Armature	(1)
21	22-84-0680	Fan	(1)
22	06-82-7382	8-16 x 1-5/8" Tapitite T-20 Screw	(2)
23	02-08-0375	Ball Bearing	(1)
24	06-65-0825	1/8 x 1/2 Groove Pin No. 5	(1)
25	28-28-1670	Diaphragm	(1)
26	02-08-0200	Ball Bearing	(1)
27	32-40-1910	Intermediate Gear	(1)
28	36-66-4345	Intermediate Pinion Shaft	(1)
29	02-08-0200	Ball Bearing	(1)
30	43-54-0520	Guard	(1)

FIG.	PART NO.	DESCRIPTION OF PART	NO. REQ.
31	06-82-7252	8-32 x 3/8" Pan Hd. Slit. Tapt. T-20 Screw	(2)
32	34-60-0530	Retaining Ring	(1)
33	32-30-0040	Drive Gear	(1)
34	34-80-1505	Internal Retaining Ring	(1)
35	02-04-1022	Ball Bearing	(1)
36	06-42-0800	Woodruff Key	(1)
37	43-16-0180	Eccentric Shaft	(1)
38	02-04-0710	Ball Bearing	(1)
39	28-14-1575	Gear Case	(1)
40	06-82-7410	8-16 x 1-7/8" Plastite T-20 Screw	(4)
41	44-94-0210	Connecting Rod	(1)
42	02-50-2501	Needle Bearing	(1)
43	06-65-1310	Dowel Pin	(1)
44	38-50-5420	Spindle	(1)
45	44-46-0200	Felt Oiler	(1)
46	—	Top Shear Blade	(1)
47	06-75-2055	8-32 x 1/2" Lg. Skt. Hd. Screw	(1)
48	42-40-0395	Spindle Bushing	(1)
49	—	Bottom Shear Blade	(1)
50	30-99-0080	Yoke	(1)
51	45-04-0680	Shoulder Screw	(1)
52	06-75-2000	8-32 x 3/8" Skt. Hd. Screw	(1)
53	06-83-1900	8-32 x 1/2" Skt. Hd. Set Screw	(1)
54	06-55-0825	8-32 Hex Nut	(1)
55	22-20-0691	Left Brush Holder	(1)
56	48-44-0122	Shear Blade Kit	(1)
	49-11-0080	Feeler Gauge	(1)
	49-96-0040	5/64" Socket Wrench	(1)
	49-96-0065	9/64" Socket Wrench	(1)

**FIG. LUBRICATION**

- 39 3/4 Oz. Type "G" Grease, No. 49-08-4140
- 44/48 Coat Spindle with type "G" Grease before assembly with spindle bushing.

**MILWAUKEE ELECTRIC TOOL CORPORATION**  
13135 W. LISBON RD., BROOKFIELD, WI 53005