

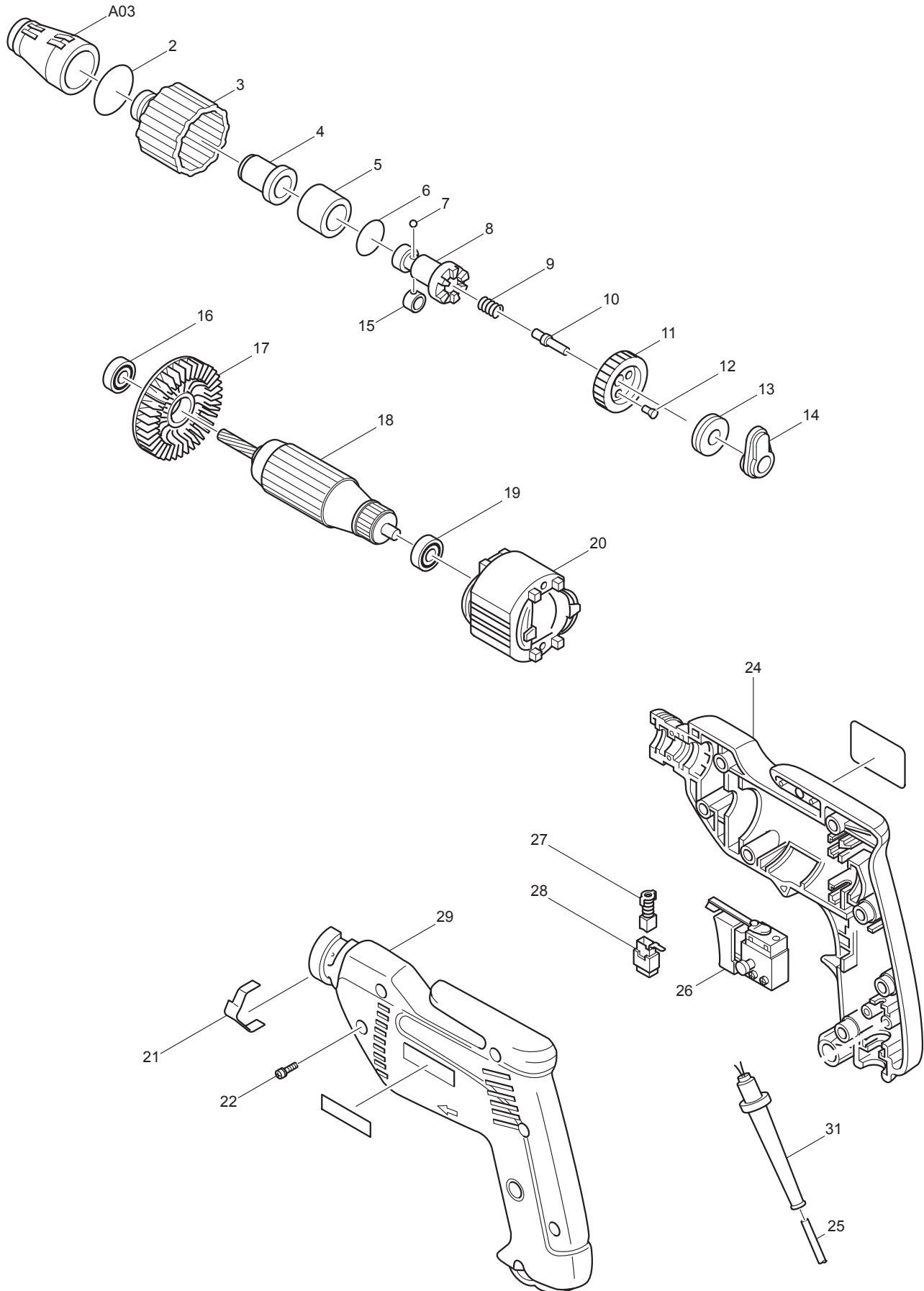

02 - 2013

6821

# DRYWALL SCREWDRIVER V.S.



<b>Item No.</b>	<b>Type</b>	<b>Sub</b>	<b>Part No.</b>	<b>Description (* see Service changes on the bottom)</b>	<b>Qty</b>	<b>Unit</b>
2			213373-4	O RING 22	1	PC.
3			415570-0	LOCK RING	1	PC.
4			421519-0	DUST RING	1	PC.
5			214154-9	PLANE BEARING 14	1	PC.
6			421392-8	RING 20	1	PC.
7			216001-0	STEEL BALL 3.5	1	PC.
8			223107-7	SPINDLE	1	PC.
9			233126-5	COMPRESSION SPRING 6	1	PC.
10			256699-1	PIN 8	1	PC.
11			226444-8	HELICAL GEAR 46	1	PC.
12			256467-2	SHOULDER PIN 4 (OLD# 256439-7 - N/L/A)	3	PC.
13			212047-4	THRUST NEEDLE BEARING 821	1	PC.
14			152531-6	BEARING BOX COMPLETE	1	PC.
15			232050-9	LEAF SPRING	1	PC.
16			211031-6	BALL BEARING 608LLB	1	PC.
17			241881-5	FAN 52	1	PC.
18			517151-7	ARMATURE ASS'Y 115V	1	PC.
		INC.		INC. 16,17,19		
19			211028-5	BALL BEARING 627LB	1	PC.
20			633321-1	FIELD 115V (WITH CLAMP # 687059-0)	1	PC.
21			232147-4	LEAF SPRING	1	PC.
22			911138-5	PAN HEAD SCREW M4X20	9	PC.
24			182856-4	* HOUSING SET	1	SET
		INC.	931102-0	HEX. NUT M4	9	PC.
		INC.		Item No. 29		
25			660066-8	CORD COM.W/PLUG2P-18-1.83 SQ	1	PC.
26			651986-7	* SWITCH TG803TLB-1	1	PC.
27	1		191927-6	CARBON BRUSH CB-407 2PC/SET (W/O ORIGIN)	1	SET
	2		195007-0	CARBON BRUSH CB-407 2PC/SET (W/ ORIGIN)	1	PC.
28	1		643923-5	BRUSH HOLDER	2	PC.
	2		643936-6	BRUSH HOLDER	2	PC.
29			182856-4	* HOUSING SET	1	SET
		INC.	931102-0	HEX. NUT M4	9	PC.
		INC.		Item No. 24		
100			654002-4	EYE TERMINAL 1.25-M4 (OLD)	2	PC.
<b><u>ACCESSORIES</u></b>						
A01			784807-9	MAGNETIC CONNECT BIT 6.35-60	1	PC.
A02			784211-2	PHILLIPS INSERT BIT P-2 (2-25)	1	PC.
			784212-0	PHILLIPS INSERT BIT P-1 (1-25)	1	PC.
			784213-8	PHILLIPS INSERT BIT P-3 (3-25)	1	PC.
A03			152483-1	LOCATOR COMPLETE 1/4"	1	PC.

**SERVICE CHANGES**

**1. Changes on Switch and Housing**

<b>Item No.</b>	<b>Description</b>	<b>Type 1</b>	<b>Type 2</b>	<b>Type 3</b>
24	Housing (R)	A415571-8 (N/L/A)	182856-4 (Set)	
29	Housing (L)	A415572-6 (N/L/A)		
26	Switch	651935-4 (N/L/A)	651987-5 (N/L/A)	651986-7

Above parts are completely interchangeable as a set.