



# SERVICE PARTS LIST

**BULLETIN NO.**  
**54-42-0356**

SPECIFY CATALOG NO. AND SERIAL NO. WHEN ORDERING PARTS		REVISED BULLETIN 54-42-0355	DATE Apr. '93
<b>ADJUSTABLE TORQUE SCREWDRIVER</b>		WIRING INSTRUCTION <b>58-01-0021</b>	
CATALOG NO. 6783-1	STARTING SERIAL NO. 471-67430		

**EXAMPLE:**  

00	0
----	---

 Component Parts (Small #) Are Included  
 When Ordering The Assembly (Large #).

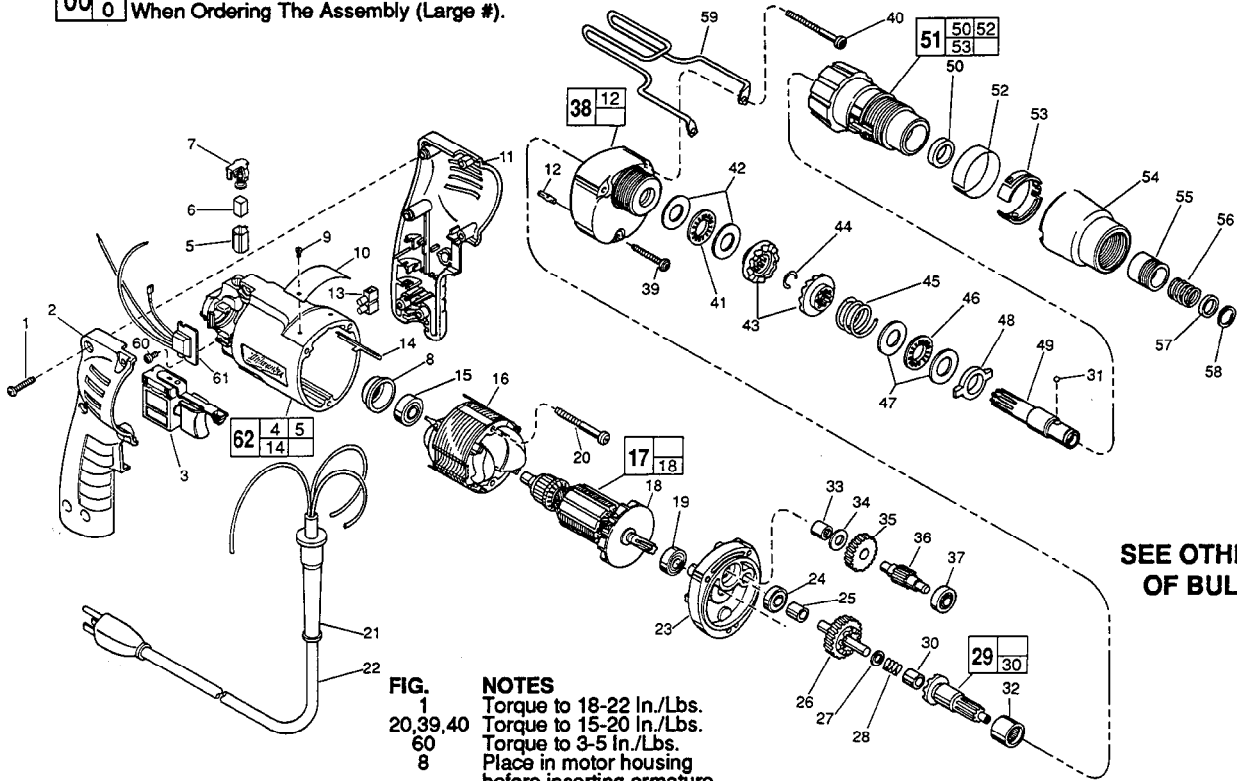

**SEE OTHER SIDE  
OF BULLETIN**

**FIG. NOTES**  
 1 Torque to 18-22 In./Lbs.  
 20,39,40 Torque to 15-20 In./Lbs.  
 60 Torque to 3-5 In./Lbs.  
 8 Place in motor housing before inserting armature.  
 30,33 Press only on end with manufacturer ID.  
 33 Press flush to casting surface.  
 30 Press 11/64" from clutch face.  
 15, 19,24 Seal towards armature.

FIG.	PART NO.	DESCRIPTION OF PART	NO. REQ.
★ 1	06-82-7284	8-16x 3/4" Pan Hd. Slit. Plast. T-20	(6)
★ 2	31-44-1705	Right Handle Half	(1)
★ 3	23-66-1655	Speed Control Switch	(1)
★ 4	23-94-6225	Ground Wire Assembly (Not Shown)	(1)
★ 5	22-20-0790	Brush Tube	(2)
★ 6	22-16-0275	Carbon Brush	(2)
★ 7	23-52-1560	Brush Spring Assembly	(2)
★ 8	22-72-0100	Bearing Cup	(1)
★ 9	06-85-0200	Nameplate Screw	(2)
★ 10	12-99-0850	Service Nameplate	(1)
★ 11	31-44-1700	Left Handle Half	(1)
★ 12	06-65-0825	1/8 x 1/2 Groove Pin No. 5	(1)
★ 13	22-56-0456	Terminal Block	(1)
★ 14	44-60-0530	Ground Pin	(1)
★ 15	02-04-0645	Ball Bearing	(1)
★ 16	18-11-0150	120 V. Field	(1)
★ 17	16-10-0380	120 V. Armature	(1)
★ 18	22-84-0830	Fan Assembly	(1)
★ 19	02-04-0848	Ball Bearing	(1)
★ 20	06-82-7393	7-18x2" Pan Hd. Slit. Plastite T-20	(2)
★ 21	44-76-0210	Cord Protector	(1)
★ 22	22-64-3180	Cord Set	(1)
★ 23	28-28-1960	Diaphragm	(1)
★ 24	02-04-0645	Ball Bearing	(1)
★ 25	45-36-1280	Spacer	(1)
★ 26	32-10-4045	Clutch Gear Assembly	(1)
★ 27	45-88-0712	Thrust Washer	(1)
★ 28	40-50-6600	Separator Spring	(1)
★ 29	14-73-0250	Clutch Shaft Assembly	(1)
★ 30	02-50-2400	Needle Bearing	(1)
★ 31	02-02-0130	Steel Ball	(1)
★ 32	02-50-4225	Needle Roller Bearing	(1)
★ 33	02-50-2410	Needle Bearing	(1)
★ 34	45-88-7990	Thrust Washer	(1)
★ 35	32-40-1612	Intermediate Gear	(1)
★ 36	36-66-4101	Intermediate Pinion Shaft	(1)
★ 37	02-04-0640	Ball Bearing	(1)
★ 38	14-30-0600	Gear Case Assembly	(1)

FIG.	PART NO.	DESCRIPTION OF PART	NO. REQ.
★ 39	06-82-7344	7-18x1-1/2" Pan Hd. Slit. Plast. T-20	(1)
★ 40	06-82-7440	7-18x 2-1/2" Pan Hd. Slit. Plast. T-20	(2)
★ 41	02-80-1210	Thrust Bearing	(1)
★ 42	45-88-0510	Thrust Bearing Washer	(2)
★ 43	42-70-5016	Drive Clutch	(2)
★ 44	34-60-0545	Retaining Ring	(1)
★ 45	40-50-8000	Clutch Spring	(1)
★ 46	02-80-6020	Thrust Bearing	(1)
★ 47	45-88-7150	Thrust Bearing Washer	(2)
★ 48	44-90-4280	Adjustment Ring	(1)
★ 49	42-66-0676	Chuck Shaft	(1)
★ 50	45-06-0106	Oil Seal	(1)
★ 51	14-08-0190	Clutch Housing Assembly	(1)
★ 52	10-79-3100	Torque Setting Label	(1)
★ 53	42-16-0140	Adjustment Band	(1)
★ 54	42-76-0460	Adjustment Collar	(1)
★ 55	42-76-0390	Locking Collar	(1)
★ 56	40-50-8005	Compression Spring	(1)
★ 57	45-36-1300	Spacer	(1)
★ 58	34-60-2390	Retaining Ring	(1)
★ 59	42-70-5080	Belt Clip	(1)
★ 60	06-82-7212	4-20 x 1/4" Pan Hd. Slit. Plastite T-10	(1)
★ 61	14-20-0405	Remote Electronic Assembly	(1)
★ 62	14-38-0550	Motor Housing Assembly	(1)
	49-66-3016	5/16" Hex Socket	(1)

**FIG. LUBRICATION**  
 38 1-1/2 Oz. Type "E" Grease, No. 49-08-4122.  
 43 1/16 Oz. Type "F" Grease, No. 49-08-4160 On Clutch Faces.  
 41,46,50 Apply Small Amount Of "F" Grease, No. 49-08-4160.  
 48 Apply Small Amount Of "F" Grease, No. 49-08-4160 On Tabs.

**MILWAUKEE ELECTRIC TOOL CORPORATION**  
 13135 W. LISBON RD., BROOKFIELD, WI 53005



**PARTS LIST IN ORDER OF ASSEMBLY  
ADJUSTABLE TORQUE SCREWDRIVER  
CAT. NO. 6583-1 AND 6783-1**

Clutch gear and other gears identical to #6543-1 and 6798-1 positive drive models.

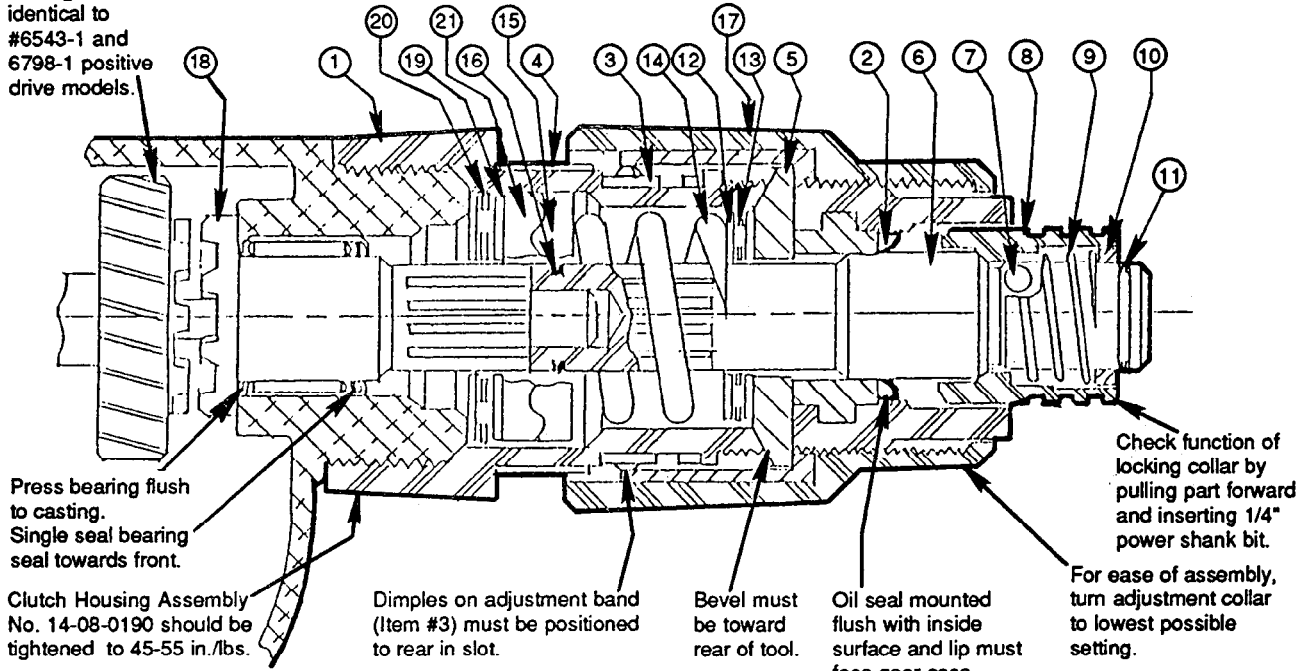

**LUBRICATION**

Apply 1/16 oz. Type "F" Grease on clutch faces of drive clutch (#15 & #21). Apply small amount of Type "F" Grease on trust bearings (#13 & #20, oil seal lip #2 and tabs of adjustment ring #5).

Drive clutches must slide back and forth freely on shaft splines. Defective splines that stick will not function properly.

	ITEM NO.	PART NO.	DESCRIPTION	
Clutch Housing Assembly No. 14-08-0190	1	43-76-0550	Clutch Housing ( Includes Bushing No. 42-40-0920 )	Clutch Sub-Assembly
	2	45-06-0106	Oil Seal	
	3	42-16-0140	Adjustment Band	
	4	10-79-3100	Torque Setting Label	
	5	44-90-4280	Adjustment Ring	
Sub-Assembly	6	42-66-0676	Chuck Shaft	
	7	02-02-0130	Steel Ball	
	8	42-76-0390	Locking Collar	
	9	40-50-8005	Spring	
	10	45-36-1300	Spacer	
	11	34-60-2390	Retaining Ring	
	12	45-88-7150	Thrust Washers ( 2 each ) ( Place on each side of Item # 13 )	
	13	02-80-6020	Thrust Bearing	
	14	40-50-8000	Clutch Spring	
	15	42-70-5016	Drive Clutch	
	16	34-60-0545	Retaining Ring	
17	42-76-0460	Adjustment Collar ( Includes Insert No. 43-84-0740 )	Not In Order Of Assembly	
18	14-73-0250	Clutch Shaft Assembly ( Includes Clutch Shaft No. 36-14-0661 and Needle Bearing No. 02-50-2400 )		
19	45-88-0510	Thrust Bearing Washers ( 2 each ) ( Place on each side of Item # 20 )		
20	02-80-1210	Thrust Bearing		
21	42-70-5016	Drive Clutch		