



SERVICE PARTS LIST

**BULLETIN NO.
54-42-0175**

SPECIFY CATALOG NO. AND SERIAL NO. WHEN ORDERING PARTS		REVISED BULLETIN	DATE
POSITIVE CLUTCH REV. SCREWDRIVER			May '94
CATALOG NO. 6760-1	STARTING SERIAL NO. 830A	WIRING INSTRUCTION 58-01-0032	

EXAMPLE:

00	0
----	---

 Component Parts (Small #) Are Included When Ordering The Assembly (Large #).

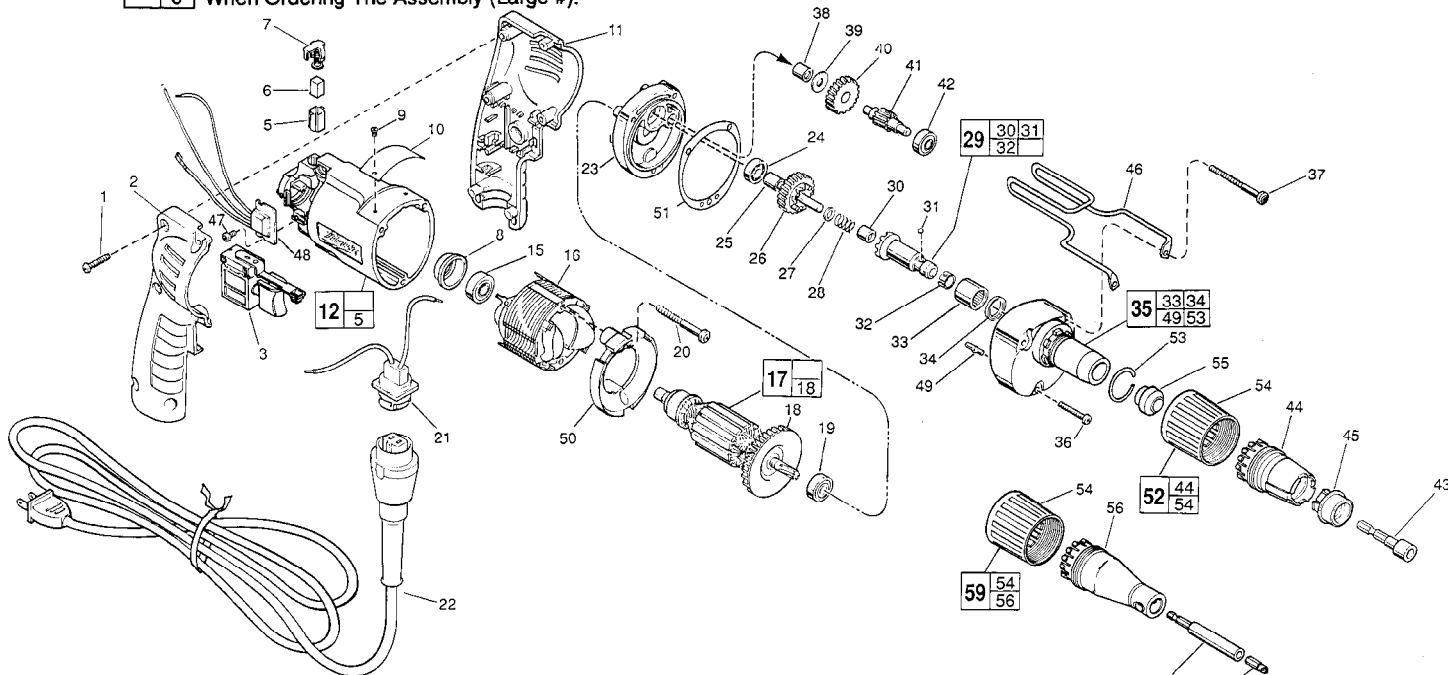

FIG.	PART NO.	DESCRIPTION OF PART	NO. REQ.
1	06-82-7284	8-16 x 3/4" Pan Hd. Slit. Plast. T-20	(6)
2	31-44-1845	Right Handle Half	(1)
3	23-66-2145	Speed Control Switch	(1)
5	22-20-0830	Brush Tube	(2)
6	22-16-0275	Carbon Brush	(2)
7	23-52-1570	Brush Spring Assembly	(2)
8	22-72-0100	Bearing Cup	(1)
9	06-85-0200	Nameplate Screw	(2)
10	12-99-0860	Service Nameplate	(1)
11	31-44-1840	Left Handle Half	(1)
12	14-38-0590	Motor Housing Assembly	(1)
15	02-04-0645	Ball Bearing	(1)
16	18-11-0150	120 Volt Field	(1)
17	16-10-0690	120 Volt Armature	(1)
18	22-84-0880	Fan Assembly	(1)
19	02-04-0851	Ball Bearing	(1)
20	06-82-7203	7-18 x 2-1/8" Pan Hd. Slit. Plast. T-20	(2)
21	22-56-0665	Blade Housing Assembly	(1)
22	48-76-5010	Cord Set	(1)
23	28-28-1961	Diaphragm	(1)
24	02-04-0645	Ball Bearing	(1)
25	45-36-1280	Spacer	(1)
26	32-10-4045	Clutch Gear Assembly	(1)
27	45-88-0712	Thrust Washer	(1)
28	40-50-6600	Separator Spring	(1)
29	42-66-0775	Clutch Chuck Assembly	(1)
30	02-50-2400	Needle Bearing	(1)
31	02-02-0130	Steel Ball	(1)
32	40-50-0510	Bit Retaining Spring	(1)
33	02-50-4220	Needle Roller Bearing	(1)
34	45-06-0570	Oil Seal	(1)
35	14-30-0740	Gear Case Assembly	(1)
36	06-82-7344	7-18 x 1-1/2" Pan Hd. Slit. Plast. T-20	(1)
37	06-82-7464	7-18 x 2-3/4" Pan Hd. Slit. Plast. T-20	(2)
38	02-50-2410	Needle Bearing	(1)
39	45-88-7990	Thrust Washer	(1)
40	32-40-1612	Intermediate Gear	(1)
41	36-66-4101	Intermediate Pinion Shaft	(1)
42	02-04-0645	Ball Bearing	(1)

FIG.	PART NO.	DESCRIPTION OF PART	NO. REQ.
43	49-66-3016	5/16" Hex Socket	(1)
44	31-51-0100	Locator	(1)
45	49-26-0400	1/4" Tek Guide	(1)
	49-26-0405	5/16" Tek Guide	(1)
	49-26-0410	3/8" Tek Guide	(1)
46	42-70-5080	Belt Clip	(1)
47	06-82-7212	4-20 x 1/4" Pan Hd. Slit. Plast. T-10	(1)
48	14-20-0750	Remote Electronic Assembly	(1)
49	06-65-0825	1/8 x 1/2 Groove Pin 5	(1)
50	42-14-0380	Baffle	(1)
51	43-44-0925	Gasket	(1)
52	49-26-1080	Locator Assembly	(1)
53	44-90-0401	Locator Ring	(1)
54	31-58-0510	Locator Sleeve	(1)
55	30-37-0045	Guide	(1)
56	31-51-0090	Locator	(1)
57	48-32-3065	Magnetic Bit Holder	(1)
58	48-32-1050	#2 Insert Bit	(1)
59	49-26-1035	Locator Assembly	(1)

FIG. LUBRICATION
35 1-1/2 Oz. Type "E" Grease, No. 49-08-4122.
Place Near Intermediate Shaft Ball Bearing In Gear Case.

FIG. NOTES
1 Torque to 18-22 In./Lbs.
20,36,37 Torque to 15-20 In./Lbs.
47 Torque to 3-5 In./Lbs.
8 Place in motor housing before inserting armature.
30,33,38 Press only on end with manufacturer ID.
33 Press 13/16" from cast surface.
38 Press flush to casting surface.
34 Spring side towards rear of gear case.
15,42,24 Seal towards armature.
30 Press 11/64" from clutch face.

MILWAUKEE ELECTRIC TOOL CORPORATION
13135 W. LISBON RD., BROOKFIELD, WI 53005