



# SERVICE PARTS LIST

**BULLETIN NO.**  
54-42-0080

SPECIFY CATALOG NO. AND SERIAL NO. WHEN ORDERING PARTS		REVISED BULLETIN	DATE
<b>MAGNUM SCREW-SHOOTER</b>			May '85
<b>CATALOG NO. 6749-1</b>	<b>STARTING SERIAL NO. 694-1001</b>	<b>WIRING INSTRUCTION 58-01-0072</b>	
<b>CAT. NO. 6749-6</b>	<b>START SER. NO. 694-1001</b>	<b>BILINGUAL LABEL 10-98-6405</b>	

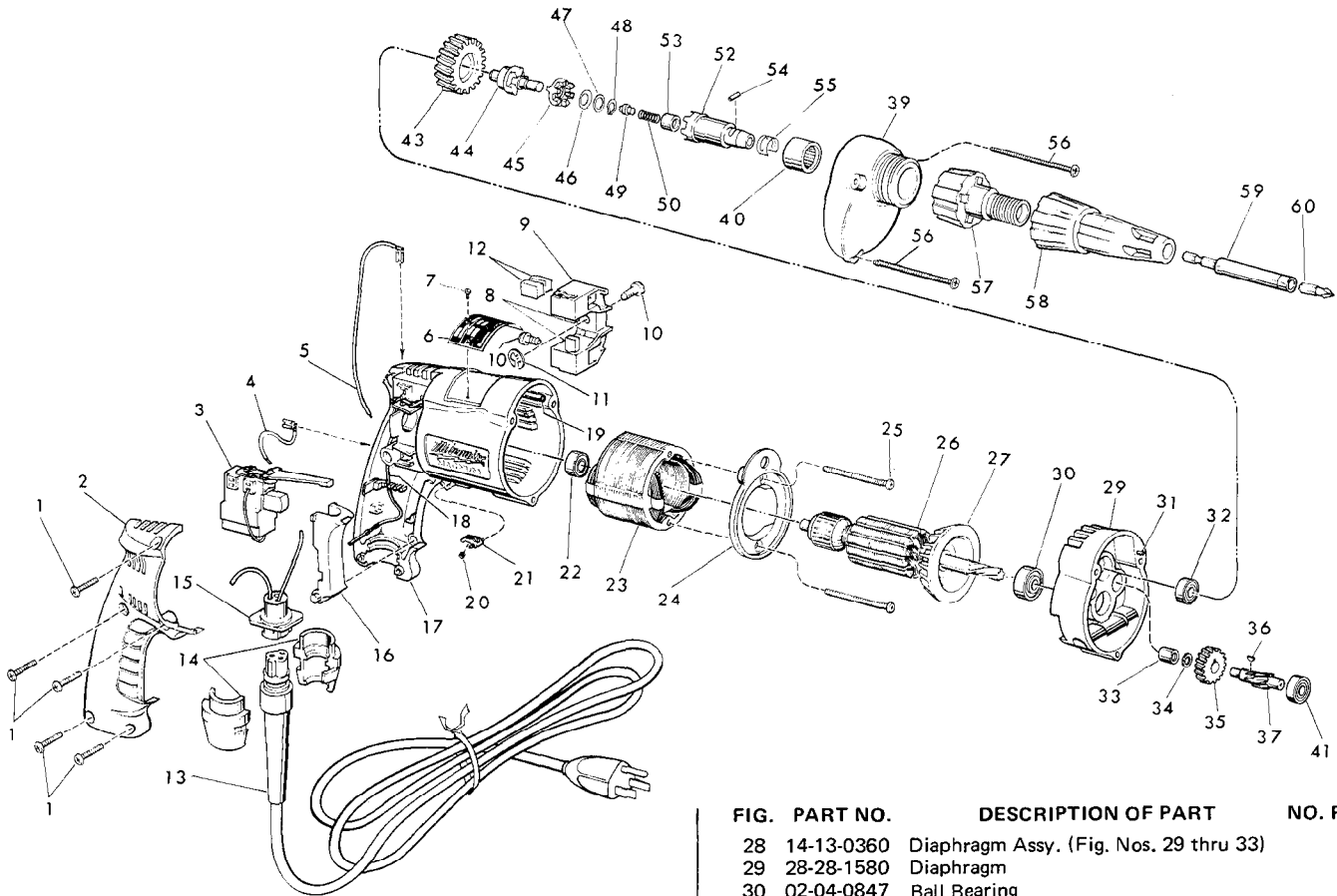

FIG.	PART NO.	DESCRIPTION OF PART	NO. REQ.
1	06-95-0185	7-18 x 11/16 Plastite Screw	(5)
2	31-15-0101	Handle Cover	(1)
3	23-66-1350	Trigger Speed Control Reversing Switch	(1)
4	23-94-9635	2-1/4 Lead Assembly	(1)
5	23-94-9640	7" Lead Assembly	(1)
6	12-99-0081	Nameplate Blank	(1)
7	06-85-0200	Nameplate Screw	(2)
8	22-16-0275	Carbon Brush	(2)
9	22-22-0350	Brush Holder Assy. (Includes Fig. Nos. 10 thru 12)	(1)
10	31-75-0011	Brush Holder Screw	(2)
11	34-60-0500	1/4" Ext. Retaining Ring	(1)
12	22-16-0275	Carbon Brush (Spare)	(2)
13	48-76-3008	Cord Set (Includes Fig. No. 14)	(1)
14	44-40-0440	Cord Nut	(2)
15	22-56-0302	Pin Housing Assembly	(1)
16	45-72-0080	Trigger	(1)
17	14-38-0355	Motor Housing Assy. (Includes Fig. Nos. 18 & 19)	(1)
18	23-94-9686	Ground Wire Assembly	(1)
19	44-60-0570	Grounding Pin	(1)
20	40-50-0085	Lock Button Spring	(1)
21	42-42-0150	Lock Button	(1)
22	02-04-0645	Ball Bearing	(1)
23	18-10-0045	120 Volt Field	(1)
24	31-05-0065	Baffle	(1)
25	06-95-0140	No. 7x1-7/8" Pan Hd. Screw	(2)
26	16-10-0500	120 V. Armature Assy. (Incl. Fig. No. 27)	(1)
27	22-84-0650	Fan Assembly	(1)

FIG.	PART NO.	DESCRIPTION OF PART	NO. REQ.
28	14-13-0360	Diaphragm Assy. (Fig. Nos. 29 thru 33)	(1)
29	28-28-1580	Diaphragm	(1)
30	02-04-0847	Ball Bearing	(1)
31	06-65-0825	1/8 x 1/2 Groove Pin No. 5	(1)
32	02-04-0645	Ball Bearing	(1)
33	02-50-1620	Needle Bearing	(1)
34	45-88-7721	Heat Treated Washer	(1)
35	32-40-1815	Intermediate Gear	(1)
36	06-42-0400	Woodruff Key	(1)
37	36-66-4250	Intermediate Pinion	(1)
38	14-30-0340	Gear Case Assy. (Incl. Fig. Nos. 39 thru 41)	(1)
39	28-14-1450	Gear Case	(1)
40	02-50-4050	Needle Bearing	(1)
41	02-04-0640	Ball Bearing	(1)
42	32-10-4035	Clutch Gear Assy. (Fig. Nos. 43 thru 48)	(1)
43	32-75-2920	Spindle Gear	(1)
44	36-14-0680	Gear Shaft	(1)
45	42-70-5030	Drive Clutch	(1)
46	45-88-0705	Spring Washer	(1)
47	45-88-0550	Flat Washer	(1)
48	34-60-0510	External Retaining Ring	(1)
49	44-60-0500	Thrust Pin	(1)
50	40-50-0080	Separator Spring	(1)
51	14-73-0120	Chuck Shaft Assy. (Incl. Fig. Nos. 52 thru 55)	(1)
52	42-66-6770	Chuck Shaft	(1)
53	02-50-1610	Needle Bearing	(1)
54	02-55-0150	Loose Roller Bearing	(1)
55	40-50-1450	Bit Retaining Spring	(1)
56	06-95-0150	No. 7x2-3/16" Pan Hd. Screw	(3)
57	48-32-2500	Bit Housing	(1)
58	49-26-1026	Locator Assembly	(1)
59	48-32-3025	Magnet Bit Holder 1/4 Hex	(1)
60	48-32-1050	Insert Bit No. 2 Phil. 1/4 H	(1)
61	10-98-5986	Warning Label (Not Shown) Omit For Canadian Tools	(1)

**MILWAUKEE ELECTRIC TOOL CORPORATION**  
13135 W. LISBON RD., BROOKFIELD, WIS. 53005