



# SERVICE PARTS LIST

**BULLETIN NO.**  
**54-42-0410**

SPECIFY CATALOG NO. AND SERIAL NO. WHEN ORDERING PARTS		REVISED BULLETIN	DATE
<b>ADJUSTABLE TORQUE SCREWDRIVER</b>		54-42-0409	Nov. '94
CATALOG NO. <b>6583-1</b>	STARTING SERIAL NO. <b>470D</b>	WIRING INSTRUCTION <b>58-01-0032</b>	

**EXAMPLE:**

00 0 Component Parts (Small #) Are Included  
When Ordering The Assembly (Large #).

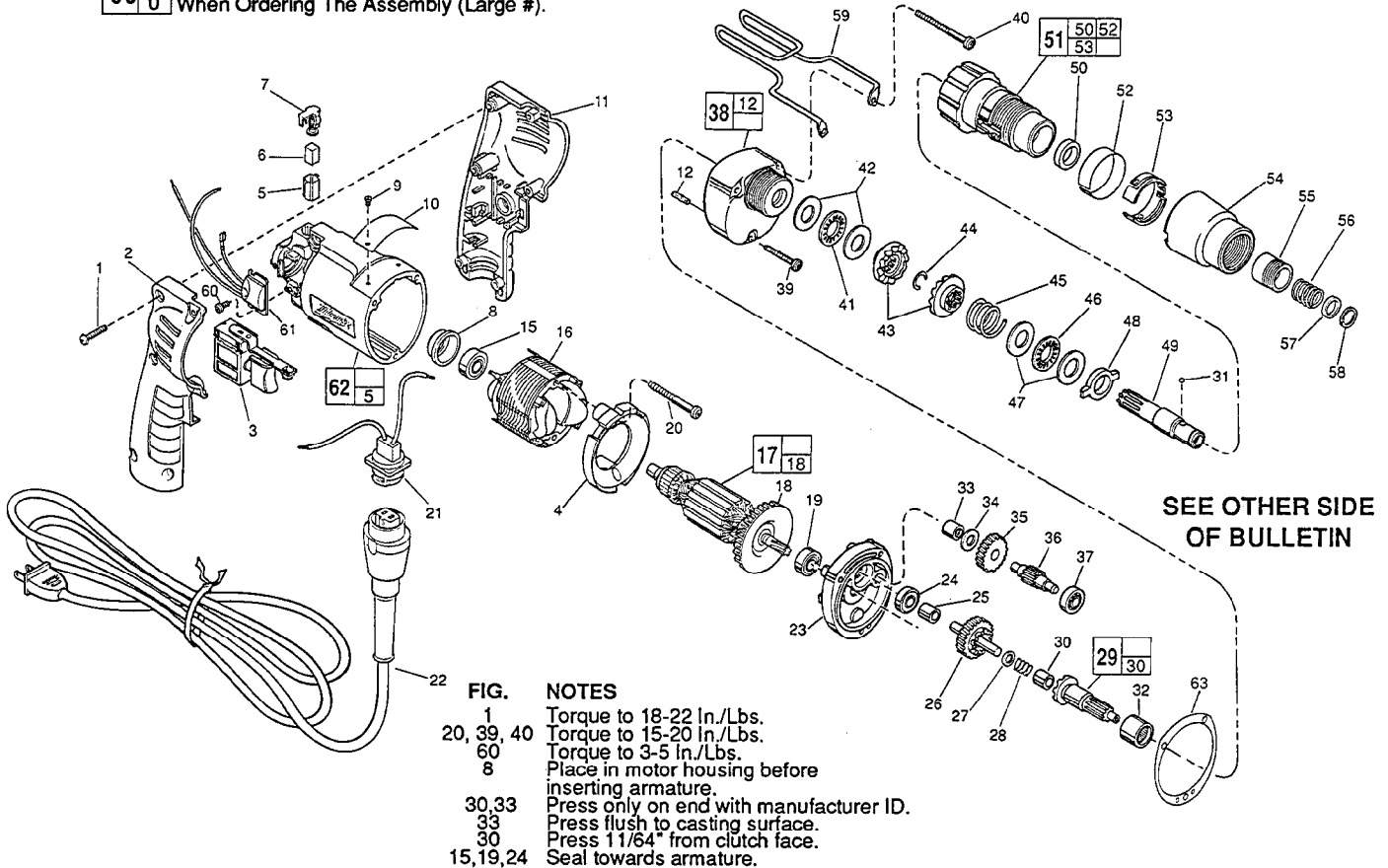

SEE OTHER SIDE  
OF BULLETIN

- FIG. NOTES**
- 1 Torque to 18-22 In./Lbs.
  - 20, 39, 40 Torque to 15-20 In./Lbs.
  - 60 Torque to 3-5 In./Lbs.
  - 8 Place in motor housing before inserting armature.
  - 30, 33 Press only on end with manufacturer ID.
  - 33 Press flush to casting surface.
  - 30 Press 11/64" from clutch face.
  - 15, 19, 24 Seal towards armature.

FIG.	PART NO.	DESCRIPTION OF PART	NO.	REQ.	FIG.	PART NO.	DESCRIPTION OF PART	NO.	REQ.
1	06-82-7284	8-16 x 3/4" Pan Hd. Slit. Plast. T-20	(6)		40	06-82-7464	7-18 x 2-3/4" Pan Hd. Slit. Plast. T-20	(2)	
2	31-44-1845	Right Handle Half	(1)		41	02-80-1210	Thrust Bearing	(1)	
3	23-66-2145	Speed Control Switch	(1)		42	45-88-0510	Thrust Bearing Washer	(2)	
4	42-14-0380	Baffle	(1)		43	42-70-5016	Drive Clutch	(2)	
5	22-20-0830	Brush Tube	(1)		44	34-60-0545	Retaining Ring	(1)	
6	22-16-0275	Carbon Brush	(2)		45	40-50-8000	Clutch Spring	(1)	
7	23-52-1560	Brush Spring Assembly	(2)		46	02-80-6020	Thrust Bearing	(1)	
8	22-72-0100	Bearing Cup	(1)		47	45-88-7150	Thrust Bearing Washer	(2)	
★ 9	06-72-1720	Nameplate Rivet	(2)		48	44-90-4280	Adjustment Ring	(1)	
10	12-99-0860	Service Nameplate	(1)		49	42-66-0676	Chuck Shaft	(1)	
11	31-44-1840	Left Handle Half	(1)		50	45-06-0106	Oil Seal	(1)	
12	06-65-0825	1/8 x 1/2 Groove Pin No. 5	(1)		51	14-08-0190	Clutch Housing Assembly	(1)	
15	02-04-0645	Ball Bearing	(1)		52	10-79-3100	Torque Setting Label	(1)	
16	18-11-0150	120 V. Field	(1)		53	42-16-0140	Adjustment Band	(1)	
17	16-10-0680	120 V. Armature	(1)		54	42-76-0460	Adjustment Collar	(1)	
18	22-84-0880	Fan Assembly	(1)		55	42-76-0390	Locking Collar	(1)	
19	02-04-0851	Ball Bearing	(1)		56	40-50-8005	Compression Spring	(1)	
20	06-82-7203	7-18 x 2-1/8" Pan Hd. Slit. Plastite T-20	(2)		57	45-36-1300	Spacer	(1)	
21	22-56-0665	Blade Housing Assembly	(1)		58	34-60-2390	Retaining Ring	(1)	
22	48-76-5010	Cord Set	(1)		59	42-70-5080	Belt Clip	(1)	
23	28-28-1961	Diaphragm	(1)		60	06-82-7212	4-20 x 1/4" Pan Hd. Slit. Plastite T-10	(1)	
24	02-04-0645	Ball Bearing	(1)		61	14-20-0750	Remote Electronic Assembly	(1)	
25	45-36-1280	Spacer	(1)		★ 62	14-38-0591	Motor Housing Assembly	(1)	
26	32-10-4050	Clutch Gear Assembly	(1)		63	43-44-0925	Gasket	(1)	
27	45-88-0712	Thrust Washer	(1)						
28	40-50-6600	Separator Spring	(1)						
29	14-73-0250	Clutch Shaft Assembly	(1)						
30	02-50-2400	Needle Bearing	(1)						
31	02-02-0130	Steel Ball	(1)						
32	02-50-4225	Needle Roller Bearing	(1)						
33	02-50-2410	Needle Bearing	(1)						
34	45-88-7990	Thrust Washer	(1)						
35	32-40-1613	Intermediate Gear	(1)						
36	36-66-4096	Intermediate Pinion Shaft	(1)						
37	02-04-0640	Ball Bearing	(1)						
38	14-30-0600	Gear Case Assembly	(1)						
39	06-82-7344	7-18 x 1-1/2" Pan Hd. Slit. Plast. T-20	(1)						

**FIG. LUBRICATION**

- 38 1-1/2 Oz. Type "E" Grease, No. 49-08-4122.
- 43 1/16 Oz. Type "F" Grease, No. 49-08-4160 On Clutch Faces.
- 41, 46, 50 Apply Small Amount Of Type "F" Grease, No. 49-08-4160.
- 48 Apply Small Amount Of Type "F" Grease, No. 49-08-4160, On Tabs.

**MILWAUKEE ELECTRIC TOOL CORPORATION**  
13135 W. LISBON RD., BROOKFIELD, WI 53005



**PARTS LIST IN ORDER OF ASSEMBLY  
ADJUSTABLE TORQUE SCREWDRIVER  
CAT. NO. 6583-1 AND 6783-1**

Clutch gear and other gears identical to #6543-1 and 6798-1 positive drive models.

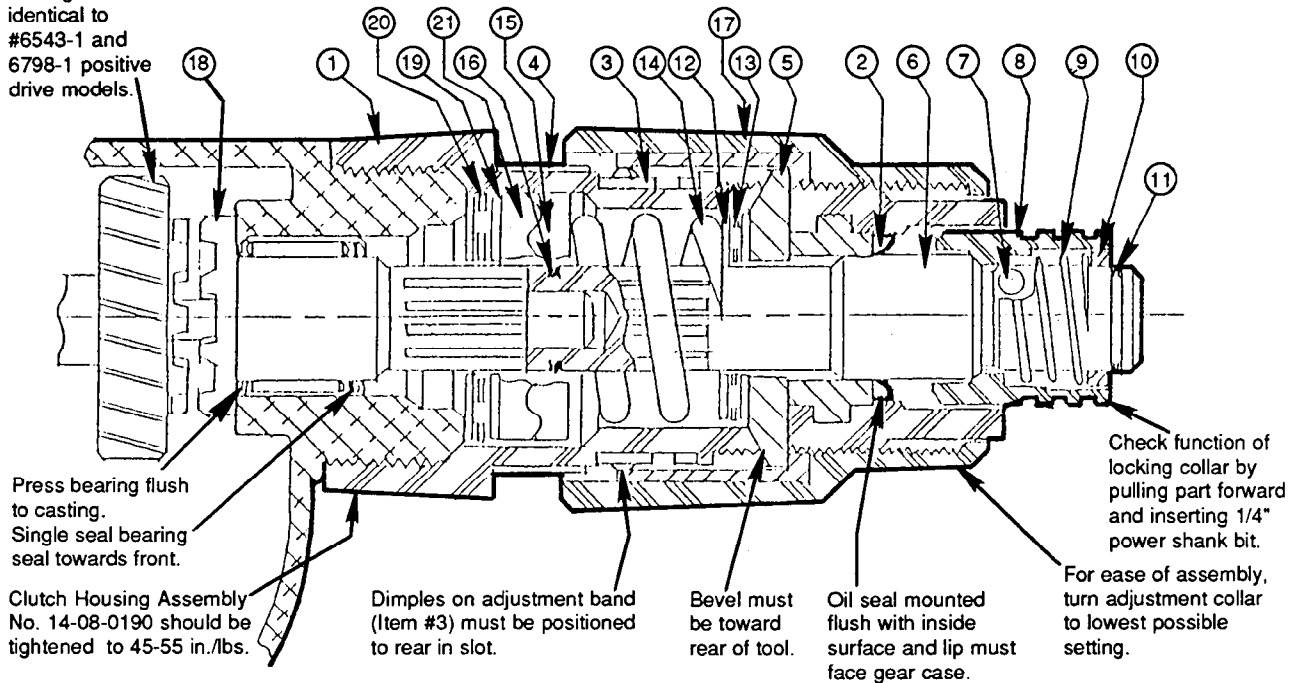

**LUBRICATION**

Apply 1/16 oz. Type "F" Grease on clutch faces of drive clutch (#15 & #21). Apply small amount of Type "F" Grease on trust bearings (#13 & #20, oil seal lip #2 and tabs of adjustment ring #5).

Drive clutches must slide back and forth freely on shaft splines. Defective splines that stick will not function properly.

	ITEM NO.	PART NO.	DESCRIPTION	
Clutch Housing Assembly No. 14-08-0190	1	43-76-0550	Clutch Housing ( Includes Bushing No. 42-40-0920 )	Clutch Sub-Assembly
	2	45-06-0106	Oil Seal	
	3	42-16-0140	Adjustment Band	
Sub-Assembly	4	10-79-3100	Torque Setting Label	
	5	44-90-4280	Adjustment Ring	
	6	42-66-0676	Chuck Shaft	
	7	02-02-0130	Steel Ball	
	8	42-76-0390	Locking Collar	
	9	40-50-8005	Spring	
	10	45-36-1300	Spacer	
	11	34-60-2390	Retaining Ring	
	12	45-88-7150	Thrust Washers ( 2 each ) ( Place on each side of Item # 13 )	
	13	02-80-6020	Thrust Bearing	
14	40-50-8000	Clutch Spring		
15	42-70-5016	Drive Clutch		
16	34-60-0545	Retaining Ring		
	17	42-76-0460	Adjustment Collar ( Includes Insert No. 43-84-0740 )	Not In Order Of Assembly
	18	14-73-0250	Clutch Shaft Assembly ( Includes Clutch Shaft No. 36-14-0661 and Needle Bearing No. 02-50-2400 )	
	19	45-88-0510	Thrust Bearing Washers ( 2 each ) ( Place on each side of Item # 20 )	
	20	02-80-1210	Thrust Bearing	
	21	42-70-5016	Drive Clutch	