



# SERVICE PARTS LIST

**BULLETIN NO.**  
54-42-0407

SPECIFY CATALOG NO. AND SERIAL NO. WHEN ORDERING PARTS		REVISED BULLETIN 54-42-0406	DATE May '93
<b>ADJUSTABLE TORQUE SCREWDRIVER</b>			
CATALOG NO. 6583-1	STARTING SERIAL NO. 470-70000 or 470A	WIRING INSTRUCTION 58-01-0023	

**EXAMPLE:**

**00** **0** Component Parts (Small #) Are Included  
When Ordering The Assembly (Large #).

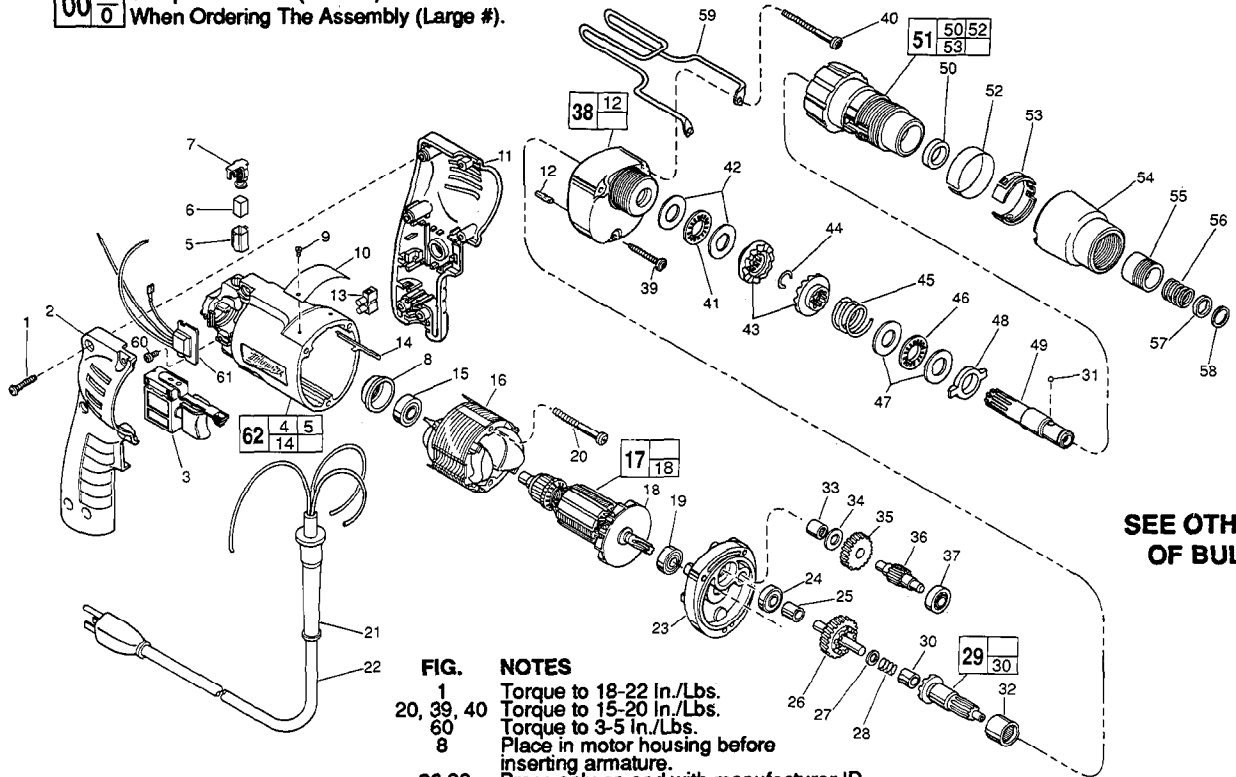

**SEE OTHER SIDE  
OF BULLETIN**

- FIG. NOTES**
- 1 Torque to 18-22 In./Lbs.
  - 20, 39, 40 Torque to 15-20 In./Lbs.
  - 60 Torque to 3-5 In./Lbs.
  - 8 Place in motor housing before inserting armature.
  - 30, 33 Press only on end with manufacturer ID.
  - 33 Press flush to casting surface.
  - 30 Press 11/64" from clutch face.
  - 15, 19, 24 Seal towards armature.

FIG.	PART NO.	DESCRIPTION OF PART	NO. REQ.
1	06-82-7284	8-16 x 3/4" Pan Hd. Slit. Plast. T-20	(6)
★ 2	31-44-1745	Right Handle Half	(1)
★ 3	23-66-2145	Speed Control Switch	(1)
4	23-94-6225	Ground Wire Assembly (Not Shown)	(1)
★ 5	22-20-0830	Brush Tube	(2)
6	22-16-0275	Carbon Brush	(2)
7	23-52-1560	Brush Spring Assembly	(2)
8	22-72-0100	Bearing Cup	(1)
9	06-85-0200	Nameplate Screw	(2)
10	12-99-0850	Service Nameplate	(1)
★ 11	31-44-1740	Left Handle Half	(1)
12	06-65-0825	1/8 x 1/2 Groove Pin No. 5	(1)
13	22-56-0456	Terminal Block	(1)
14	44-60-0530	Ground Pin	(1)
15	02-04-0645	Ball Bearing	(1)
16	18-11-0150	120 V. Field	(1)
17	16-10-0370	120 V. Armature	(1)
18	22-84-0830	Fan Assembly	(1)
19	02-04-0848	Ball Bearing	(1)
20	06-82-7393	7-18 x 2" Pan Hd. Slit. Plastite T-20	(2)
21	44-76-0210	Cord Protector	(1)
★ 22	22-64-1120	Cord Set	(1)
23	28-28-1960	Diaphragm	(1)
24	02-04-0645	Ball Bearing	(1)
25	45-36-1280	Spacer	(1)
26	32-10-4050	Clutch Gear Assembly	(1)
27	45-88-0712	Thrust Washer	(1)
28	40-50-6600	Separator Spring	(1)
29	14-73-0250	Clutch Shaft Assembly	(1)
30	02-50-2400	Needle Bearing	(1)
31	02-02-0130	Steel Ball	(1)
32	02-50-4225	Needle Roller Bearing	(1)
33	02-50-2410	Needle Bearing	(1)
34	45-88-7990	Thrust Washer	(1)
35	32-40-1613	Intermediate Gear	(1)
36	36-66-4096	Intermediate Pinion Shaft	(1)
37	02-04-0640	Ball Bearing	(1)
38	14-30-0600	Gear Case Assembly	(1)

FIG.	PART NO.	DESCRIPTION OF PART	NO. REQ.
39	06-82-7344	7-18 x 1-1/2" Pan Hd. Slit. Plast. T-20	(1)
★ 40	06-82-7464	7-18 x 2-3/4" Pan Hd. Slit. Plast. T-20	(2)
41	02-80-1210	Thrust Bearing	(1)
42	45-88-0510	Thrust Bearing Washer	(2)
43	42-70-5016	Drive Clutch	(2)
44	34-60-0545	Retaining Ring	(1)
45	40-50-8000	Clutch Spring	(1)
46	02-80-6020	Thrust Bearing	(1)
47	45-88-7150	Thrust Bearing Washer	(2)
48	44-90-4280	Adjustment Ring	(1)
49	42-66-0676	Chuck Shaft	(1)
50	45-06-0106	Oil Seal	(1)
51	14-08-0190	Clutch Housing Assembly	(1)
52	10-79-3100	Torque Setting Label	(1)
53	42-16-0140	Adjustment Band	(1)
54	42-76-0460	Adjustment Collar	(1)
55	42-76-0390	Locking Collar	(1)
56	40-50-8005	Compression Spring	(1)
57	45-36-1300	Spacer	(1)
58	34-60-2390	Retaining Ring	(1)
59	42-70-5080	Belt Clip	(1)
60	06-82-7212	4-20 x 1/4" Pan Hd. Slit. Plastite T-10	(1)
★ 61	14-20-0650	Remote Electronic Assembly	(1)
★ 62	14-38-0600	Motor Housing Assembly	(1)
	48-30-2600	Bit and Finder 1/4" Hex	(1)
	48-30-2650	Bit and Finder 1/4" Hex	(1)
	48-32-1050	Insert Bit 1/4" Hex	(1)
	48-32-3050	Bit Holder 1/4" Hex	(1)

**FIG. LUBRICATION**

- 38 1-1/2 Oz. Type "E" Grease, No. 49-08-4122.
- 43 1/16 Oz. Type "F" Grease, No. 49-08-4160 On Clutch Faces.
- 41, 46, 50 Apply Small Amount of Type "F" Grease, No. 49-08-4160.
- 48 Apply Small Amount of Type "F" Grease, No. 49-08-4160 On Tabs.

**MILWAUKEE ELECTRIC TOOL CORPORATION**  
13135 W. LISBON RD., BROOKFIELD, WI 53005



**PARTS LIST IN ORDER OF ASSEMBLY  
ADJUSTABLE TORQUE SCREWDRIVER  
CAT. NO. 6583-1 AND 6783-1**

Clutch gear and other gears identical to #6543-1 and 6798-1 positive drive models.

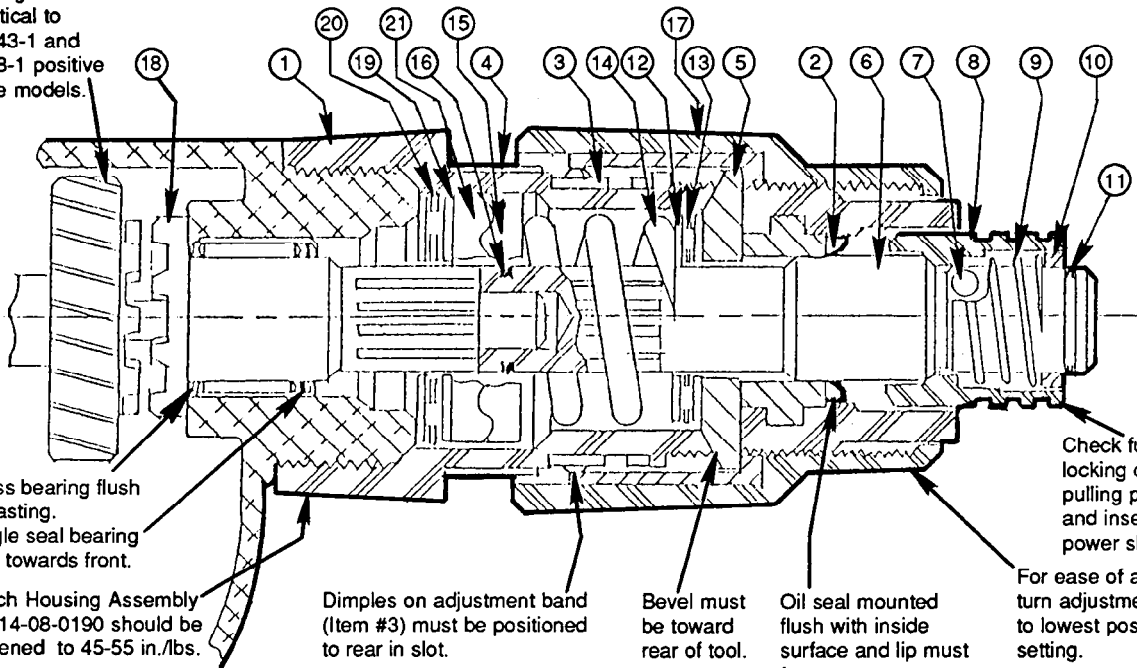

Press bearing flush to casting. Single seal bearing seal towards front.

Clutch Housing Assembly No. 14-08-0190 should be tightened to 45-55 in./lbs.

Dimples on adjustment band (Item #3) must be positioned to rear in slot.

Bevel must be toward rear of tool.

Oil seal mounted flush with inside surface and lip must face gear case.

Check function of locking collar by pulling part forward and inserting 1/4" power shank bit.

For ease of assembly, turn adjustment collar to lowest possible setting.

**LUBRICATION**

Apply 1/16 oz. Type "F" Grease on clutch faces of drive clutch (#15 & #21). Apply small amount of Type "F" Grease on trust bearings (#13 & #20, oil seal lip #2 and tabs of adjustment ring #5).

Drive clutches must slide back and forth freely on shaft splines. Defective splines that stick will not function properly.

ITEM NO.	PART NO.	DESCRIPTION	
Clutch Housing Assembly No. 14-08-0190	1	43-76-0550	Clutch Sub-Assembly
	2	45-06-0106	
	3	42-16-0140	
Sub-Assembly	4	10-79-3100	
	5	44-90-4280	
	6	42-66-0676	
	7	02-02-0130	
	8	42-76-0390	
	9	40-50-8005	
	10	45-36-1300	
	11	34-60-2390	
	12	45-88-7150	
	13	02-80-6020	
	14	40-50-8000	
15	42-70-5016		
16	34-60-0545		
17	42-76-0460	Adjustment Collar ( Includes Insert No. 43-84-0740 )	Not In Order Of Assembly
18	14-73-0250		
19	45-88-0510		
20	02-80-1210		
21	42-70-5016		