



SERVICE PARTS LIST

BULLETIN NO.
54-40-5153

SPECIFY CATALOG NO. AND SERIAL NO. WHEN ORDERING PARTS		REVISED BULLETIN	DATE
SUPER SAWZALL with QUIK-LOK BLADE CLAMP		54-40-5152	Sept. '97
CATALOG NO. 6537-22	STARTING SERIAL NUMBER 916D	WIRING INSTRUCTION 58-01-0781	

EXAMPLE:
Component Parts (Small #)
Are Included When Ordering
The Assembly (Large #).

00
0

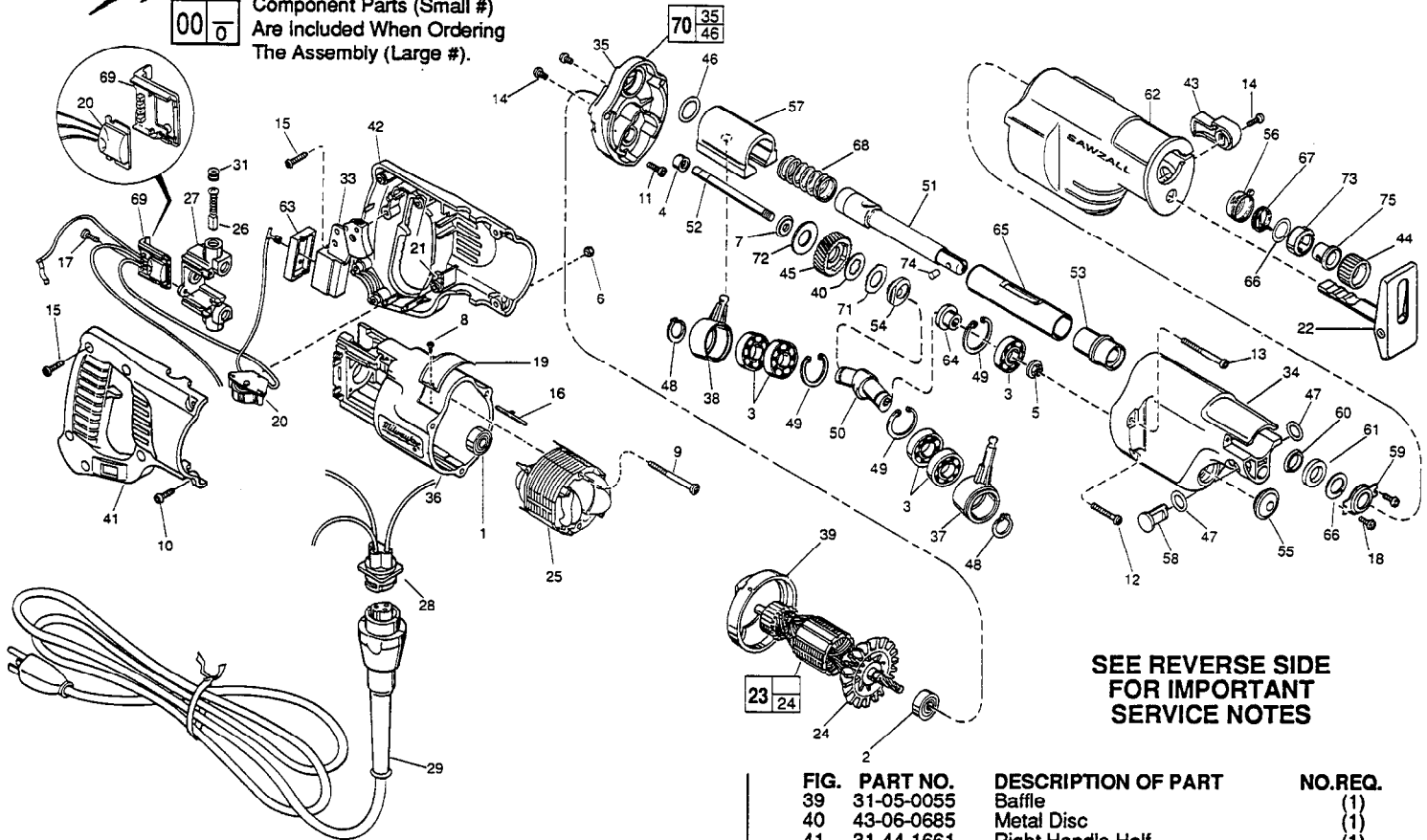

**SEE REVERSE SIDE
FOR IMPORTANT
SERVICE NOTES**

FIG.	PART NO.	DESCRIPTION OF PART	NO. REQ.
1	02-04-0845	Ball Bearing	(1)
2	02-04-0911	Ball Bearing	(1)
3	02-04-1510	Ball Bearing	(5)
4	02-50-2150	Needle Bearing	(1)
5	06-55-3790	Spinlock Hex Nut 5/16-24	(1)
6	06-55-0835	8-32 Hex Nut	(2)
7	43-78-0530	Rear Hub	(1)
8	06-72-1710	Nameplate Rivet	(2)
9	06-82-7410	8-16 x 1-7/8" Pan Hd. Slit. Plastite T-20	(2)
10	06-82-2390	8-32 x 1-1/4" Pan Hd. Slit. T-20	(2)
11	05-88-8307	Pan Hd. PT T-20	(1)
12	06-82-5390	8-32 x 1-1/4" Pan Hd. Slit. Tapt. T-20	(2)
13	05-88-8301	Pan Hd. PT T-20	(2)
14	06-82-7252	8-32 x 3/8" Pan Hd. Slit. Tapt. T-20	(3)
15	06-82-7270	8-16 x 5/8" Pan Hd. Slit. Plas. T-20	(6)
16	44-60-0530	Ground Pin	(1)
17	06-82-7240	6-19 x 1/2" Pan Hd. Plastite T-15	(2)
18	06-95-0075	6-32 x 3/8" Truss Hd. Taptite T-10	(2)
19	12-99-1730	Service Nameplate	(1)
20	14-20-3020	Remote Dial Assembly	(1)
21	14-46-1001	Foam Slug Kit - 10 Slugs	(2)
★ 22	14-74-0270	Shoe Assembly	(1)
23	16-30-0540	120 V. Armature	(1)
24	22-84-0531	Fan Assembly	(1)
25	18-31-0500	120 V. Field	(1)
★ 26	22-18-0910	Carbon Brush Assembly	(2)
27	22-22-1380	Brush Holder Assembly	(1)
28	14-46-0840	Pin Housing Assembly Kit	(1)
29	48-76-4008	8' Quik-Lok Cord	(1)
31	23-44-0190	Brush Retaining Cap	(2)
33	23-66-1490	Switch	(1)
34	28-14-2176	Gear Case	(1)
35	28-28-1876	Diaphragm	(1)
36	31-50-0020	Motor Housing	(1)
37	30-72-0082	Primary Wobble Plate	(1)
38	30-72-0092	Secondary Wobble Plate	(1)

FIG.	PART NO.	DESCRIPTION OF PART	NO. REQ.
39	31-05-0055	Baffle	(1)
40	43-06-0685	Metal Disc	(1)
41	31-44-1661	Right Handle Half	(1)
42	31-44-1666	Left Handle Half	(1)
43	31-52-0010	Shoe Release Lever	(1)
44	31-15-0075	Plastic Collar	(1)
45	32-40-2099	Gear	(1)
46	34-40-1280	O-Ring	(1)
47	34-40-4200	O-Ring	(2)
48	34-60-1315	Ext. Retaining Ring	(2)
49	34-80-2600	Internal Retaining Ring	(3)
50	36-92-0701	Wobble Shaft	(1)
51	38-50-5835	Reciprocating Spindle	(1)
52	42-12-0150	Axle - Wobble Shaft	(1)
53	42-24-0430	Spindle Bearing	(1)
54	43-78-0525	Drive Hub	(1)
55	42-52-0380	Bearing Cap	(1)
56	31-15-0510	Spring Cover	(1)
57	42-87-0090	Counter Balance	(1)
58	44-60-1200	Lock Pin	(1)
59	44-86-0375	Seal Retainer	(1)
60	45-06-0475	Polypak Seal	(1)
61	45-06-0500	Felt Seal	(1)
62	45-12-0460	Gear Case Insulator	(1)
63	45-12-0470	Dust Shield	(1)
64	45-36-1450	Spacer	(1)
65	45-76-0320	Tube Chassis	(1)
66	45-88-8576	Washer	(2)
67	40-50-0160	Torsion Spring	(1)
68	40-50-0165	Compression Spring	(1)
69	43-72-0176	Heat Sink Holder	(1)
70	28-28-2000	Diaphragm Assembly	(1)
71	43-06-0675	Bronze Disc	(1)
72	40-50-8850	Disc Spring	(1)
73	42-50-0075	Cam Collar	(1)
74	44-60-0625	Pin	(1)
75	45-22-0080	Sleeve	(1)

MILWAUKEE ELECTRIC TOOL CORPORATION
13135 W. LISBON RD., BROOKFIELD, WI 53005

FIG. 1 NOTES:
1 Seal side faces commutator.

2 Seal side faces fan.

4 Press flush to diaphragm surface - Mechanism side.

40 Tabs engage drive hub.

71 Tabs engage gear.

72 Concave towards gear.

45/52 See sketch for press specifications.

5 Apply thread locking compound to threads of spinlock hex nut. Torque to 145 in./lbs. to 185 in./lbs.

5/45 Hold the intermediate gear assembly still with a large pair of pliers and a piece of rubber hose (or other tough, but pliable material to protect the gear from the jaws of the pliers) and remove the 5/16" spinlock hex nut with a wrench, as shown.

50/54 Make sure that the end of the wobble shaft fits into the offset (eccentric) recess, as shown.

34 Place 2-3/4 oz. of type "L" grease, No. 49-08-4175, in mechanism cavity of gear case.

35 Place 3/4 oz. of type "L" grease, No. 49-08-4175, in lower needle bearing-gear train cavity of diaphragm.

37/38/49 Internal retaining ring side faces center hub of wobble shaft.

46 Replace each time gear case mechanism is serviced. O-ring opening of diaphragm and rear of tube chassis must be free of all grease prior to o-ring installation.

49 Sharp side of retaining ring faces ball bearing.

60 O-ring of polypak seal faces mechanism - toward rear of tool.

61 Soak in lightweight lubricating oil prior to assembly.

63 Non-conductive insulation of wires must pass through rubber dust shield; Provides proper sealing of switch from contamination.

65 Assembled with large O.D. chamfered end facing diaphragm- can be slip or press fit on spindle bearing.

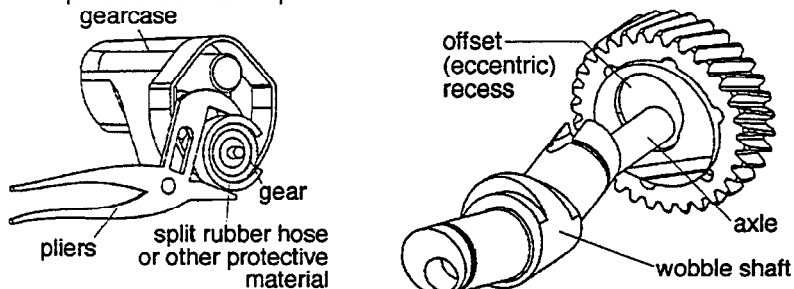
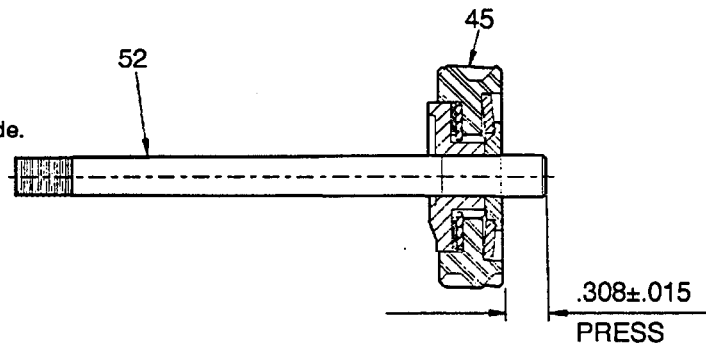

REMOVING THE KEYLESS QUIK-LOK BLADE CLAMP

44,51,56,66,
67,73,74,75

To remove keyless blade clamp, pry or press off plastic collar. Pop up the hinged tab on spring cover. Rotate cam collar until it stops fully open. While holding cam collar, insert Sawzall blade to push pin partially out. Insert a rigid wire-like instrument, like a paper clip with a slight bend on the end. Locate the pin area on inside slot and twist the paper clip to remove the pin from spindle. (Use of a strong magnet may also remove the pin from the spindle).



Clean all parts before reassembly.

73,74

If cam collar or pin is replaced, coat pin with powdered graphite.

44,56

Always replace plastic collar and spring cover when servicing.

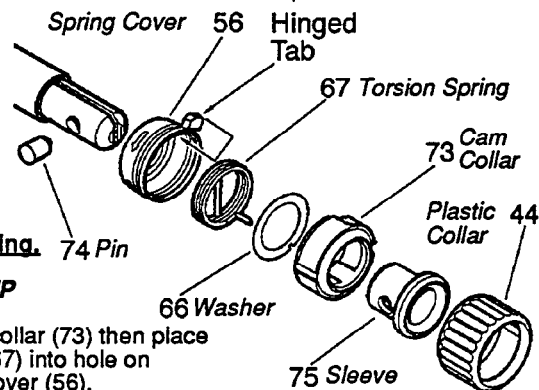

REASSEMBLY OF THE KEYLESS QUIK-LOK BLADE CLAMP

44,51,56,66,
67,73,74,75

To reassemble keyless blade clamp, place sleeve (75) in cam collar (73) then place washer (66) on sleeve (75). Insert spring leg of torsion spring (67) into hole on cam collar (73) and slot in washer (66). Cover up with spring cover (56).

Facing the front end of the tool, position reciprocating spindle with the pin hole facing up. Slide keyless blade clamp assembly onto the spindle with slot in cam collar (73) toward the left. Rotate the assembly in the direction of the arrows, approximately 205°. A ground pin may be used to keep the slot and sleeve hole in alignment until hole in spindle is reached. Use a pliers to hold assembly and remove ground pin. Pin (74) can now be inserted into clamp. Snap clamp to assure proper functioning before adding plastic collar (44). Fold hinged tab on spring cover (56) into slot on cam collar (73) as shown. Tab **must be present** to assure proper function. Slide plastic collar (44) onto assembly. Rotate plastic collar (44) until keyways line up and slide plastic collar (44) over snap in spring cover (56).