



SERVICE PARTS LIST

BULLETIN NO.
54-40-5075

SPECIFY CATALOG NO. AND SERIAL NO. WHEN ORDERING PARTS		REVISED BULLETIN	DATE
SUPER SAWZALL			Nov. '99
CATALOG NO.	6537	STARTING SERIAL NUMBER	884A
		WIRING INSTRUCTION 58-01-0266	

EXAMPLE:
Component Parts (Small #)
Are Included When Ordering
The Assembly (Large #).

00
0

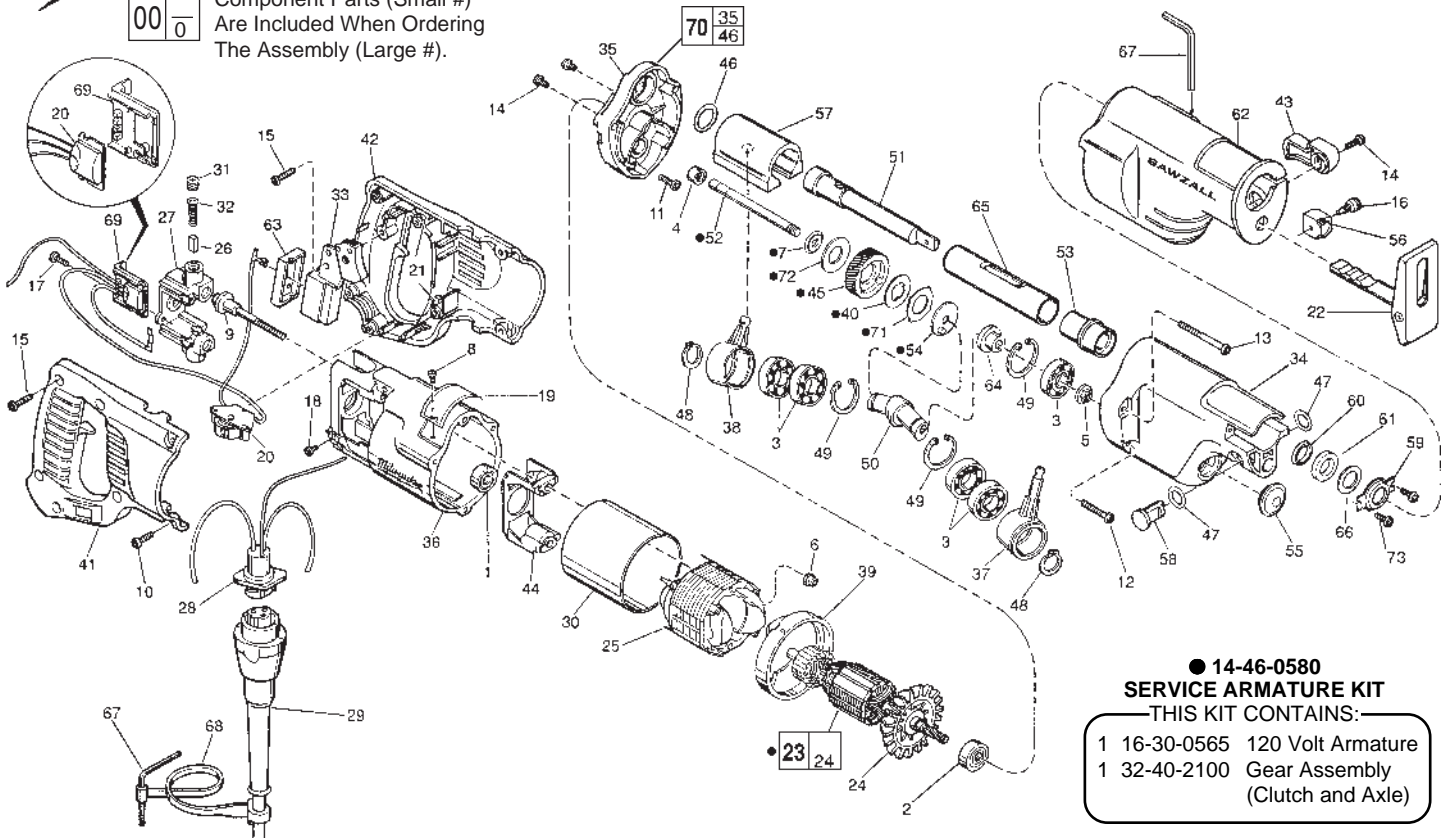

14-46-0580
SERVICE ARMATURE KIT
THIS KIT CONTAINS:
1 16-30-0565 120 Volt Armature
1 32-40-2100 Gear Assembly (Clutch and Axle)

FIG.	PART NO.	DESCRIPTION OF PART	NO. REQ.
1	02-04-0845	Ball Bearing	(1)
2	02-04-0911	Ball Bearing	(1)
3	02-04-1510	Ball Bearing	(5)
4	02-50-2150	Needle Bearing	(1)
5	06-55-3790	Spinlock Hex Nut 5/16-24	(1)
6	06-57-2975	8-32 Flexlock Hex Nut	(2)
7	-----	Rear Hub	(1)
8	06-72-1720	Nameplate Rivet	(2)
9	06-81-1060	8-32 x 2-1/4" Field Bolt	(2)
10	06-82-5316	8-32 x 1/2" Pan Hd. Slit. Tapt. T-20	(4)
11	06-82-5320	8-32 x 5/8" Pan Hd. Slit. Tapt. T-20	(1)
12	06-82-5390	8-32 x 1-1/4" Pan Hd. Slit. Tapt. T-20	(2)
13	06-82-5502	8-32 x 2-1/4" Pan Hd. Slit. Tapt. T-20	(2)
14	06-82-7252	8-32 x 3/8" Pan Hd. Slit. Tapt. T-20	(3)
15	06-82-7270	8-16 x 5/8" Pan Hd. Slit. Plas. T-20	(6)
16	06-83-2960	Blade Clamp Screw	(1)
17	06-95-0080	6-32 x 1/2" Truss Hd. Taptite	(2)
18	06-95-5150	6-32 x 1/4" Hex Hd. Taptite Sems	(1)
19	12-99-1730	Service Nameplate	(1)
20	14-20-3020	Remote Dial Assembly	(1)
21	14-46-1001	Foam Slug Kit - 10 Slugs	(2)
22	14-74-0260	Shoe Assembly	(1)
23	-----	120 V. Armature	(1)
24	22-84-0531	Fan Assembly	(1)
25	18-31-0500	120 V. Field	(1)
26	22-16-0275	Carbon Brush	(2)
27	22-22-1380	Brush Holder Assembly	(1)
28	22-56-0543	Pin Housing Assembly	(1)
29	48-76-4008	8' Quik-Lok Cord	(1)
30	23-16-0456	Field Insulator	(1)
31	23-44-0190	Brush Retaining Cap	(2)
32	23-52-0160	Brush Spring	(2)
33	23-66-1490	Switch	(1)
34	28-14-2176	Gear Case	(1)
35	28-28-1876	Diaphragm	(1)
36	28-50-6220	Motor Housing	(1)
37	30-72-0082	Primary Wobble Plate	(1)
38	30-72-0092	Secondary Wobble Plate	(1)
39	31-05-0055	Baffle	(1)
40	-----	Metal Disc	(1)
41	31-44-1661	Right Handle Half	(1)

FIG.	PART NO.	DESCRIPTION OF PART	NO. REQ.
42	31-44-1666	Left Handle Half	(1)
43	31-52-0010	Shoe Release Lever	(1)
44	31-55-0190	Coil Shield	(1)
45	-----	Gear	(1)
46	34-40-1280	O-Ring	(1)
47	34-40-4200	O-Ring	(2)
48	34-60-1315	Ext. Retaining Ring	(1)
49	34-80-2600	Internal Retaining Ring	(3)
50	36-92-0701	Wobble Shaft	(1)
51	38-50-5831	Reciprocating Spindle	(1)
52	42-12-0150	Axle - Wobble Shaft	(1)
53	42-24-0430	Spindle Bearing	(1)
54	-----	Drive Hub	(1)
55	42-52-0380	Bearing Cap	(1)
56	42-68-0677	Blade Clamp	(1)
57	42-87-0090	Counter Balance	(1)
58	44-60-1200	Lock Pin	(1)
59	44-86-0375	Seal Retainer	(1)
60	45-06-0475	Polypak Seal	(1)
61	45-06-0500	Felt Seal	(1)
62	45-12-0460	Gear Case Insulator	(1)
63	45-12-0470	Dust Shield	(1)
64	45-36-1450	Spacer	(1)
65	45-76-0320	Tube Chassis	(1)
66	45-88-8576	Washer	(1)
67	49-96-0090	3/16" Allen Wrench	(2)
68	48-66-4080	Key Holder	(1)
69	43-72-0176	Heat Sink Holder	(1)
70	28-28-2000	Diaphragm Assembly	(1)
71	-----	Bronze Disc	(1)
72	-----	Disc Spring	(1)
73	06-95-0075	6-32 x 3/8" Truss Hd. Taptite	(2)

**SEE REVERSE SIDE FOR
IMPORTANT SERVICE NOTES**

MILWAUKEE ELECTRIC TOOL CORPORATION
13135 W. LISBON RD., BROOKFIELD, WI 53005

FIG.**NOTES:**

- 1 Seal side faces commutator.
- 2 Seal side faces fan.
- 4 Press flush to diaphragm surface - Mechanism side.
- 5 Apply thread locking compound to threads of spinlock hex nut.
Torque to 145 in./lbs. to 185 in./lbs.
- 34 Place 2-3/4 oz. of type "L" grease, No. 49-08-4175, in mechanism cavity of gear case.
- 35 Place 3/4 oz. of type "N" grease, No. 49-08-4230,
in lower needle bearing-gear train cavity of diaphragm.
- 37/38/49 Internal retaining ring side faces center hub of wobble shaft.
- 46 Replace each time gear case mechanism is serviced. O-ring opening of diaphragm
and rear of tube chassis must be free of all grease prior to o-ring installation.
- 49 Sharp side of retaining ring faces ball bearing.
- 56 Tab end faces forward -
toward shoe assembly
(Lessens blade breakage).
- 60 O-ring of polypak seal faces mechanism - toward rear of tool.
- 61 Soak in lightweight lubricating oil prior to assembly.
- 63 Non-conductive insulation of wires must pass through rubber dust shield;
Provides proper sealing of switch from contamination.
- 65 Assembled with large O.D. chamfered end facing diaphragm-
can be slip or press fit on spindle bearing.

