



# SERVICE PARTS LIST

BULLETIN NO.

54-40-5051

SPECIFY CATALOG NO. AND SERIAL NO. WHEN ORDERING PARTS		REVISED BULLETIN	DATE
<b>SUPER SAWZALL®</b>		54-40-5050	Apr. '92
CATALOG NO. <b>6528</b>	STARTING SERIAL NUMBER <b>775-31176</b>	WIRING INSTRUCTION <b>58-01-0255</b>	

**EXAMPLE:**  
Component Parts ( Small #)  
Are Included When Ordering  
The Assembly (Large #).

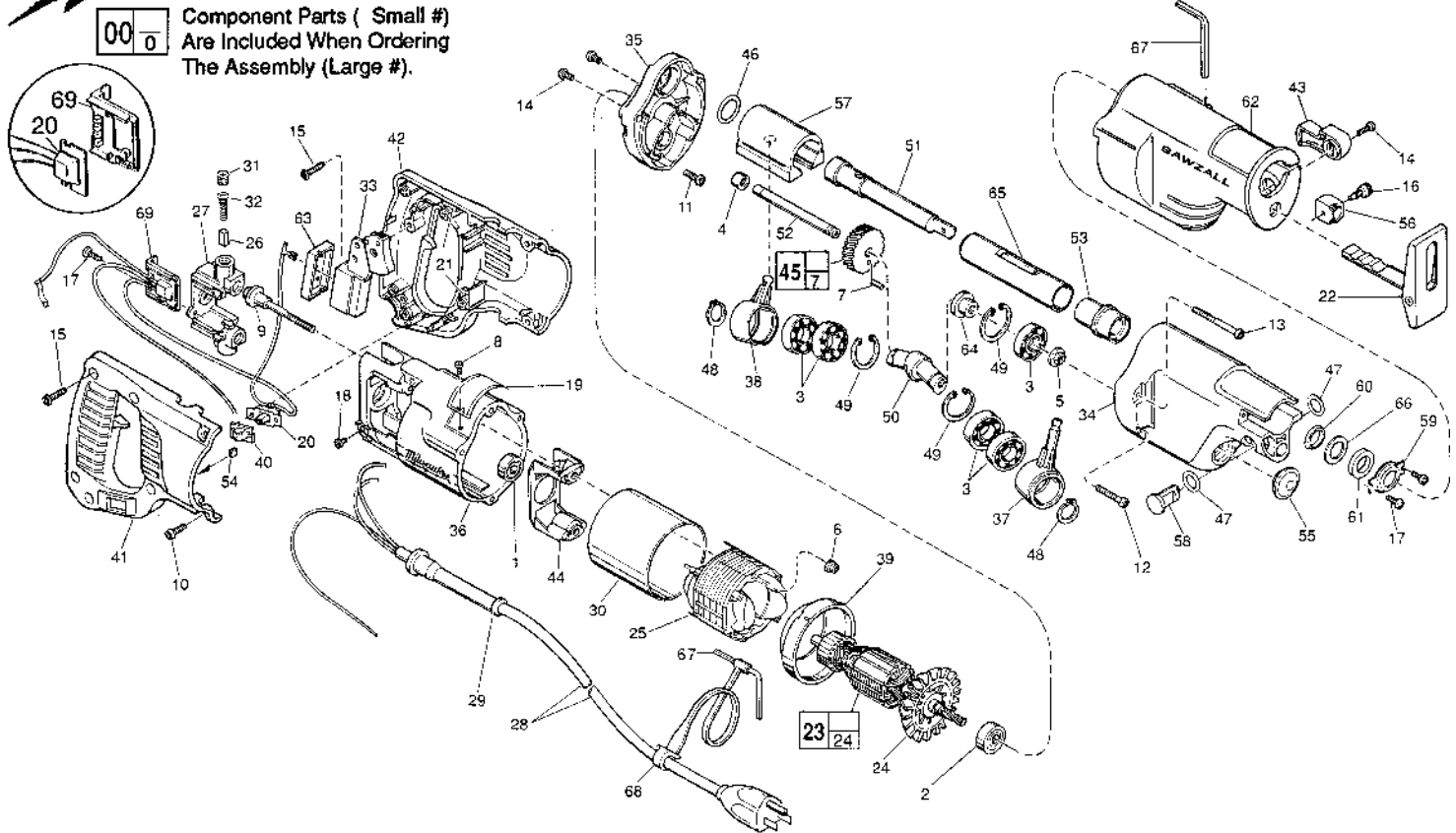

FIG.	PART NO.	DESCRIPTION OF PART	NO. REQ.	FIG.	PART NO.	DESCRIPTION OF PART	NO. REQ.
1	02-04-0845	Ball Bearing	(1)	43	31-52-0010	Shoe Release Lever	(1)
2	02-04-0911	Ball Bearing	(1)	★ 44	31-55-0190	Coil Shield	(1)
3	02-04-1510	Ball Bearing	(5)	★ 45	32-40-2223	Intermediate Gear Assembly	(1)
4	02-50-2150	Needle Bearing	(1)	46	34-40-1275	O-Ring	(1)
5	06-55-3790	Spinlock Hex Nut 5/16-24	(1)	47	34-40-4200	O-Ring	(2)
6	06-57-2975	8-32 Flexlock Hex Nut	(2)	48	34-60-1315	Ext. Retaining Ring	(2)
7		3/16 x 1/2" Drivlok Pin	(1)	49	34-80-2600	Internal Retaining Ring	(3)
8	06-85-0200	Nameplate Screw	(2)	50	36-92-0701	Wobble Shaft	(1)
★ 9	06-81-1060	8-32 x 2-1/4" Field Bolt	(2)	★ 51	38-50-5831	Reciprocating Spindle	(1)
10	06-82-5316	8-32 x 1/2" Pan Hd. Slit. Tapt. T-20	(4)	52	42-12-0150	Axle - Wobble Shaft	(1)
11	06-82-5320	8-32 x 5/8" Pan Hd. Slit. Tapt. T-20	(1)	53	42-24-0430	Spindle Bearing	(1)
12	06-82-5390	8-32 x 1-1/4" Pan Hd. Slit. Tapt. T-20	(2)	54	42-38-0240	Bumper	(2)
13	06-82-5502	8-32 x 2-1/4" Pan Hd. Slit. Tapt. T-20	(2)	55	42-52-0380	Bearing Cap	(1)
14	06-82-7252	8-32 x 3/8" Pan Hd. Slit. Tapt. T-20	(3)	56	42-68-0640	Blade Clamp	(1)
15	06-82-7270	8-16 x 5/8" Pan Hd. Slit. Plas. T-20	(6)	57	42-87-0090	Counter Balance	(1)
16	06-83-2960	Blade Clamp Screw	(1)	58	44-60-1200	Lock Pin	(1)
17	06-95-0075	6-32 x 3/8" Truss Hd. Taptite	(4)	59	44-86-0375	Seal Retainer	(1)
18	06-95-5150	6-32 x 1/4" Hex Hd. Taptite Sems	(1)	60	45-06-0475	Polypak Seal	(1)
19	12-99-0520	Nameplate Blank	(1)	61	45-06-0500	Felt Seal	(1)
★ 20	14-20-0276	Switch Module Assembly	(1)	62	45-12-0460	Gear Case Insulator	(1)
21	14-46-1001	Foam Slug Kit - 10 Slugs	(2)	63	45-12-0470	Dust Shield	(1)
22	14-74-0250	Shoe Assembly	(1)	64	45-36-1450	Spacer	(1)
23	16-30-0526	120 V. Armature	(1)	65	45-76-0320	Tube Chassis	(1)
24	22-84-0531	Fan Assembly	(1)	66	45-88-8220	Washer	(1)
★ 25	18-31-0500	120 V. Field	(1)	67	49-96-0090	3/16" Allen Wrench	(2)
26	22-16-0275	Carbon Brush	(2)	68	48-66-4080	Key Holder	(1)
★ 27	22-22-1380	Brush Holder Assembly	(1)	★ 69	43-72-0175	Heat Sink Holder	(1)
28	22-64-0155	Cord Set	(1)				
29	44-76-0210	Cord Protector	(1)				
30	23-16-0456	Field Insulator	(1)				
31	23-44-0190	Brush Retaining Cap	(2)				
32	23-52-0160	Brush Spring	(2)				
33	23-66-1490	Switch	(1)				
34	28-14-2176	Gear Case	(1)				
35	28-28-1871	Diaphragm	(1)				
★ 36	28-50-6211	Motor Housing	(1)				
★ 37	30-72-0082	Primary Wobble Plate	(1)				
★ 38	30-72-0092	Secondary Wobble Plate	(1)				
39	31-05-0050	Baffle	(1)				
40	31-12-0190	Switch Cap	(1)				
★ 41	31-44-1650	Right Handle Half	(1)				
42	31-44-1655	Left Handle Half	(1)				

**SEE REVERSE SIDE FOR  
IMPORTANT SERVICE NOTES**

**MILWAUKEE ELECTRIC TOOL CORPORATION**  
13135 W. LISBON RD., BROOKFIELD, WI 53005

- FIG. NOTES:**
- 1 Seal side faces commutator.
  - 2 Seal side faces fan.
  - 4 Press flush to diaphragm surface - Mechanism side.
  - 5 Apply thread locking compound to threads of spinlock hex nut. torque to 145 in./lbs. to 185 in./lbs.

7/45/52 See sketch for press specifications.

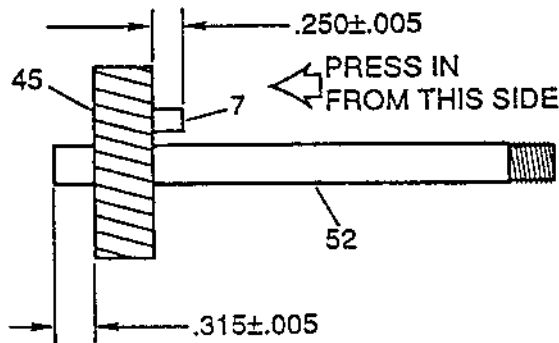

- 34 Place 2-3/4 oz. of type "L" grease, No. 49-08-4175, in mechanism cavity of gear case.
- 35 Place 3/4 oz. of type "L" grease, No. 49-08-4175, in lower needle bearing-gear train cavity of diaphragm.
- 37/38/49 Internal retaining ring side faces center hub of wobble shaft.
- 46 Replace each time gear case mechanism is serviced. O-ring opening of diaphragm & rear of tube chassis must be free of all grease prior to o-ring installation.
- 49 Sharp side of retaining ring faces ball bearing.

- 56 Tab end faces forward - toward shoe assembly (Lessens blade breakage).

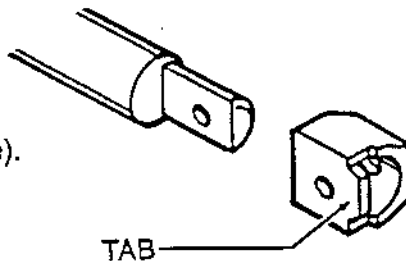

- 60 O-ring of polypak seal faces mechanism - toward rear of tool.
- 61 Soak in lightweight lubricating oil prior to assembly.
- 63 Non-conductive insulation of wires must pass through rubber dust shield; Provides proper sealing of switch from contamination.
- 65 Assembled with large O.D. chamfered end facing diaphragm- can be slip or press fit on spindle bearing.