



SERVICE PARTS LIST

BULLETIN NO.
54-40-5251

SPECIFY CATALOG NO. AND SERIAL NO. WHEN ORDERING PARTS		REVISED BULLETIN 54-40-5250	DATE Mar. 2008
ORBITAL SUPER SAWZALL®		WIRING INSTRUCTION 58-01-0784	
CATALOG NO. 6521-21	STARTING SERIAL NUMBER	981B	

FIG.	PART NO.	DESCRIPTION OF PART	QTY.
1	02-04-0845	Ball Bearing	(1)
2	02-04-0915	Ball Bearing	(1)
3	02-04-1510	Ball Bearing	(5)
4	02-50-2150	Needle Bearing	(1)
5	06-55-3790	Spinlock Hex Nut 5/16-24	(1)
6	06-55-0835	8-32 Hex Nut	(2)
7	45-88-1555	Washer	(1)
8	06-72-1720	Nameplate Rivet	(2)

★ = Part number change from previous service parts list.

Carbon brush assembly (26) 22-18-0925 is no longer available. Replacement carbon brush assembly, 22-18-0926, does not require spacer (78). Remove and discard (78) when installing new brush assembly.

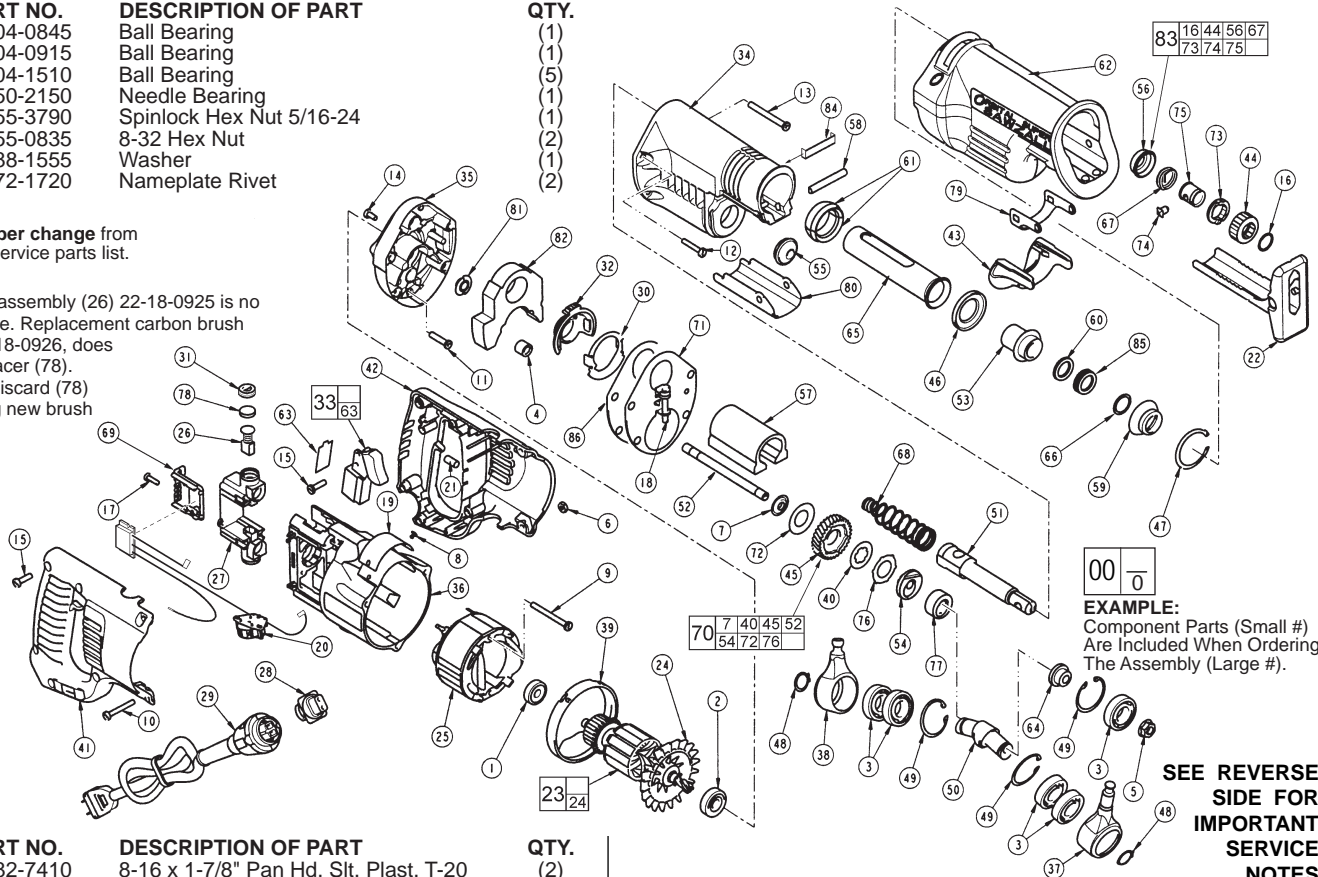

EXAMPLE:
Component Parts (Small #) Are Included When Ordering The Assembly (Large #).

SEE REVERSE SIDE FOR IMPORTANT SERVICE NOTES

FIG.	PART NO.	DESCRIPTION OF PART	QTY.
9	06-82-7410	8-16 x 1-7/8" Pan Hd. Slit. Plast. T-20	(2)
10	06-82-2390	8-32 x 1-1/4" Pan Hd. Slit. Tapt. T-20	(2)
11	05-88-8307	Pan Hd. PT T-20	(1)
12	06-82-5362	8-32 x 1" Pan Hd. Slit. Tapt. T-20	(2)
13	05-88-0300	K50 x 48mm Pan Hd. PT T-20	(2)
14	06-82-7252	8-32 x 3/8" Pan Hd. Slit. Tapt. T-20	(2)
15	06-82-7270	8-16 x 5/8" Pan Hd. Slit. Plas. T-20	(6)
16	34-60-3680	External Retaining Ring	(1)
17	06-82-7240	6-19 x 1/2" Pan Hd. Slit. Plast. T-15	(2)
18	43-36-0125	Cam Follower Assembly	(1)
19	12-99-1745	Service Nameplate	(1)
20	14-20-3020	Remote Dial Assembly	(1)
21	14-46-1001	Foam Slug Kit - 10 Slugs	(2)
22	45-16-0640	Shoe Assembly	(1)
23	16-30-0572	120 V. Armature	(1)
24	22-84-0531	Fan Assembly	(1)
25	18-31-0510	120 V. Field	(1)
26	22-18-0925	Carbon Brush Assembly	(2)
27	22-22-1385	Brush Holder Assembly	(1)
28	22-56-0690	Pin Housing Assembly	(1)
29	48-76-5010	10' Quik-Lok Cord	(1)
30	31-11-0130	Cam Plate-Orbital	(1)
31	23-44-0125	Brush Retaining Cap	(2)
32	31-15-0580	Collar	(1)
33	23-66-1965	Switch	(1)
34	28-14-2500	Gear Case	(1)
35	28-28-2500	Diaphragm	(1)
36	31-50-0020	Motor Housing	(1)
37	30-72-0085	Primary Wobble Plate	(1)
38	30-72-0093	Secondary Wobble Plate	(1)
39	31-05-0055	Baffle	(1)
40	43-06-0685	Metal Disc	(1)
41	31-44-1661	Right Handle Half	(1)
42	31-44-1666	Left Handle Half	(1)
★ 43	31-52-0021	Shoe Release Lever	(1)
44	42-50-0076	Front Cam	(1)
45	32-40-2090	Gear	(1)
46	45-88-3000	Washer	(1)
47	34-80-4600	Internal Retaining Ring	(1)
48	34-60-1315	Ext. Retaining Ring	(2)
49	34-80-2600	Internal Retaining Ring	(3)
50	36-92-0701	Wobble Shaft	(1)
51	38-50-6161	Reciprocating Spindle	(1)

FIG.	PART NO.	DESCRIPTION OF PART	QTY.
52	42-12-0225	Axle - Wobble Shaft	(1)
★ 53	42-24-0625	Spindle Bearing	(1)
54	43-78-0525	Drive Hub	(1)
55	42-52-0380	Bearing Cap	(1)
56	31-15-0511	Spring Cover	(1)
57	42-87-0125	Counter Balance	(1)
58	44-60-1627	Lock Pin	(1)
59	44-86-0630	Front Orbit Cap	(1)
60	45-06-0475	Polypak Seal	(1)
61	42-82-0075	Tube Retainer	(2)
62	45-12-0550	Gear Case Insulator	(1)
63	45-12-1967	Foam Seal	(1)
64	45-36-1450	Spacer	(1)
65	45-76-0500	Tube Chassis	(1)
66	45-88-8577	Washer	(1)
67	40-50-0161	Torsion Spring	(1)
68	40-50-0250	Compression Spring	(1)
69	43-72-0176	Heat Sink Holder	(1)
70	32-40-2104	IPS Gear Assembly (Orbital)	(1)
71	43-56-0625	Orbit Plate	(1)
72	40-50-8850	Disc Spring	(1)
73	42-50-0077	Rear Cam	(1)
74	44-60-0626	Pin	(1)
75	45-22-0081	Sleeve	(1)
76	43-06-0676	Bronze Disc	(1)
77	43-78-0528	Orbit Hub	(1)
78	23-50-0020	Spacer	(2)
★ 79	44-66-0386	Plate-Shoe Release Lever	(1)
80	44-66-0890	Plate-Shoe Retainer	(1)
81	45-28-0500	Grease Slinger	(1)
82	45-06-0715	Foam Seal	(1)
83	14-46-1011	Steel Quik-Lok Blade Clamp	(1)
84	42-70-5225	Shoe Stop Clip	(1)
85	45-06-0501	Felt Seal	(1)
86	43-44-0625	Gasket	(1)

FIG. NOTES:

- 1 Seal side faces commutator.
- 4 Press flush to diaphragm surface - Mechanism side.
- 40,45 Apply a thin coat of type "T" grease (Cat. No. 49-08-4290) between gear and metal disc.
- 40 Tabs engage drive hub.
- 76 Tabs engage gear.
- 72 Concave towards gear.
- 45,52 See sketch for press specifications.
- 5 Apply green loctite 609 or 620 to threads of spinlock hex nut. Torque to 180 in./lbs. to 210 in./lbs.
- 5,45 Hold the gear still with a large pair of pliers and a piece of rubber hose (or other tough, but pliable material to protect the gear from the jaws of the pliers) and remove the 5/16" spinlock hex nut with a wrench, as shown.
- 50,54,77 When assembling, insert end of orbit hub into pocket of drive hub, then insert wobble shaft into pocket of orbit hub, as shown.
- 34 Place 2-3/4 oz. of type "T" grease (Cat. No. 49-08-4290), in mechanism cavity of gear case.
- 35 Place 3/4 oz. of type "T" grease (Cat. No. 49-08-4290), in lower needle bearing-gear train cavity of diaphragm.
- 37,38,49 Internal retaining ring side faces center hub of wobble shaft.
- 49 Sharp side of retaining ring faces ball bearing.
- 60 O-ring of polypak seal faces mechanism - toward rear of tool.
- 85 Soak in lightweight bushing oil prior to assembly.
- 74 Pin to be coated with graphite prior to assembly.
- 43,79 Square plastic tabs in shoe release lever should snap into square holes of shoe release lever plate.
- 81 Shoulder extension should face bearing.

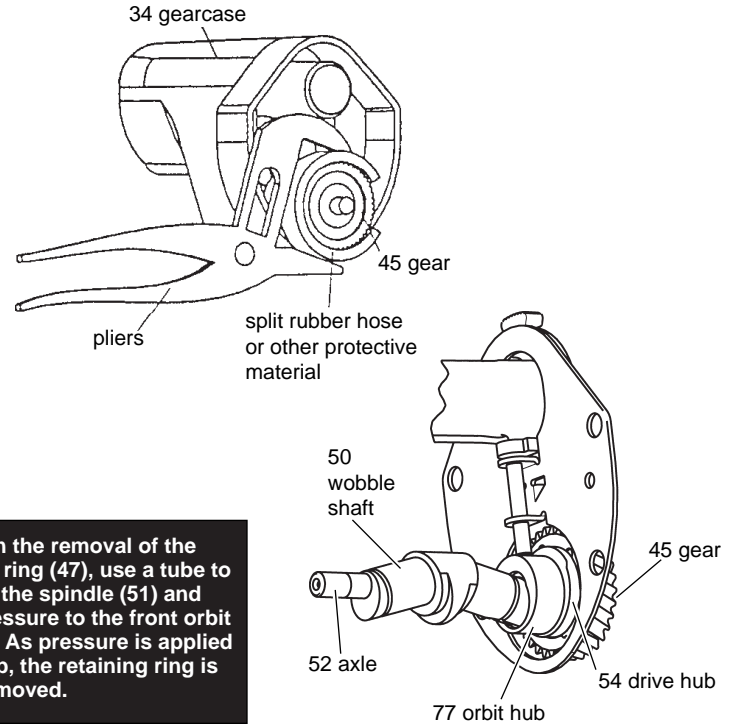
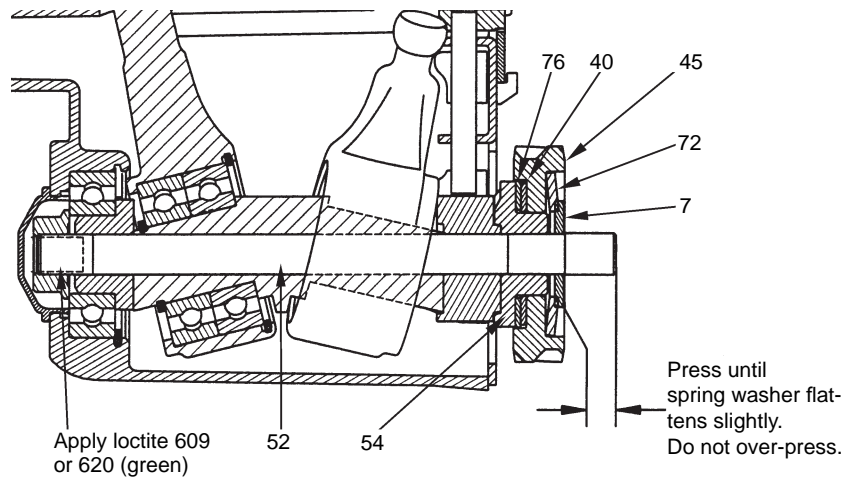

To help in the removal of the retaining ring (47), use a tube to slip over the spindle (51) and apply pressure to the front orbit cap (59). As pressure is applied to the cap, the retaining ring is easily removed.

REMOVING THE STEEL QUIK-LOK® BLADE CLAMP

- Remove external retaining ring (16) and pull front cam (44) off.
- Pull lock pin (74) out and remove remainder of parts and discard.

REASSEMBLY OF THE STEEL QUIK-LOK® BLADE CLAMP

- Coat new lock pin with powdered graphite.
- Hold tool in a vertical position.
- Place spring cover (56) onto spindle.
- Slide torsion spring (67) onto spindle with spring leg on hole side of spindle.
- Slide sleeve (75) onto spindle aligning hole on sleeve with hole in spindle.
- Slide rear cam (73) over sleeve until it bottoms on sleeve shoulder, ensure spring leg inserts into hole in rear cam.
- Rotate rear cam in the direction of the arrows located on spring cover until there is clearance for lock pin (74) to be inserted into sleeve/spindle holes. Insert lock pin.
- Align front cam (44) inner ribs with rear cam outer slots and slide front cam onto sleeve until it bottoms. Retaining ring (16) groove should be completely visible.
- Attach retaining ring by separating coils and inserting end of ring into groove, then wind remainder of ring into groove. Ensure ring is seated in groove.
- Blade clamp should rotate freely. During normal usage, debris may not allow blade clamp to rotate freely. The use of spray lubricant can help free blade clamp. In extreme conditions, follow these instructions to remove, clean and reassemble blade clamp.

