

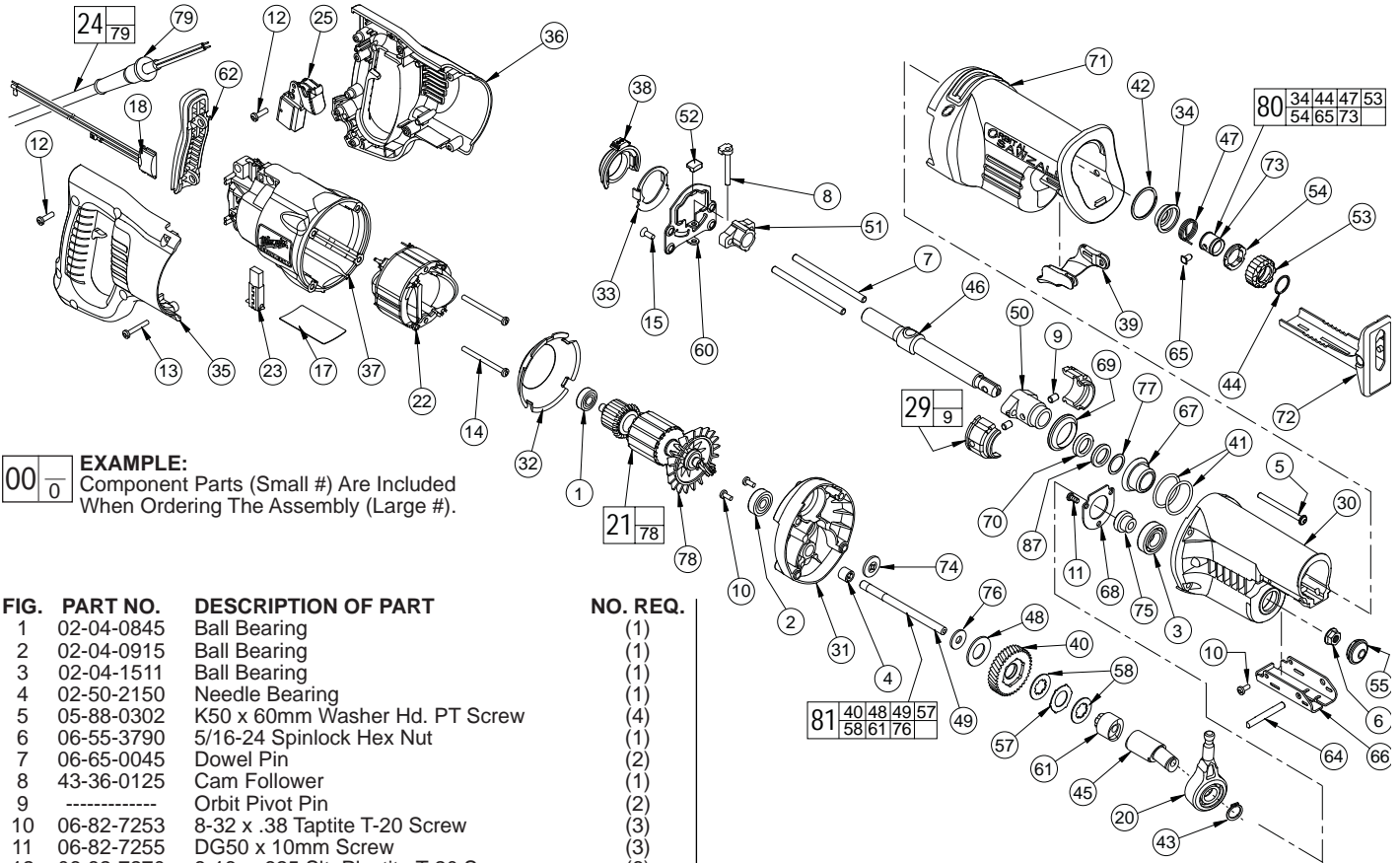

SERVICE PARTS LIST

BULLETIN NO.
54-40-7593

SPECIFY CATALOG NO. AND SERIAL NO. WHEN ORDERING PARTS		REVISED BULLETIN 54-40-7592	DATE May 2012
1-1/8" STROKE DOUBLE INSULATED SAWZALL®			
CATALOG NO.	6520-21	STARTING SERIAL NO.	B02D
			WIRING INSTRUCTION 58-01-0056



EXAMPLE:
Component Parts (Small #) Are Included When Ordering The Assembly (Large #).

FIG.	PART NO.	DESCRIPTION OF PART	NO. REQ.
	1	02-04-0845 Ball Bearing	(1)
	2	02-04-0915 Ball Bearing	(1)
	3	02-04-1511 Ball Bearing	(1)
	4	02-50-2150 Needle Bearing	(1)
	5	05-88-0302 K50 x 60mm Washer Hd. PT Screw	(4)
	6	06-55-3790 5/16-24 Spinlock Hex Nut	(1)
	7	06-65-0045 Dowel Pin	(2)
	8	43-36-0125 Cam Follower	(1)
	9	Orbit Pivot Pin	(2)
	10	06-82-7253 8-32 x .38 Taprite T-20 Screw	(3)
	11	06-82-7255 DG50 x 10mm Screw	(3)
	12	06-82-7270 8-16 x .625 Slit. Plastite T-20 Screw	(6)
	13	06-82-7326 8-16 x 1" Slit. Plastite T-20 Screw	(2)
	14	06-82-7453 8-16 x 2025 Slit. Plastite T-20 Screw	(2)
	15	06-82-8870 1/2-DG50 Thread Form Screw	(4)
★	17	12-99-2576 Service Nameplate	(1)
	18	14-20-3151 Remote Electronics Assembly	(1)
	20	14-67-0136 Primary Wobble Plate Assembly	(1)
	21	16-30-0700 Service Armature	(1)
	22	18-30-1700 Service Field	(1)
	23	22-20-0590 Carbon Brush Assembly	(2)
★	24	22-64-1123 Cord Assembly	(1)
	25	23-66-0205 Switch	(1)
	29	14-30-0080 Orbit Pocket Assembly	(2)
	30	28-14-2600 Gearcase	(1)
	31	28-28-2600 Diaphragm	(1)
	32	31-05-0155 Baffle	(1)
	33	31-11-0130 Orbital Cam Plate	(1)
	34	31-15-0170 Spring Cover	(1)
★	35	31-44-2505 Handle Half - Right	(1)
★	36	31-44-2506 Handle Half - Left	(1)
	37	31-50-0085 Motor Housing	(1)
	38	31-52-0045 Orbit Shift Lever	(1)
	39	31-52-0090 Shoe Release Lever	(1)
	40	32-40-2050 Intermediate Gear	(1)
	41	34-40-0040 O-Ring	(2)
	42	34-60-0125 Retaining Ring	(1)
	43	34-60-1315 External Retaining Ring	(1)
	44	34-60-3700 Retaining Ring	(1)
	45	36-92-0506 Wobble Shaft	(1)
	46	38-50-6400 Reciprocating Spindle	(1)
	47	40-50-0162 Torsion Spring	(1)
	48	40-50-8850 Disc Spring	(1)
	49	42-12-0190 Wobble Shaft Axle	(1)
	50	42-24-0066 Front Spindle Bushing	(1)
	51	42-24-0525 Rear Spindle Bushing	(1)
	52	42-38-0055 Orbit Bumper	(1)
	53	42-50-0355 Front Cam	(1)
	54	42-50-0360 Rear Cam	(1)
	55	42-52-0380 Bearing Cap	(1)
	57	43-06-0676 Bronze Plate	(1)

FIG.	PART NO.	DESCRIPTION OF PART	NO. REQ.
	58	43-06-0685 Metal Plate	(2)
	60	43-56-0620 Orbit Plate	(1)
★	61	43-78-0577 Orbit Drive Hub	(1)
	62	44-52-0105 Cushion Grip	(1)
	64	44-60-1635 Shoe Pin	(1)
	65	44-60-1750 Lock Pin	(1)
	66	44-66-0880 Shoe Retainer	(1)
	67	44-86-0035 Front Orbit Cap	(1)
	68	44-86-0655 Bearing Retainer	(1)
	69	45-06-0110 Orbit Seal	(1)
	70	45-06-0475 Polypak Seal	(1)
	71	45-12-0710 Gearcase Insulator	(1)
	72	45-16-0645 Shoe Assembly	(1)
	73	45-22-0175 Sleeve	(1)
	74	45-28-0555 Slinger	(1)
	75	45-36-1445 Spacer	(1)
	76	45-88-1555 Washer	(1)
	77	45-88-8577 Washer	(1)
	78	22-84-0531 Fan	(1)
	79	44-76-0210 Cord Protector	(1)
	80	14-46-1060 Large Quik-Lok Blade Clamp	(1)
	81	14-08-0075 Gear Protecting Clutch Assembly	(1)
	87	45-06-0501 Felt Seal	(1)
		23-94-6750 Leadwire Assembly (Not Shown)	(1)
		23-94-6755 Leadwire Assembly (Not Shown)	(1)
		48-55-2055 Carrying Case (Not Shown)	(1)

SEE REVERSE SIDE FOR IMPORTANT SERVICE NOTES

FIG. 1

NOTES:

Bearing to be installed with seal towards commutator.

4,31 Press needle bearing flush $\pm .005$ with inner surface of diaphragm.

6,49 Apply Blue Loctite® 242 to treads of wobble shaft axle prior to installing spinlock hex nut. Torque spinlock hex nut to 160-190 in. lbs.

6,40 Hold the intermediate gear still with a large pair of pliers and a piece of rubber hose (or other tough, but pliable material to protect the gear from the jaws of the pliers) and remove the 5/16" spinlock hex nut with a wrench, as shown.

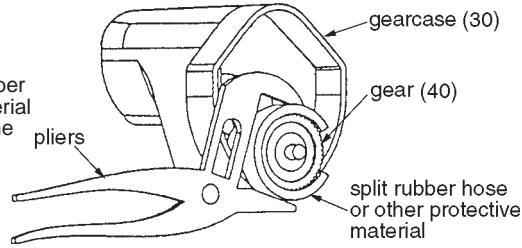

7,46,50,51 Press dowel pins flush to front side of front spindle bushing. Press dowel pins flush to back side of rear spindle bushing. **NOTE:** Reciprocating spindle (46) must be installed inside assembly (7,50) and (7,51) prior to pressing last spindle bushing into place.

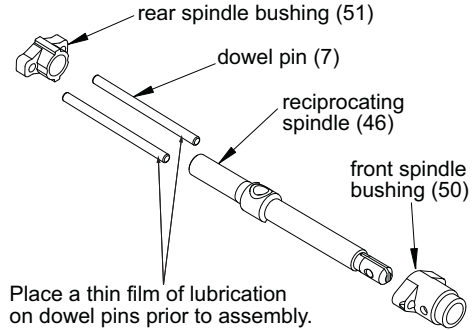

17,37 Install nameplate in motor housing recess prior to assembling diaphragm onto motor housing.

29,42 **Service fixture #61-10-0205** must be used when installing retaining ring (42) onto orbit pocket assembly (29).

40,57 Tabs of bronze plate engage intermediate gear.

40,48 Concave side of disc spring towards intermediate gear.

58,61 Tabs of metal plates engage orbit drive hub.

70 O-ring of polypak seal faces mechanism - toward rear of tool.

74 Shoulder extension of grease slinger should face bearing.

REMOVING THE STEEL QUIK-LOK® BLADE CLAMP

- Remove external retaining ring (44) and pull front cam (53) off.
- Pull lock pin (65) out and remove remainder of parts and discard.

REASSEMBLY OF THE STEEL QUIK-LOK® BLADE CLAMP

- Coat new lock pin with powdered graphite.
- Hold tool in a vertical position.
- Place spring cover (34) onto spindle.
- Slide torsion spring (47) onto spindle shaft with leg positioned at the 6:00 position.
- Slide sleeve (73) onto spindle aligning hole on sleeve with hole in spindle.
- Slide rear cam (54) over sleeve, aligning hole in rear cam with spring leg. Ensure spring leg inserts into hole in rear cam.
- Rotate rear cam (54) counter clockwise until there is clearance for lock pin (65) to be inserted into sleeve/spindle holes. Insert lock pin.
- Align front cam (53) inner ribs with rear cam outer slots (*see insert*) and slide front cam onto sleeve until it bottoms. Retaining ring (44) groove should be completely visible.
- Attach retaining ring by separating coils and inserting end of ring into groove, then wind remainder of ring into groove. Ensure ring is seated in groove.
- Blade clamp should rotate freely. During normal usage, debris may not allow blade clamp to rotate freely. The use of spray lubricant can help free blade clamp. In extreme conditions, follow these instructions to remove, clean and reassemble blade clamp.

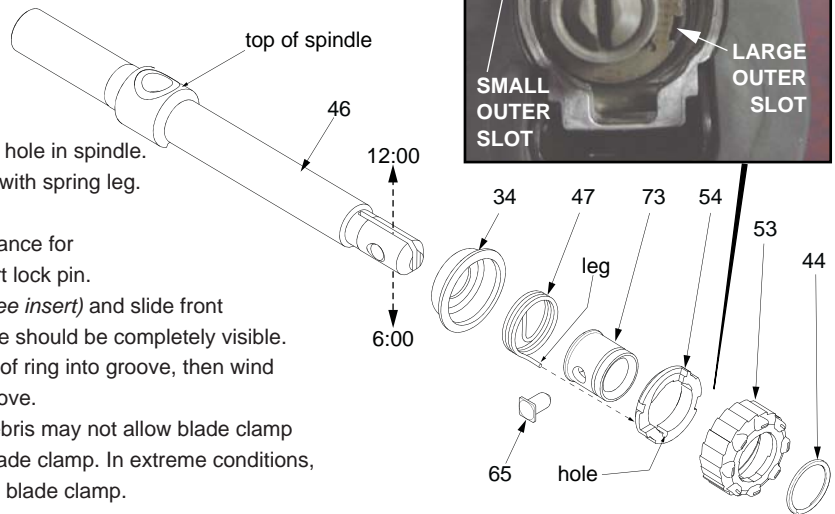

FIG. LUBRICATION:

29,41 Lightly coat o-rings with lubrication for ease of installation onto assembled orbit pockets.

30 Place 3.2 oz. (80 grams \pm 8 grams) of type "T" grease (Cat. No. 49-08-4290), in mechanism cavity of gear case.

31 Place .8 oz. (20 grams \pm 2 grams) of type "T" grease (Cat. No. 49-08-4290), in lower needle bearing-gear train cavity of diaphragm.

40,58 Apply a thin coat of type "T" grease (Cat. No. 49-08-4290) between gear and metal plate.

65 Pin to be coated with graphite prior to assembly.

87 Soak in lightweight bushing oil prior to assembly.

