



SERVICE PARTS LIST

BULLETIN NO.
55-40-6581

SPECIFY CATALOG NO. AND SERIAL NO. WHEN ORDERING PARTS		REVISED BULLETIN 55-40-6580	DATE May 2018
SAWZALL® Reciprocating Saw			
CAT. NO.	6519-59A	STARTING SERIAL NO.	D81B
		WIRING INSTRUCTION See Page 4	

EXAMPLE:
Component Parts (Small #)
Are Included When Ordering
The Assembly (Large #).

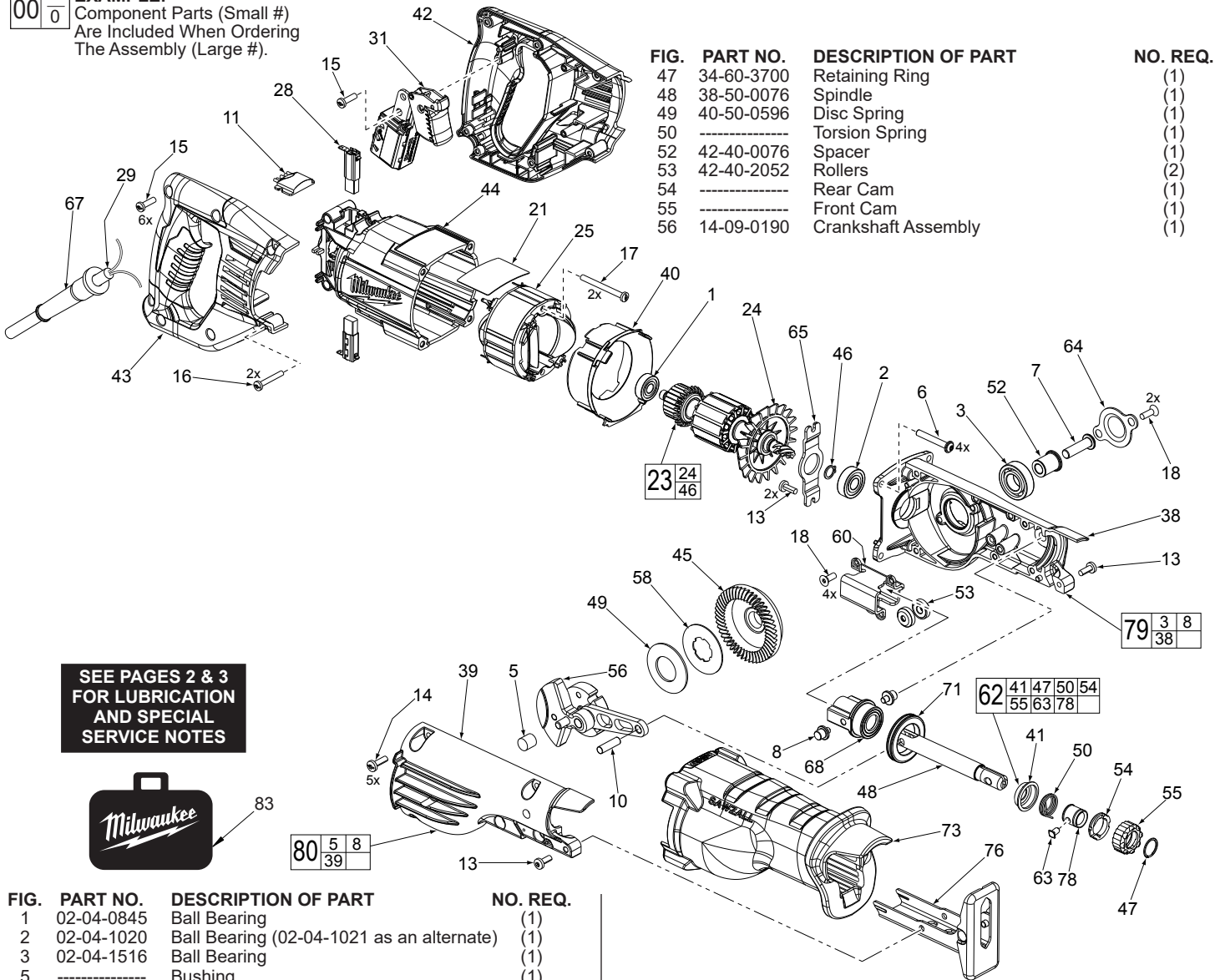

**SEE PAGES 2 & 3
FOR LUBRICATION
AND SPECIAL
SERVICE NOTES**

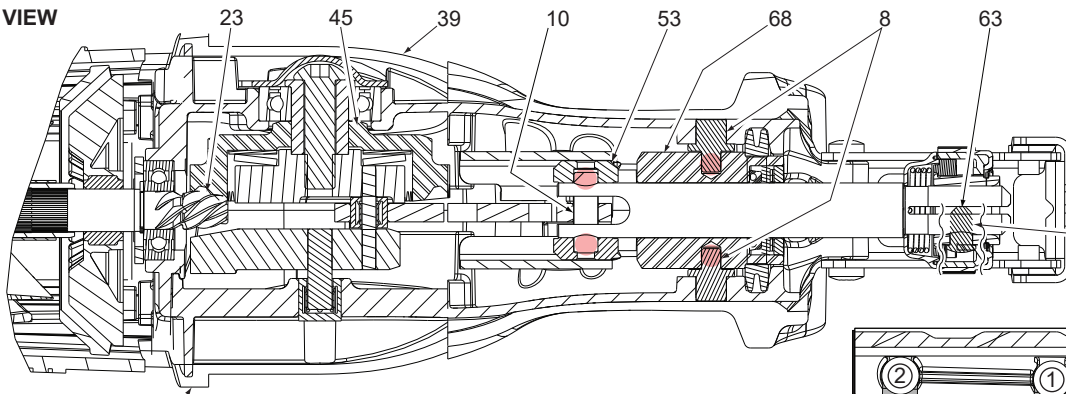

FIG.	PART NO.	DESCRIPTION OF PART	NO. REQ.
1	02-04-0845	Ball Bearing	(1)
2	02-04-1020	Ball Bearing (02-04-1021 as an alternate)	(1)
3	02-04-1516	Ball Bearing	(1)
5	-----	Bushing	(1)
6	05-88-8309	K50 x 35mm Washer Hd. PT T-20 Screw	(4)
7	06-08-0017	Drive Hub Bolt (R.H. Thread)	(1)
8	06-65-0135	Pivot Pin	(2)
10	06-65-0145	Pin - Connecting Rod	(1)
11	14-20-3160	Remote Electronics Assembly	(1)
13	06-82-5314	10-24 x .5 Pan Hd. Tapt. T-25 Screw	(4)
14	06-82-5411	10-24 x .625 Pan Hd. Tapt. T-25 Screw	(5)
15	06-82-7270	8-16 x .625 Pan Hd. Slit. Plast. T-20 Screw	(6)
16	06-82-7326	8-16 x 1.00 Pan Hd. Slit. Plast. T-20 Screw	(2)
17	06-82-7410	8-16 x 1.875 Pan Hd. Slit. Plast. T-20 Screw	(2)
18	06-82-8870	1/2-DG50 Thread Form T-20 Screw	(6)
21	-----	Service Nameplate	(1)
23	16-34-0305	Service Armature	(1)
24	22-84-0531	Fan	(1)
25	18-32-0300	Service Field	(1)
28	22-20-0055	Carbon Brush Assembly	(2)
29	22-64-0151	Cordset	(1)
31	23-66-0208	Switch	(1)
38	28-14-0045	Gearcase - Left	(1)
39	28-14-0046	Gearcase - Right	(1)
40	31-05-0195	Baffle	(1)
41	-----	Spring Cover	(1)
42	31-44-0810	Handle - Left	(1)
43	31-44-0815	Handle - Right	(1)
44	31-50-0290	Motor Housing	(1)
45	32-05-0022	Bevel Gear Service Kit	(1)
46	34-60-0810	External Retaining Ring	(1)

FIG.	PART NO.	DESCRIPTION OF PART	NO. REQ.
47	34-60-3700	Retaining Ring	(1)
48	38-50-0076	Spindle	(1)
49	40-50-0596	Disc Spring	(1)
50	-----	Torsion Spring	(1)
52	42-40-0076	Spacer	(1)
53	42-40-2052	Rollers	(2)
54	-----	Rear Cam	(1)
55	-----	Front Cam	(1)
56	14-09-0190	Crankshaft Assembly	(1)

FIG.	PART NO.	DESCRIPTION OF PART	NO. REQ.
58	43-06-0025	Metal Plate	(1)
60	43-56-0045	Orbit Slot	(1)
62	14-46-1062	Quik-Lok Blade Clamp Kit	(1)
63	-----	Lock Pin	(1)
64	44-66-0280	Bearing Retaining Plate - Gearcase Bearing	(1)
65	44-66-1070	Bearing Retaining Plate - Armature Bearing	(1)
67	44-76-0210	Cord Protector	(1)
68	14-86-0105	Front Bushing Assembly	(1)
71	45-06-0230	'H' Seal	(1)
73	45-12-2056	Insulator	(1)
76	45-16-0030	Shoe Assembly	(1)
78	-----	Sleeve	(1)
79	14-30-0145	Left Gearcase Assembly	(1)
80	14-30-0146	Right Gearcase Assembly	(1)
82	22-56-0451	Terminal Block (See Wiring Diagram)	(1)
83	42-55-2051	Carrying Case	(1)
	23-94-0100	Leadwire Assembly - Black (Not Shown)	(1)
	23-94-0530	Leadwire Assembly - Black (L3) (Not Shown)	(1)
	23-94-0540	Leadwire Assembly - White (L4) (Not Shown)	(1)
	23-94-0550	Leadwire Assembly - White (L5) (Not Shown)	(1)

TOP VIEW



Pin (63) is to be coated with graphite prior to assembly.

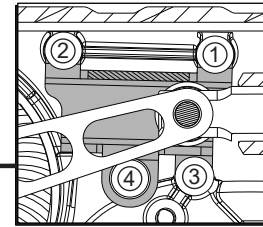

When securing the orbit slot (60), tighten screws (18) in the order shown.

SIDE VIEW

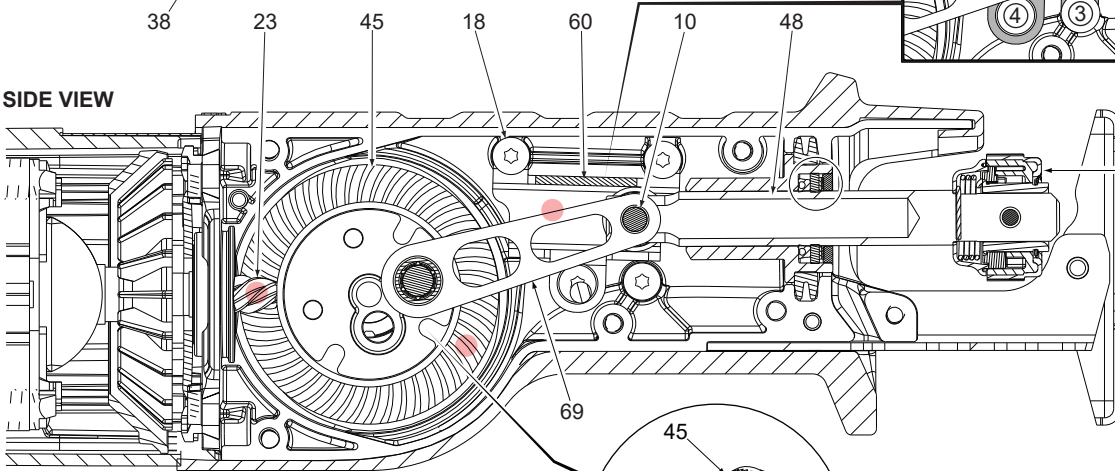

See next page for servicing of the Quik-Lok® Blade Clamp Assembly.

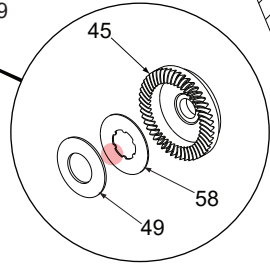

Concave side of disc spring (49) must face toward metal plate (58) and gear assembly (45).

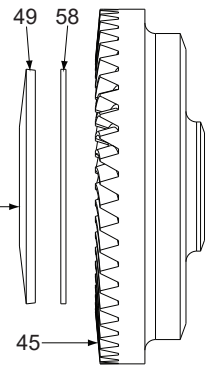

SPECIAL LUBRICATION SERVICE NOTE:

When servicing, use a clean, dry cloth to remove grease from gear assemblies. Remove 90-95% of the existing grease from tool prior to installing Type 'L' Grease. Original grease may be similar in color but is not compatible with 'L'.

LUBRICATION: Type 'L' Grease

No. 49-08-4175 (16 oz. tub)

- Place 30g ±3g (approx. 1 ounce) on top of gear (45) and armature pinion (23), being sure to cover the middle of the gear and all teeth.
- Place 15g ±3g (approx. .5 ounce) to the area where the gear (45) and the connecting rod (69) interface.
- Coat both sides of the metal clutch plate (58).
- Lightly coat both pins (8) where connections go into holes of front bushing assembly (68).
- Lightly coat both ends of pin (10) prior to installing rollers (53).

BACK VIEW

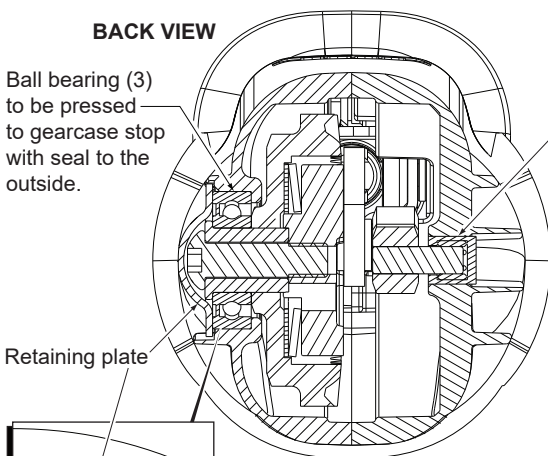

Ball bearing (3) to be pressed to gearcase stop with seal to the outside.

Press needle bearing (5) flush to subflush .005".

Retaining plate

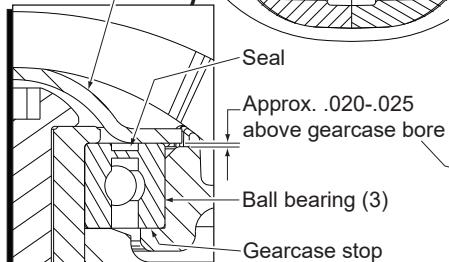

Seal
Approx. .020-.025 above gearcase bore
Ball bearing (3)
Gearcase stop

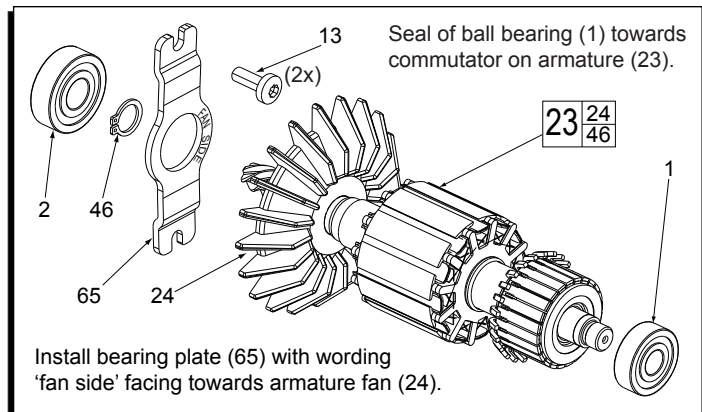

Seal of ball bearing (1) towards commutator on armature (23).

Install bearing plate (65) with wording 'fan side' facing towards armature fan (24).

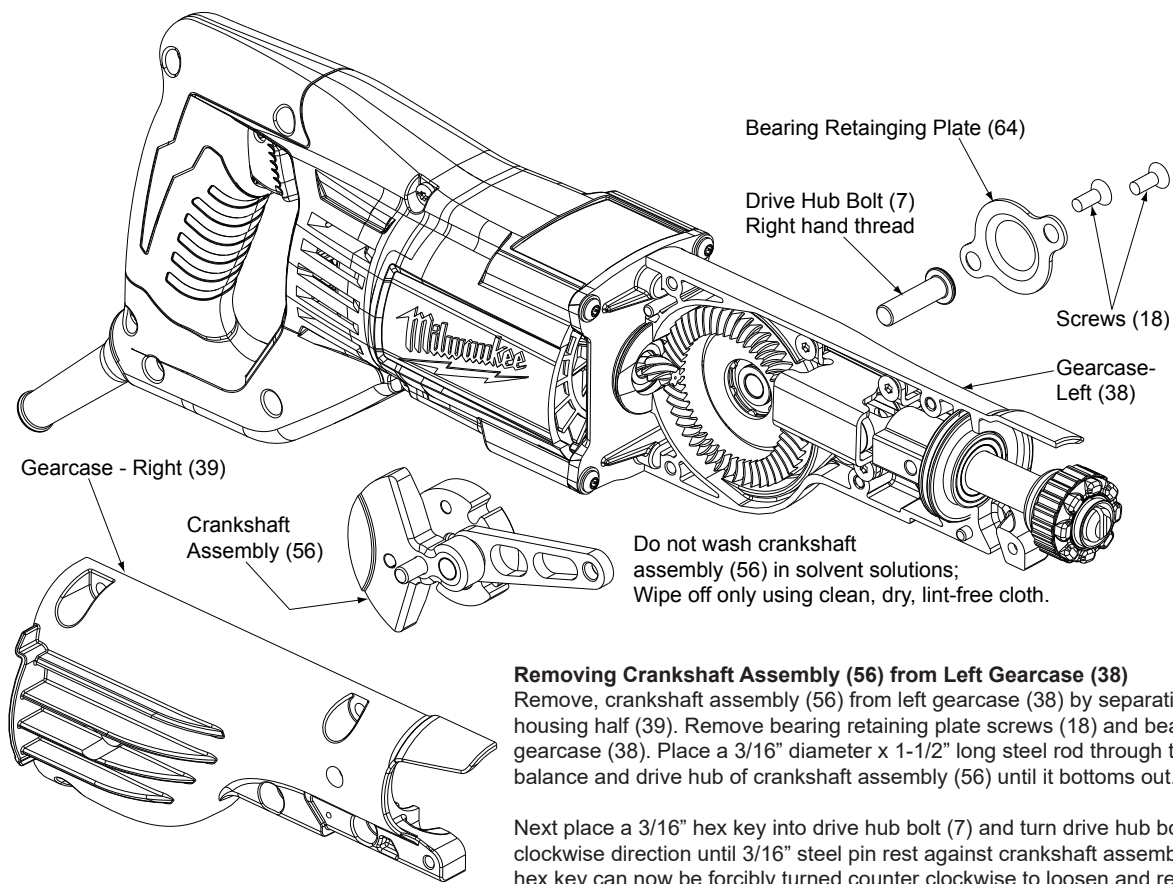

Removing Crankshaft Assembly (56) from Left Gearcase (38)

Remove crankshaft assembly (56) from left gearcase (38) by separating / removing right housing half (39). Remove bearing retaining plate screws (18) and bearing plate (64) from left gearcase (38). Place a 3/16" diameter x 1-1/2" long steel rod through the holes found in the counter balance and drive hub of crankshaft assembly (56) until it bottoms out.

Next place a 3/16" hex key into drive hub bolt (7) and turn drive hub bolt slowly in a counter clockwise direction until 3/16" steel pin rest against crankshaft assembly connecting rod. The 3/16" hex key can now be forcibly turned counter clockwise to loosen and remove drive hub bolt (7).

Reinstalling Crankshaft Assembly (56) into Left Gearcase (38)

To reinstall drive hub bolt (7) to crankshaft assembly (56) apply Blue Loctite® (44-20-0090) to threads of drive hub bolt (7) and insert through spacer (52) aligning threads of drive hub bolt (7) with internal threads of crankshaft assembly hub. Use a 3/16" hex key to turn the drive hub bolt (7) slowly in a clockwise direction until 3/16" steel pin rest against crankshaft assembly connecting rod (See 'Removing Crankshaft Assembly' instructions above). Using an inch pound torque wrench and a 3/16" hex key, torque drive hub bolt (7) to 210-240 in. lbs. or bolt can be tightened using a ft. lbs. torque wrench to 17-20 ft. lbs.

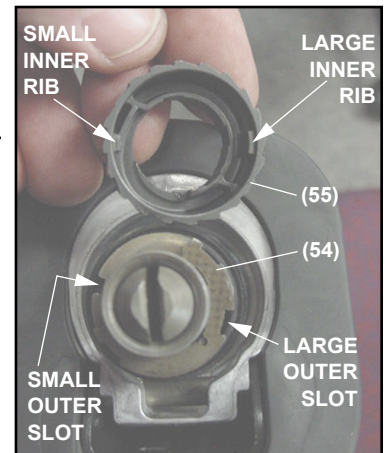

REMOVING THE STEEL QUIK-LOK® BLADE CLAMP

- Remove external retaining ring (47) and pull front cam (55) off.
- Pull lock pin (63) out and remove remainder of parts and discard.

REASSEMBLY OF THE STEEL QUIK-LOK® BLADE CLAMP

- Coat new lock pin (63) with powdered graphite.
- Hold tool in a vertical position.
- Place spring cover (41) onto spindle.
- Slide torsion spring (50) onto spindle shaft with leg positioned at the 6:00 position.
- Slide sleeve (78) onto spindle aligning hole in spindle.
- Slide rear cam (54) over sleeve, aligning hole in rear cam with spring leg. Ensure spring leg inserts into hole in rear cam.
- Rotate rear cam (54) counter clockwise until there is clearance for lock pin (63) to be inserted into sleeve/spindle holes. Insert lock pin.
- Align front cam (55) inner ribs with rear cam outer slots (see insert) and slide front cam onto sleeve until it bottoms. Retaining ring (47) groove should be completely visible.
- Attach retaining ring by separating coils and inserting end of ring into groove, then wind remainder of ring into groove. Ensure ring is seated in groove.
- Blade clamp should rotate freely. During normal usage, debris may not allow blade clamp to rotate freely. The use of spray lubricant can help free blade clamp. In extreme conditions, follow these instructions to remove, clean and reassemble blade clamp.

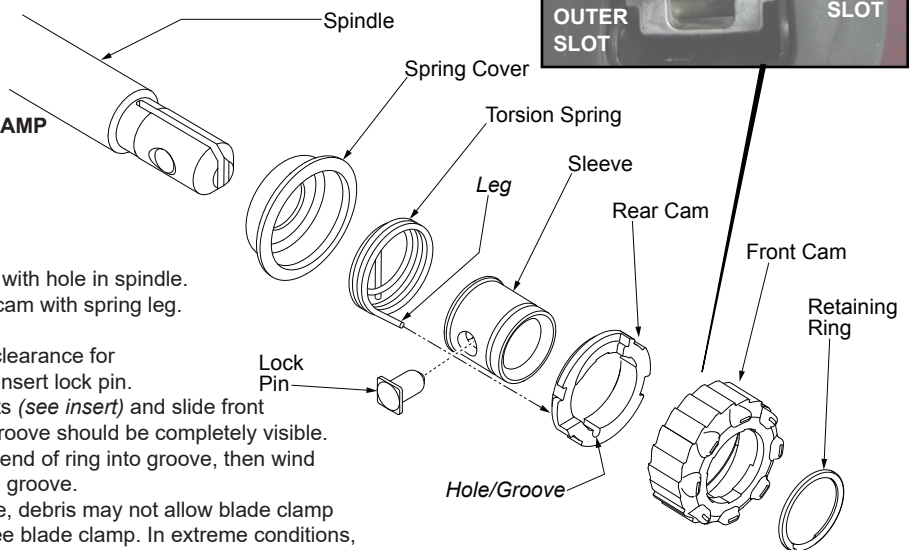

WIRING INSTRUCTIONS

TITLE

SAWZALL

BULLETIN

MILWAUKEE ELECTRIC TOOL CORP. 13135 WEST LISBON RD. BROOKFIELD, WIS.

DATE

● = WIRE TRAPS or GUIDES

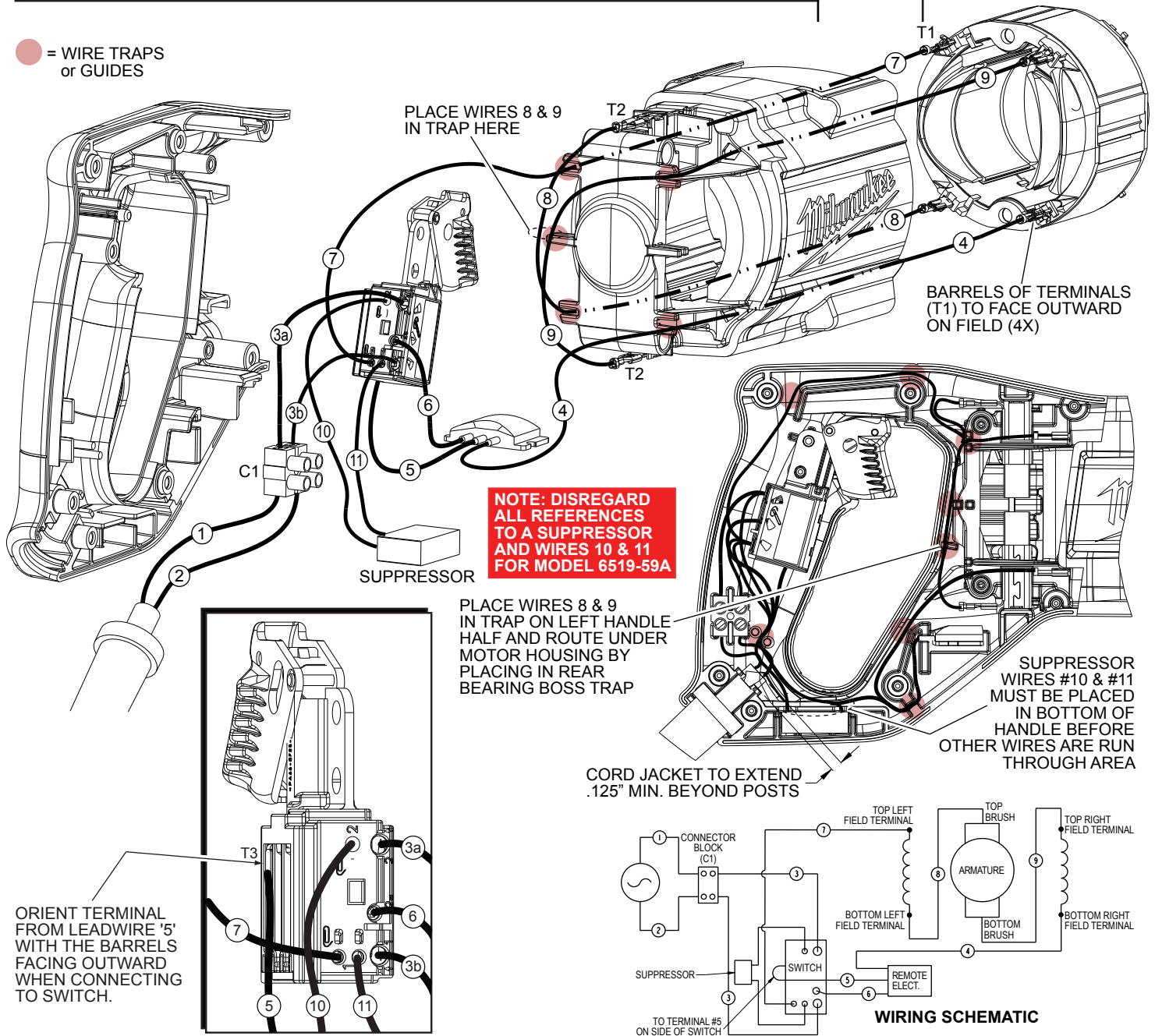

WIRING SPECIFICATIONS

Wire No.	Wire Color	Origin or Gauge	Length	Terminals, Connectors and 1 or 2 End Wire Preparation
1	Brown	Cordset	1.5"	Strip .187" for connector block (C1) opposite black wire #3a.
2	Blue	Cordset	1.5"	Strip .187" for connector block (C1) opposite black wire #3b.
3a	Black	23-94-0100	----	Insert tinned end to '2↑' on switch. Connect stripped end to connector block (C1) opposite brown cord wire #1.
3b	Black	23-94-0100	----	Insert tinned end to '1↑' on switch. Connect stripped end to connector block (C1) opposite blue cord wire #2.
4	Black	Remote Mod.	----	Connect terminal (T1) to lower right field terminal.
5	Black	Remote Mod.	----	Connect terminal (T3) to '5' on right side of switch.
6	Black	Remote Mod.	----	Connect tinned end to '2a' on switch.
7	White	23-94-0550	----	Connect tinned end to '1' on switch. Connect (T1) to upper left field terminal.
8	White	23-94-0540	----	Connect (T2) to upper brush terminal and (T1) to lower left field terminal.
9	Black	23-94-0530	----	Connect (T2) to lower brush terminal and (T1) to upper right field terminal.

NOTE:
All leads must be held to ± 1/8".
All lead lengths are before stripping.

TERMINAL DESCRIPTION

Code	Part No.	Qty.
T1	23-94-1060	4
T2	23-94-0017	2
T3	23-94-0010	1

CONNECTOR DESCRIPTION

Code	Part No.	Qty.
C1	22-56-0451	1