

SERVICE PARTS LIST

BULLETIN NO.
55-40-5100

SPECIFY CATALOG NO. AND SERIAL NO. WHEN ORDERING PARTS		REVISED BULLETIN	DATE
TRIGGER SPEED CONTROL SAWZALL			Oct. '95
CATALOG NO. 6518-4	STARTING SERIAL NO. 859A	WIRING INSTRUCTION 58-03-1356	

EXAMPLE:
Component Parts (Small #)
Are Included When Ordering
The Assembly (Large #).

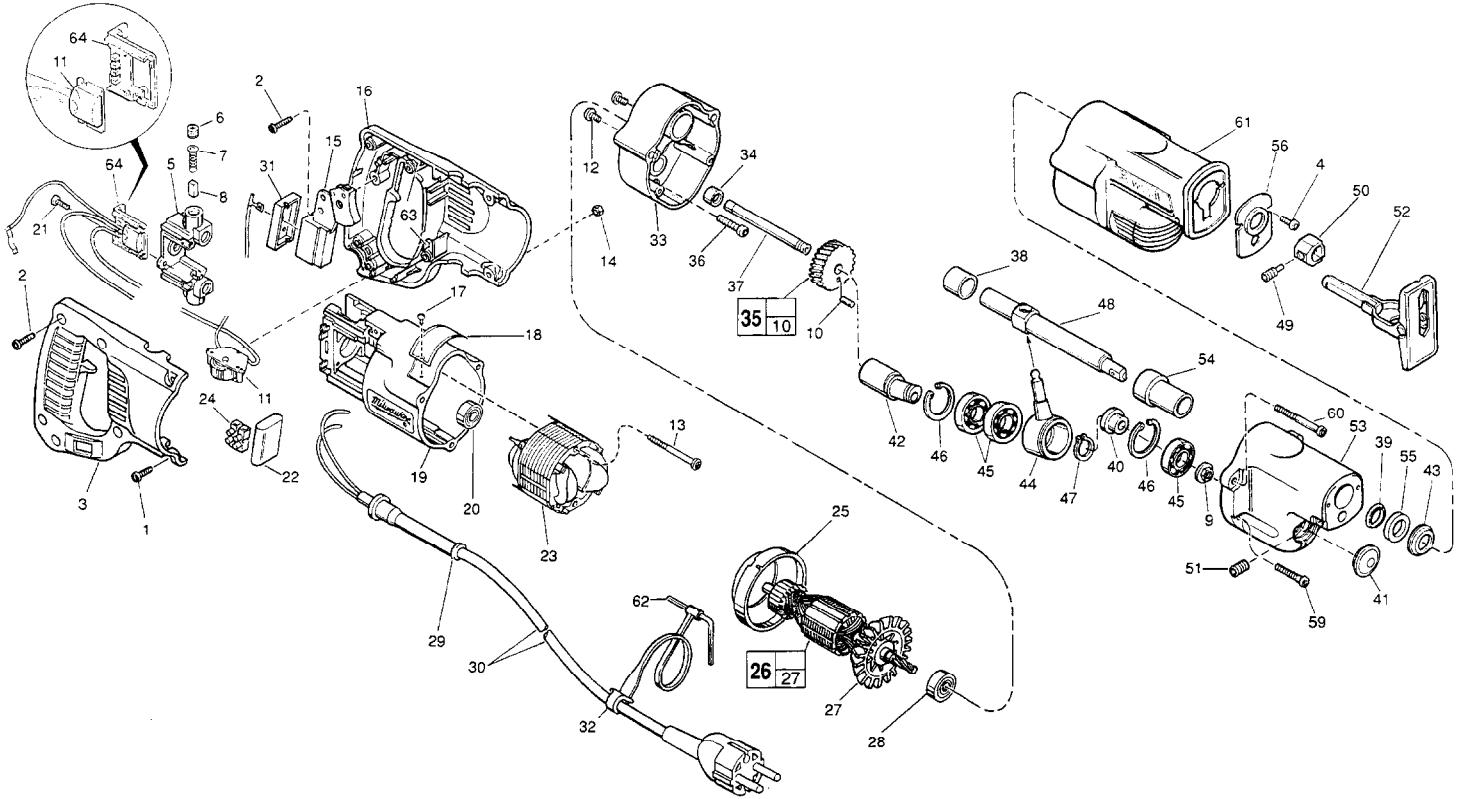

FIG.	PART NO.	DESCRIPTION OF PART	NO. REQ.	FIG.	PART NO.	DESCRIPTION OF PART	NO. REQ.
1	06-82-2390	8-32 x 1-1/4" Slotted Pan Hd. T-20	(2)	36	05-88-8307	K50 x 22mm Pan Hd. PT T-20	(1)
2	06-82-7270	8-16 x 5/8" Pan Hd. Plastite T-20	(6)	37	42-12-0180	Axle-Wobble Shaft	(1)
3	31-44-1651	Right Handle Half	(1)	38	42-24-0620	Rear Spindle Bearing	(1)
4	06-95-0075	6-32 x 3/8" Truss Hd. Tapite Screw	(2)	39	45-06-0475	Poly-Pak Seal	(1)
5	22-22-1380	Brush Holder Assembly	(1)	40	45-36-1450	Spacer	(1)
6	23-44-0190	Brush Retaining Cap	(2)	41	42-52-0380	Bearing Cap	(1)
7	23-52-0160	Brush Spring	(2)	42	36-92-0740	Wobble Shaft	(1)
8	22-16-0375	Carbon Brush	(2)	43	44-86-0595	Seal Cup	(1)
9	06-55-3790	5/16-24 Spinlock Hex Nut	(1)	44	30-72-0111	Wobble Plate	(1)
10	06-65-0606	3/16" x 1/2" Drivelok Pin	(1)	45	02-04-1510	Ball Bearing	(3)
11	14-20-3030	Dial Assembly	(1)	46	34-80-2600	Internal Retaining Ring	(2)
12	06-82-7252	8-32 x 3/8" Pan Hd. Tapite T-20	(2)	47	34-60-1315	External Retaining Ring	(1)
13	06-82-7410	8-16 x 1-7/8" Pan Hd. Slot. Plastite T-20	(2)	48	38-50-6035	Reciprocating Spindle	(1)
14	06-55-0835	8-32 Hex Nut	(2)	49	06-83-2970	Blade Clamp Screw	(1)
15	23-66-1975	Switch	(1)	50	42-68-0675	Blade Clamp	(1)
16	14-34-0423	Left Handle Half Assembly	(1)	51	06-83-3150	5/16-18 x 1/2" Hex Socket Hd. Set Screw	(1)
17	06-72-1720	Nameplate Rivet	(2)	52	45-16-0615	Pivot Shoe Assembly	(1)
18	12-99-0942	Service Nameplate	(1)	53	28-14-2180	Gear Case	(1)
19	31-50-0020	Motor Housing	(1)	54	42-24-0615	Forward Spindle Bearing	(1)
20	02-04-0845	Ball Bearing	(1)	55	45-06-0500	Felt Seal	(1)
21	06-82-7240	6-19-1/2" Pan Hd. Slotted Plastite T-15	(2)	56	44-86-0590	Seal Retainer	(1)
22	22-33-0510	Suppressor Assembly	(1)	59	06-82-5346	8-32 x 3/4" Pan Hd. Tapite T-20	(2)
23	18-32-0235	230 V. Field	(1)	60	05-88-8301	K50 x 60mm Pan Hd. PT T-20	(2)
24	22-56-0625	Terminal Block	(1)	61	45-12-0510	Gear Case Insulator	(1)
25	31-05-0050	Baffle	(1)	62	49-96-0070	5/32" Socket Wrench	(1)
26	16-34-0440	230 V. Armature	(1)	63	14-46-1001	Foam Slug Kit (10 Slugs)	(2)
27	22-84-0531	Fan Assembly	(1)	64	43-72-0175	Heat Sink Holder	(1)
28	02-04-0911	Ball Bearing	(1)				
29	44-76-0210	Cord Protector	(1)				
30	22-64-4525	Cord Set	(1)				
31	45-12-0470	Dust Shield	(1)				
32	48-66-4080	Key Holder	(1)				
33	28-28-2080	Diaphragm	(1)				
34	02-50-2150	Needle Bearing	(1)				
35	32-40-2218	Intermediate Gear Assembly	(1)				

**SEE REVERSE SIDE FOR
IMPORTANT SERVICE NOTES**

MILWAUKEE ELECTRIC TOOL CORPORATION
13135 W. LISBON RD., BROOKFIELD, WI 53005

FIG. LUBRICATION

- 33 Place 3/4 oz. of type "L" grease, No. 49-08-4175, in diaphragm cavity near needle bearing.
- 53 Place 2-3/4 oz. of type "L" grease, No. 49-08-4175, in mechanism cavity of gear case.
- 55 Saturate with bushing oil before assembly.

FIG. NOTES

- 9,10,35,37 Axle should extend .285 min. beyond intermediate gear after seating torque to spinlock hex nut (not shown) is applied.

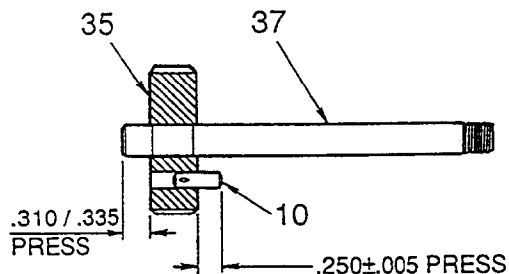

Pin is to be pressed into gear as shown.

- 20 Seal side faces commutator.
- 20,28,45 Press bearings to shaft shoulders.
- 33,38 Press rear spindle bearing flush to .030 below bearing boss of diaphragm.
- 34 Press bearing flush ($\pm .005$) to diaphragm surface.
- 39 O-ring of seal towards rear of tool.
- 45,46 Retaining rings are to be installed with the beveled side away from the bearings.
- 53,54 Press forward spindle bearing flush to .030 below bearing boss of gear case.