



SERVICE PARTS LIST

BULLETIN NO.
54-40-0727

SPECIFY CATALOG NO. AND SERIAL NO. WHEN ORDERING PARTS		REVISED BULLETIN 54-40-0726	DATE Jan. '97
TRIGGER SPEED CONTROL SAWZALL			
CATALOG NO.	6518	STARTING SERIAL NO.	859C
		WIRING INSTRUCTION 58-01-0781	

EXAMPLE:
Component Parts (Small #)
Are Included When Ordering
The Assembly (Large #).

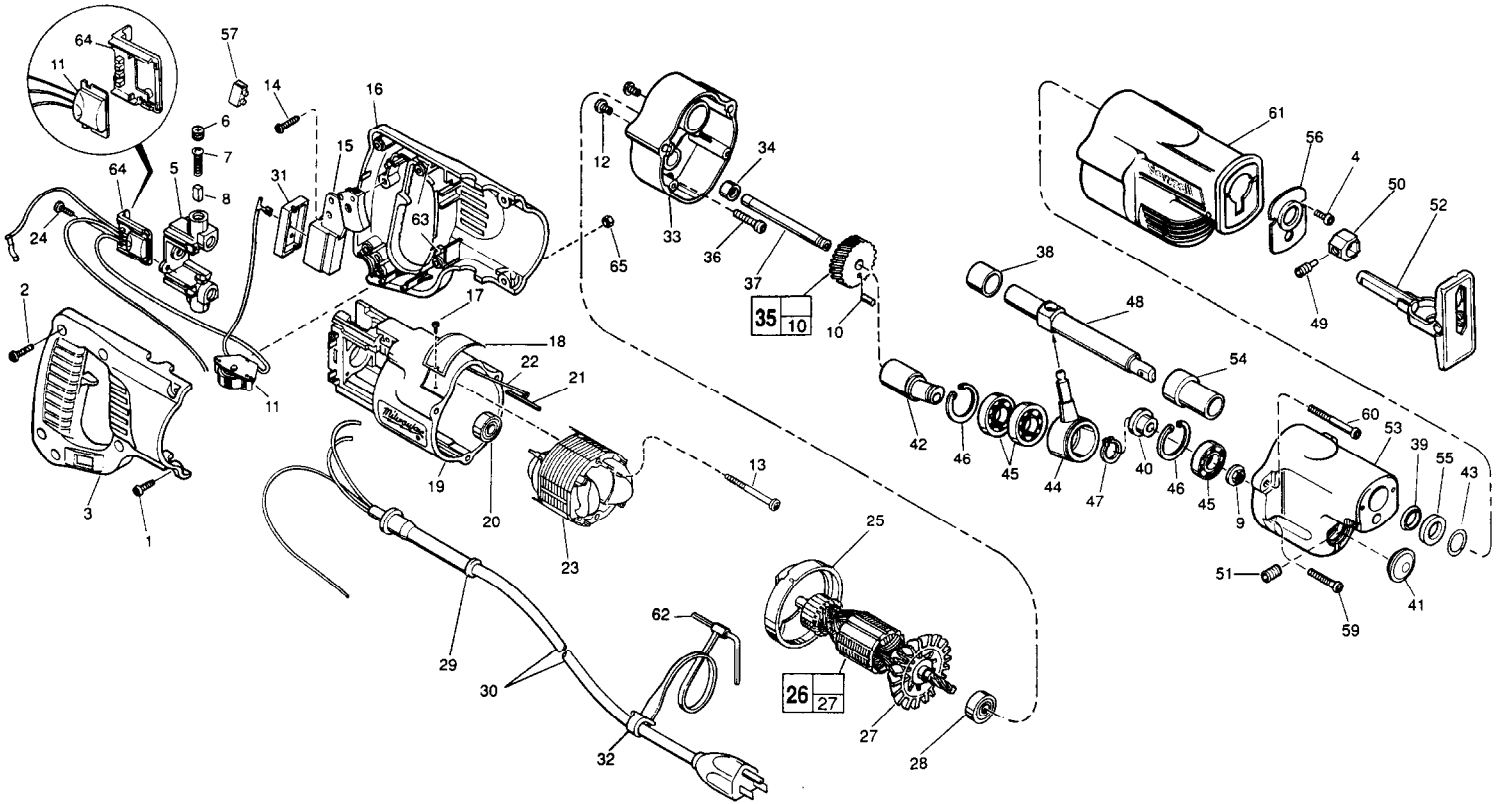

FIG.	PART NO.	DESCRIPTION OF PART	NO. REQ.
★ 1	06-82-2390	8-32 x 1-1/4" Slotted Pan Hd. T-20	(2)
2	06-82-7270	8-16 x 5/8" Pan Hd. Plastite T-20	(5)
3	31-44-1651	Right Handle Half	(1)
★ 4	06-95-0075	6-32 x 3/8" Truss Hd. Taptite T-10 Screw	(2)
5	22-22-1380	Brush Holder Assembly	(1)
6	23-44-0190	Brush Retaining Cap	(2)
7	23-52-0160	Brush Spring	(2)
8	22-16-0275	Carbon Brush	(2)
9	06-55-3790	5/16-24 Spinlock Hex Nut	(1)
10	06-65-0606	3/16" x 1/2" Drivelok Pin	(1)
11	14-20-3020	Dial Assembly	(1)
12	06-82-7252	8-32 x 3/8" Pan Hd. Taptite T-20	(2)
★ 13	06-82-7410	8-16 x 1-7/8" Pan Hd. Slit. Plastite T-20	(2)
14	06-82-7270	8-16 x 5/8" Pan Hd. Plastite T-20	(1)
15	23-66-1490	Switch	(1)
16	31-44-1656	Left Handle Half	(1)
17	06-72-1720	Nameplate Rivet	(2)
18	12-99-1730	Service Nameplate	(1)
★ 19	31-50-0020	Motor Housing	(1)
20	02-04-0845	Ball Bearing	(1)
★ 21	44-60-0530	Ground Pin	(1)
★ 22	23-94-6100	Ground Wire Assembly	(1)
23	18-31-0600	120 V. Field	(1)
★ 24	06-82-7240	6-19 x 1/2" Pan Hd. Slot. Plastite T-15	(2)
★ 25	31-05-0055	Baffle	(1)
26	16-30-0535	120 V. Armature	(1)
27	22-84-0531	Fan Assembly	(1)
28	02-04-0911	Ball Bearing	(1)
29	44-76-0210	Cord Protector	(1)
30	22-64-3190	Cord Set	(1)
31	45-12-0470	Dust Shield	(1)
32	48-66-4080	Key Holder	(1)
33	28-28-2080	Diaphragm	(1)
34	02-50-2150	Needle Bearing	(1)
35	32-40-2218	Intermediate Gear Assembly	(1)

FIG.	PART NO.	DESCRIPTION OF PART	NO. REQ.
★ 36	05-88-8307	K50 x 22mm Pan Hd. PT T-20	(1)
37	42-12-0180	Axle-Wobble Shaft	(1)
38	42-24-0620	Rear Spindle Bearing	(1)
39	45-06-0475	Poly-Pak Seal	(1)
40	45-36-1450	Spacer	(1)
41	42-52-0380	Bearing Cap	(1)
42	36-92-0740	Wobble Shaft	(1)
★ 43	45-88-8576	Washer	(1)
44	30-72-0111	Wobble Plate	(1)
45	02-04-1510	Ball Bearing	(3)
46	34-80-2600	Internal Retaining Ring	(2)
47	34-60-1315	External Retaining Ring	(1)
48	38-50-6035	Reciprocating Spindle	(1)
★ 49	06-83-2971	Blade Clamp Screw	(1)
★ 50	42-68-0676	Blade Clamp	(1)
51	06-83-3150	5/16-18 x 1/2" Hex Socket Hd. Set Screw	(1)
52	45-16-0615	Pivot Shoe Assembly	(1)
53	28-14-2180	Gear Case	(1)
54	42-24-0615	Forward Spindle Bearing	(1)
55	45-06-0500	Felt Seal	(1)
★ 56	44-86-0615	Seal Retainer	(1)
★ 57	22-56-0456	Terminal Block	(1)
59	06-82-5346	8-32 x 3/4" Pan Hd. Taptite T-20	(2)
★ 60	05-88-8301	K50 x 60mm Pan Hd. PT T-20	(2)
61	45-12-0510	Gear Case Insulator	(1)
62	49-96-0070	5/32" Socket Wrench	(1)
63	14-46-1001	Foam Slug Kit (10 Slugs)	(2)
★ 64	43-72-0176	Heat Sink Holder	(1)
★ 65	06-55-0835	8-32 Hex Nut	(2)

**SEE REVERSE SIDE FOR
IMPORTANT SERVICE NOTES**

MILWAUKEE ELECTRIC TOOL CORPORATION
13135 W. LISBON RD., BROOKFIELD, WI 53005