



# SERVICE PARTS LIST

BULLETIN NO.  
54-40-0701

SPECIFY CATALOG NO. AND SERIAL NO. WHEN ORDERING PARTS		REVISED BULLETIN	DATE
TRIGGER SPEED CONTROL SAWZALL		54-40-0700	Oct. '95
CATALOG NO.	6517	WIRING INSTRUCTION	
STARTING SERIAL NO.	858B	58-01-0780	

EXAMPLE:  
 Component Parts (Small #)  
 Are Included When Ordering  
 The Assembly (Large #).

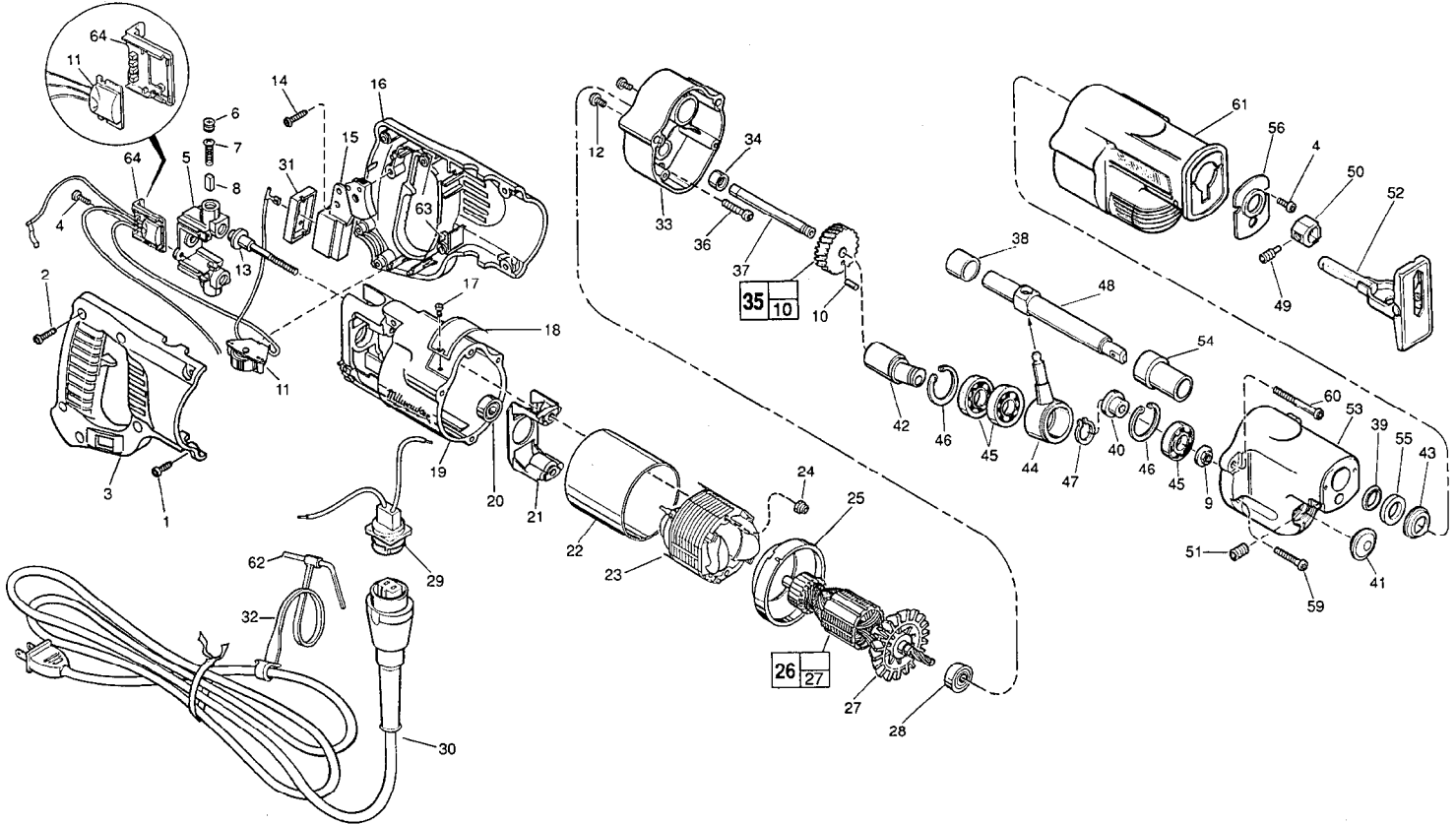

FIG.	PART NO.	DESCRIPTION OF PART	NO. REQ.	FIG.	PART NO.	DESCRIPTION OF PART	NO. REQ.
1	06-82-5316	8-32 x 1/2" Slot Pan Hd. T-20	(4)	36	06-82-5320	8-32 x 5/8" Pan Hd. Slit. Taptite T-20	(1)
2	06-82-7270	8-16 x 5/8" Pan Hd. Plastite T-20	(5)	37	42-12-0180	Axle-Wobble Shaft	(1)
3	31-44-1661	Right Handle Half	(1)	38	42-24-0620	Rear Spindle Bearing	(1)
4	06-95-0075	6-32 x 3/8" Truss Hd. Taptite Screw	(4)	39	45-06-0475	Poly-Pak Seal	(1)
5	22-22-1380	Brush Holder Assembly	(1)	40	45-36-1450	Spacer	(1)
6	23-44-0190	Brush Retaining Cap	(2)	41	42-52-0380	Bearing Cap	(1)
7	23-52-0160	Brush Spring	(2)	42	36-92-0740	Wobble Shaft	(1)
8	22-16-0275	Carbon Brush	(2)	43	44-86-0595	Seal Cup	(1)
9	06-55-3790	5/16-24 Spinlock Hex Nut	(1)	44	30-72-0111	Wobble Plate	(1)
10	06-65-0606	3/16" x 1/2" Drivelok Pin	(1)	45	02-04-1510	Ball Bearing	(3)
11	14-20-3020	Dial Assembly	(1)	46	34-80-2600	Internal Retaining Ring	(2)
12	06-82-7252	8-32 x 3/8" Pan Hd. Taptite T-20	(2)	47	34-60-1315	External Retaining Ring	(1)
13	06-81-1060	8-16 x 2-1/4 Field Bolt	(2)	48	38-50-6035	Reciprocating Spindle	(1)
14	06-82-7270	8-16 x 5/8" Pan Hd. Plastite T-20	(2)	49	06-83-2970	Blade Clamp Screw	(1)
15	23-66-1490	Switch	(1)	50	42-68-0675	Blade Clamp	(1)
16	31-44-1666	Left Handle Half	(1)	51	06-83-3150	5/16-18 x 1/2" Hex Socket Hd. Set Screw	(1)
17	06-72-1720	Nameplate Rivet	(2)	52	45-16-0615	Pivot Shoe Assembly	(1)
18	12-99-1740	Service Nameplate	(1)	53	28-14-2180	Gear Case	(1)
19	28-50-6220	Motor Housing	(1)	54	42-24-0615	Forward Spindle Bearing	(1)
20	02-04-0845	Ball Bearing	(1)	55	45-06-0500	Felt Seal	(1)
21	31-55-0190	Coil Shield	(1)	56	44-86-0590	Seal Retainer	(1)
22	23-16-0456	Field Insulator	(1)	59	06-82-5346	8-32 x 3/4" Pan Hd. Taptite T-20	(2)
23	18-31-0600	120 V. Field	(1)	60	06-82-5516	8-32 x 2-3/8" Pan Hd. Slit. Taptite T-20	(2)
24	06-57-2975	8-32 Flexlock Hex Nut	(2)	61	45-12-0510	Gear Case Insulator	(1)
25	31-05-0050	Baffle	(1)	62	49-96-0070	5/32" Socket Wrench	(1)
★ 26	16-30-0535	120 V. Armature	(1)	63	14-46-1001	Foam Slug Kit (10 Slugs)	(2)
27	22-84-0531	Fan Assembly	(1)	64	43-72-0175	Heat Sink Holder	(1)
28	02-04-0911	Ball Bearing	(1)				
29	22-56-0690	Blade Housing Assembly	(1)				
30	48-76-5010	Quik-Lok Cord Set	(1)				
31	45-12-0470	Dust Shield	(1)				
32	48-66-4080	Key Holder	(1)				
33	28-28-2080	Diaphragm	(1)				
34	02-50-2150	Needle Bearing	(1)				
★ 35	32-40-2218	Intermediate Gear Assembly	(1)				

**SEE REVERSE SIDE FOR  
IMPORTANT SERVICE NOTES**

MILWAUKEE ELECTRIC TOOL CORPORATION  
13135 W. LISBON RD., BROOKFIELD, WI 53005

**FIG. LUBRICATION**

- 33 Place 3/4 oz. of type "L" grease, No. 49-08-4175, in diaphragm cavity near needle bearing.
- 53 Place 2-3/4 oz. of type "L" grease, No. 49-08-4175, in mechanism cavity of gear case.
- 55 Saturate with bushing oil before assembly.

**FIG. NOTES**

- 9,10,35,37 Axle should extend .285 min. beyond intermediate gear after seating torque to spinlock hex nut (not shown) is applied.

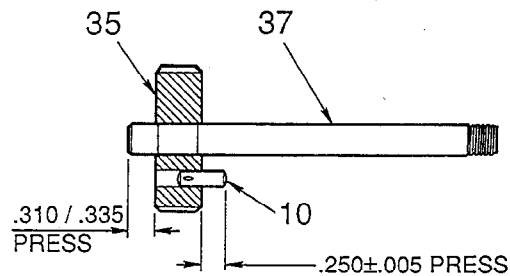

Pin is to be pressed into gear as shown.

- 20 Seal side faces commutator.
- 20,28,45 Press bearings to shaft shoulders.
- 33,38 Press rear spindle bearing flush to .030 below bearing boss of diaphragm.
- 34 Press bearing flush ( $\pm .005$ ) to diaphragm surface.
- 39 O-ring of seal towards rear of tool.
- 45,46 Retaining rings are to be installed with the beveled side away from the bearings.
- 53,54 Press forward spindle bearing flush to .030 below bearing boss of gear case.