



SERVICE PARTS LIST

BULLETIN NO.
54-40-0800

SPECIFY CATALOG NO. AND SERIAL NO. WHEN ORDERING PARTS		REVISED BULLETIN	DATE
SAW MOTOR			May 2002
CATALOG NO. 6486-20 6486-69	STARTING SERIAL NUMBER 401A	WIRING INSTRUCTION 58-01-0765	

EXAMPLE:
00 0 Component Parts (Small #)
Are Included When Ordering
The Assembly
(Large #).

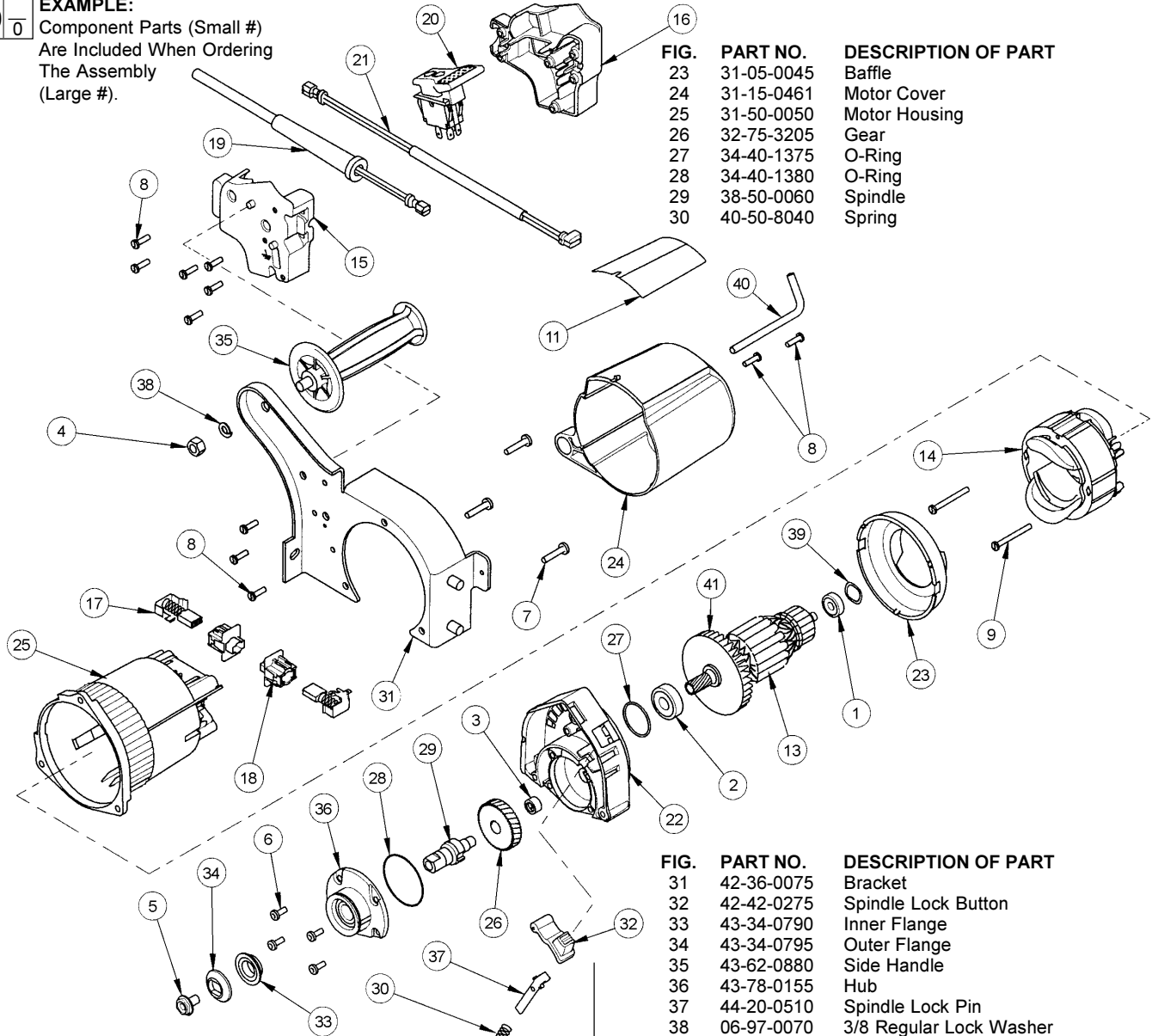

FIG.	PART NO.	DESCRIPTION OF PART	QTY.
23	31-05-0045	Baffle	(1)
24	31-15-0461	Motor Cover	(1)
25	31-50-0050	Motor Housing	(1)
26	32-75-3205	Gear	(1)
27	34-40-1375	O-Ring	(1)
28	34-40-1380	O-Ring	(1)
29	38-50-0060	Spindle	(1)
30	40-50-8040	Spring	(1)

FIG.	PART NO.	DESCRIPTION OF PART	QTY.
31	42-36-0075	Bracket	(1)
32	42-42-0275	Spindle Lock Button	(1)
33	43-34-0790	Inner Flange	(1)
34	43-34-0795	Outer Flange	(1)
35	43-62-0880	Side Handle	(1)
36	43-78-0155	Hub	(1)
37	44-20-0510	Spindle Lock Pin	(1)
38	06-97-0070	3/8 Regular Lock Washer	(1)
39	45-88-0577	Wave Spring Washer	(1)
40	49-96-0345	Hex Key	(1)
41	22-84-0085	Fan	(1)

FIG.	PART NO.	DESCRIPTION OF PART	QTY.
1	02-04-0850	Ball Bearing	(1)
2	02-04-1850	Ball Bearing	(1)
3	02-50-2423	Needle Bearing	(1)
4	06-55-2500	Hex Nut	(1)
5	06-75-0035	5/16-18 x 9/16 Screw	(1)
6	06-82-5314	10-24 x .5 Pan Hd. Tapt. T-25	(4)
7	06-82-5376	12-24 x 1.00 Pan Hd. Tapt. T-27	(3)
8	06-82-7270	8-16 x .625 Pan Hd. Slit. Plast. T-20	(11)
9	06-82-7395	8-16 x 1.75 Pan Hd. Slit. Plast. T-20	(2)
11	12-20-0196	Service Nameplate Kit	(1)
13	16-70-0055	Armature	(1)
14	18-70-1045	Field	(1)
15	22-12-0030	Switch Box	(1)
16	22-12-0035	Switch Cover	(1)
17	22-18-0075	Brush Assembly	(2)
18	22-22-0030	Brush Tube Assembly	(2)
19	22-64-0255	Cord Assembly	(1)
20	23-66-0125	Switch Assembly	(1)
21	23-94-0090	Lead Assembly	(1)
22	28-14-0130	Gearcase	(1)

FIG. LUBRICATION:
22 Apply .320 - .360 oz. "Y" Grease, No. 49-08-5270, to gear bore of upper guard gearcase. The grease should be directed toward the pinion end of the armature.

22,27 Apply a light film of vegetable oil to the bearing bore and o-ring in the gearcase before assembling the armature/bearing.

FIG. NOTES:
1 Orient the ball bearing such that the seal faces the commutator.
3 Orient the needle bearing so the text is facing the gear. Press the bearing .015 subflush to the gear cavity wall.