



# SERVICE PARTS LIST

**BULLETIN NO.**  
**54-40-1126**

SPECIFY CATALOG NO. AND SERIAL NO. WHEN ORDERING PARTS		REVISED BULLETIN 54-40-1125	DATE Jan. '95
<b>10-1/4" CIRCULAR SAW</b>			
CATALOG NO.	6460	STARTING SERIAL NO.	607B
		WIRING INSTRUCTION <b>58-01-0750</b>	

**EXAMPLE:**  
Component Parts  
(Small #)  
Are Included When  
Ordering  
The Assembly  
(Large #).

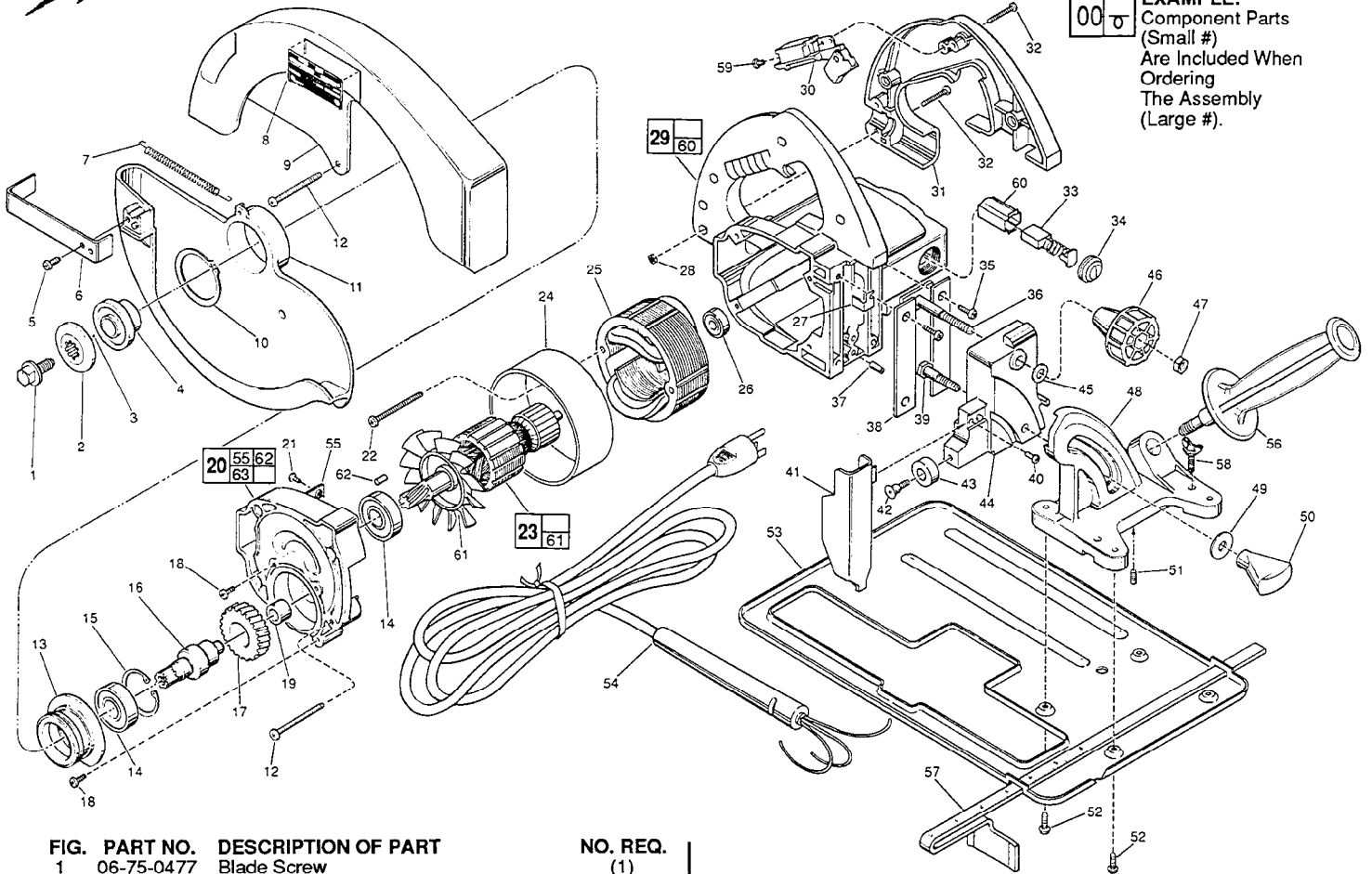

FIG.	PART NO.	DESCRIPTION OF PART	NO. REQ.
1	06-75-0477	Blade Screw	(1)
2	45-88-7420	Spindle Blade Retaining Washer	(1)
3		10-1/4" Blade (Select From Catalog)	(1)
4	43-34-0260	Spindle Flange	(1)
5	06-82-5316	8-32 x 1/2" Pan Hd. Slit. Taptite T-20	(1)
6	43-62-0705	Lower Guard Handle	(1)
★ 7	40-50-7751	Lower Guard Spring	(1)
8	12-20-0620	Service Nameplate Kit	(1)
9	25-41-0670	Upper Guard	(1)
10	34-60-2210	Retaining Ring - External	(1)
★ 11	28-41-0661	Lower Guard	(1)
12	06-82-7382	8-16 x 1-5/8" Pan Hd. Plastite T-20	(4)
13	43-78-0280	Lower Guard Hub	(1)
14	02-04-1748	Ball Bearing	(2)
15	34-80-2960	Retaining Ring - Internal	(1)
16	38-50-5175	Gear Spindle	(1)
17	32-75-2790	Spindle Gear	(1)
18	06-82-7252	8-32 x 3/8" Pan Hd. Slit. Taptite T-20	(4)
19	02-50-2423	Needle Bearing	(1)
20	14-30-0290	Gear Case Assembly	(1)
21	06-81-8820	Ground Screw	(1)
22	06-82-7453	8-16 x 2-1/4" Pan Hd. Plastite T-20	(2)
23	16-70-0131	120 V. Armature	(1)
24	23-16-0691	Field Insulating Sleeve	(1)
25	18-70-0095	120 V. Field	(1)
26	02-04-0850	Ball Bearing	(1)
27	42-70-0200	Ground Clip	(1)
28	06-55-0835	8-32 Hex Nut	(5)
29	31-50-0153	Motor Housing Assembly	(1)
30	23-66-1810	Switch	(1)
31	31-44-0480	L.H. Handle	(1)
32	06-82-2362	8-32 x 1" Pan Hd. Slit. T-20	(5)
33	22-18-0147	Carbon Brush Assembly	(2)
34	23-44-0160	Brush Retaining Screw	(2)
35	06-82-7270	8-16 x 5/8 Pan Hd Slit. Plastite T-20	(4)
36	45-58-0260	Vertical Adjusting Stud	(1)
37	06-65-1580	3/16 x 1/2" Lg. Roll Pin	(1)
38	44-66-5321	Vertical Bracket Plate	(2)

FIG.	PART NO.	DESCRIPTION OF PART	NO. REQ.
39	45-58-0270	Angular Adjusting Stud	(1)
40	06-82-7252	8-32 x 3/8" Pan Hd. Slit. Taptite T-20	(1)
41	43-54-0360	Front Blade Guard Assembly	(1)
42	45-04-0485	Guard Bumper Screw	(1)
★ 43	42-38-0076	Rubber Bumper	(1)
44	25-10-0644	Vertical Adjusting Bracket	(1)
45	45-88-0660	Angular Adjusting Washer	(1)
46	43-98-0190	Vertical Adjusting Knob	(1)
47	06-55-1985	5/16-18 Hex Nut	(1)
48	25-10-0640	Angular Adjusting Bracket	(1)
49	45-88-0650	Angular Adjusting Washer	(1)
50	43-98-0240	Adjusting Knob	(1)
51	06-83-0801	8-32 x 3/8" Hdls. Set Screw	(1)
52	06-95-0212	8-32 x 1/2" Pan Hd. Phil. Dr. Screw	(4)
53	45-16-0385	Saw Shoe	(1)
54	22-64-0076	Cord Set	(1)
55	42-36-1120	Ground Screw Bracket	(1)
56	43-62-0885	Side Handle	(1)
57	49-02-0080	Rip Fence	(1)
58	06-88-0110	1/4-20 x 3/4" Wing Screw	(2)
59	05-78-0305	Switch Screw	(4)
60	22-20-0350	Brush Insert	(2)
61	22-84-0655	Fan Assembly	(1)
62	45-30-0110	Ball Bearing Retaining Slug	(1)
63	06-82-7252	8-32 x 3/8" Pan Hd. Slit. Tapt. T-20 (Not Shown)	(1)
	49-96-6200	9/16" Wrench	(1)
	10-98-6131	Warning Label	(1)

**FIG. LUBRICATION**  
20 1/2 Oz. Type "O" Grease, No. 49-08-4200.  
**FIG. NOTES**  
51 Apply "Blue" Loctite, Type 242.

**MILWAUKEE ELECTRIC TOOL CORPORATION**  
13135 W. LISBON RD., BROOKFIELD, WI 53005