



SERVICE PARTS LIST

BULLETIN NO.
54-40-0140

SPECIFY CATALOG NO. AND SERIAL NO. WHEN ORDERING PARTS		REVISED BULLETIN	DATE
D.I. 8-1/4" CIRCULAR SAW			March '80
CATALOG NO. 6407	STARTING SERIAL NO. 633-1001	WIRING INSTRUCTION 58-01-0751	

FOR CAT. NO. 6407-2 (240V) TOOL USE:

- 16-76-0035 ARMATURE
- 18-76-0030 FIELD
- 22-64-4050 CORD SET
- 23-66-0508 SWITCH
- 58-01-0750 WIRING INST.

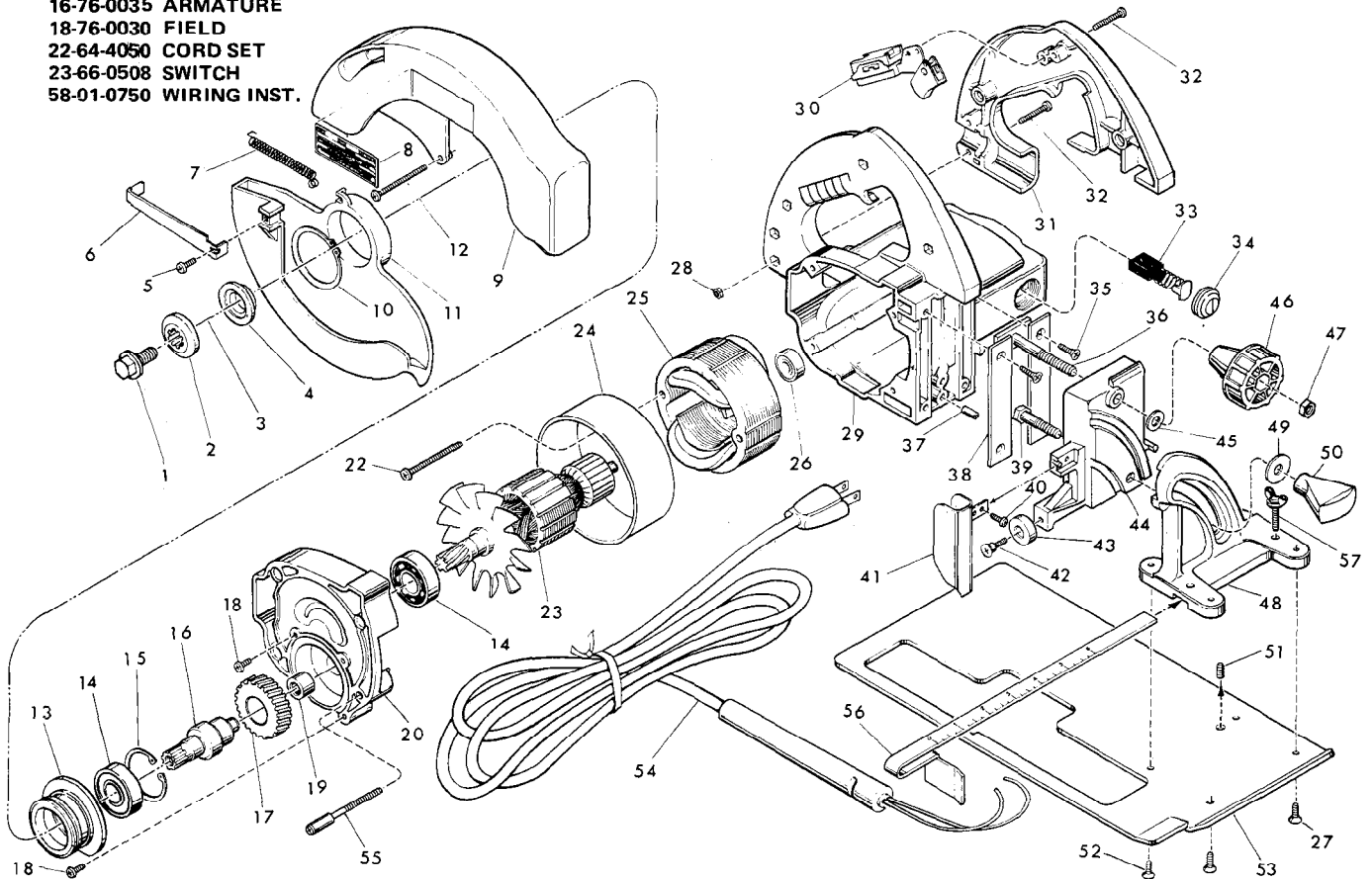

FIG.	PART NO.	DESCRIPTION OF PART	NO. REQ.	FIG.	PART NO.	DESCRIPTION OF PART	NO. REQ.
1	06-75-0474	Blade Screw	(1)	30	23-66-0505	Switch	(1)
2	45-88-0286	Spindle Blade Retaining Washer	(1)	31	31-44-0480	L. H. Handle	(1)
3		8-1/4 Blade (Select From Catalog)	(1)	32	06-81-0472	8-32x1 Pan Hd. Screw	(5)
4	43-34-0251	Spindle Flange	(1)	33	22-18-0550	Carbon Brush Assembly	(2)
5	06-95-0210	8-32x3/8 Pan Hd. Screw	(1)	34	23-44-0160	Brush Retaining Screw	(2)
6	43-62-0660	Lower Guard Handle	(1)	35	06-95-3240	8-32x3/4 Fl. Hd. Screw	(4)
7	40-50-3750	Lower Guard Spring	(1)	36	45-58-0250	Vertical Adjusting Stud	(1)
8	12-99-0190	Nameplate Blank	(1)	37	06-65-1580	3/16x1/2 Lg. Roll Pin	(1)
9	26-41-0570	Upper Guard	(1)	38	44-66-0650	Vertical Bracket Plate	(2)
10	34-60-2210	Retaining Ring-External	(1)	39	45-58-0240	Angular Adjusting Stud	(1)
11	26-41-0560	Lower Guard	(1)	40	06-95-0210	8-32x3/8 Pan Hd. Screw	(1)
12	06-95-0260	8-32x1-5/8 Pan Hd. Screw	(3)	41	43-54-0330	Front Blade Guard Assembly	(1)
13	43-78-0250	Lower Guard Hub	(1)	42	45-04-0485	Guard Bumper Screw	(1)
14	02-04-1746	Ball Bearing	(2)	43	42-38-0075	Rubber Bumper	(1)
15	34-80-2960	Retaining Ring-Internal	(1)	44	28-10-0630	Vertical Adjusting Bracket	(1)
16	38-50-1075	Gear Spindle	(1)	45	45-88-0660	Angular Adjusting Washer	(1)
17	32-75-2770	Spindle Gear	(1)	46	43-98-0190	Vertical Adjusting Knob	(1)
18	06-95-0211	8-32x3/8 Pan Hd. Screw	(4)	47	06-55-1985	5/16-18 Hex Nut	(1)
19	02-50-2423	Needle Bearing	(1)	48	28-10-0600	Angular Adjusting Bracket	(1)
20	26-14-0900	Gear Case	(1)	49	45-88-0650	Angular Adjusting Washer	(1)
21	12-98-7082	Caution Plate (Not Shown)	(1)	50	43-98-0110	Depth Adjusting Knob	(1)
22	06-95-0370	10-24x1-3/4 Pan Hd. Screw	(2)	51	06-83-0800	8-32x3/8 Hdls. Set Screw	(1)
23	16-70-0035	120V. Armature	(1)	52	06-95-3241	8-32x1/2 Fl. Hd. Screw	(1)
24	23-16-0691	Field Insulating Sleeve	(1)	53	45-16-0330	Saw Shoe	(1)
25	18-70-0035	120V. Field	(1)	54	22-64-0780	Cord Set	(1)
26	02-04-0850	Ball Bearing	(1)	55	06-95-0267	Shoulder Screw	(1)
27	06-95-3250	8-32x5/8 Flat Hd. Phil. Dr. Screw	(3)	56	49-02-0050	Rip Fence (Optional)	(1)
28	06-55-0825	8-32 Hex Nut	(5)	57	06-88-0100	Wing Screw (Optional)	(2)
29	31-50-0150	Motor Housing Assembly (Includes Two 22-20-0350 Brush Inserts)	(1)	58	49-96-6200	9/16" Wrench (Not Shown)	(1)