



# SERVICE PARTS LIST

**BULLETIN NO.**  
**54-40-1157**

SPECIFY CATALOG NO. AND SERIAL NO. WHEN ORDERING PARTS		REVISED BULLETIN 54-40-1156	DATE July '92
<b>8-1/4" CIRCULAR SAW</b>			
CATALOG NO.	6405	SERIAL NUMBER	552-112885
		WIRING INSTRUCTION <b>58-01-1251</b>	

**EXAMPLE:**  
Component Parts ( Small #) Are Included  
When Ordering The Assembly (Large #).



FIG.	PART NO.	DESCRIPTION OF PART	QTY.
1	02-04-0850	Ball Bearing	(1)
2	02-04-2650	Ball Bearing	(2)
3	02-04-2775	Ball Bearing	(1)
4	02-50-2423	Needle Bearing	(1)
5	06-55-0835	8-32 Hex Nut	(4)
6	06-55-1985	5/16-18 Hex Nut	(1)
7	06-65-1535	1/8 x 3/4" Roll Pin	(1)
★ 8	06-75-0477	3/8-24 x 11/16" Blade Screw	(1)
9	06-82-2362	8-32 x 1" Slot. Pan Hd. T-20	(1)
10	06-82-5316	8-32 x 1/2" Slot. Pan Hd. Tapt. T-20	(1)
11	06-82-7252	8-32 x 3/8" Slot. Pan Hd. Tapt. T-20	(2)
12	06-82-7270	8-16 x 5/8" Slot. Pan Hd. Plast. T-20	(4)
13	06-82-7453	8-16 x 2-1/4" Slot. Pan Hd. Plast. T-20	(1)
14	06-83-3620	4-40 x 1/2" Socket Set Screw	(4)
15	06-95-0335	1/4-20 x 1/2" Fil. Hd. Screw	(2)

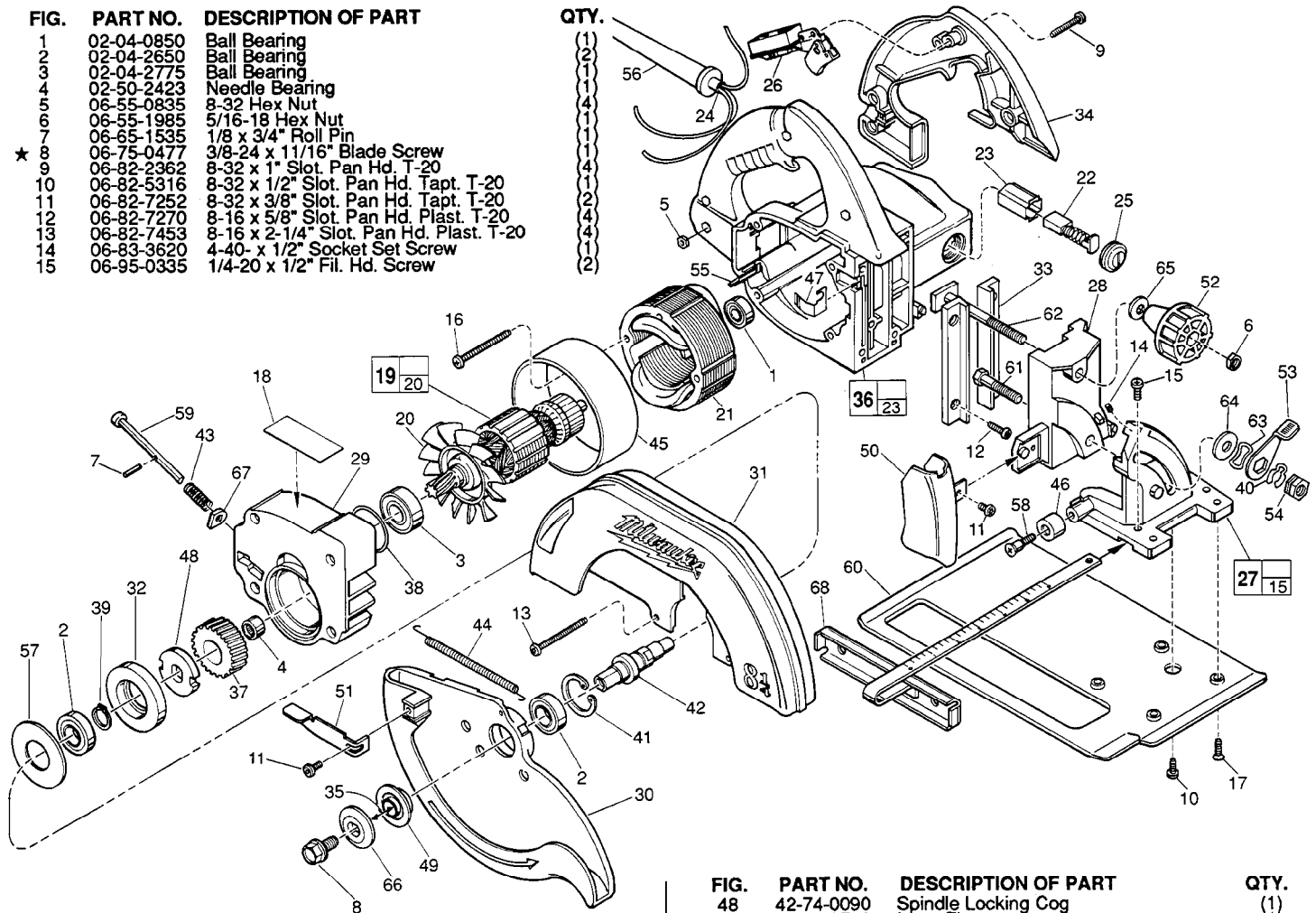

FIG.	PART NO.	DESCRIPTION OF PART	QTY.
★ 16	06-95-7395	8-16 x 1-3/4" Pan Hd. #2 Phil. Swag Form	(2)
17	06-95-3250	8-32 x 5/8" Fil Hd. #2 Phil. Tapt. Screw	(4)
18	12-99-0357	Nameplate Blank	(1)
19	16-70-0430	120 V Armature	(1)
20	22-84-0655	Fan Assembly	(1)
★ 21	18-70-0032	120 V Field	(1)
22	22-18-0550	Carbon Brush Assembly	(2)
★ 23	22-20-0820	Brush Insert	(2)
24	22-64-0790	Cord Set	(1)
25	23-44-0160	Brush Retaining Screw	(2)
26	23-66-0167	Switch	(1)
27	28-10-0791	Angular Adjusting Bracket	(1)
★ 28	25-10-0810	Vertical Adjusting Bracket	(1)
29	28-14-2170	Gear Case	(1)
30	28-41-0930	Lower Guard	(1)
31	25-41-0939	Upper Guard	(1)
32	28-53-0280	Hub	(1)
33	28-72-0049	Vertical Adjusting Plate	(2)
★ 34	31-44-1421	Left Handle Half	(1)
35		8-1/4" Blade (Select from Catalog)	(1)
36	31-50-0521	Motor Housing Assembly	(1)
37	32-75-3330	Gear	(1)
38	34-40-1375	1-1/4" O-Ring	(1)
39	34-60-1200	Retaining Ring	(1)
40	34-60-2330	Klipring	(1)
41	34-80-2600	Internal Retaining Ring	(1)
42	38-50-5820	Spindle	(1)
43	40-50-8040	Spindle Lock Spring	(1)
44	40-50-8350	Lower Guard Spring	(1)
45	42-14-0310	Baffle	(1)
46	42-38-0223	Bumper	(1)
47	42-70-0230	Ground Clip	(1)

FIG.	PART NO.	DESCRIPTION OF PART	QTY.
48	42-74-0090	Spindle Locking Cog	(1)
49	43-34-0710	Inner Flange	(1)
50	43-54-0547	Front Blade Guard	(1)
51	43-62-0910	Lower Blade Handle	(1)
52	43-98-0190	Vertical Adjusting Knob	(1)
53	44-10-0200	Lever	(1)
54	44-40-0460	Adjustment Nut	(1)
55	44-60-0530	Ground Pin	(1)
56	44-76-0050	Cord Protector	(1)
57	44-86-0520	Bearing Retainer Plate	(1)
58	45-04-0505	Bumper Screw	(1)
59	45-08-0200	Spindle Lock Shaft	(1)
60	45-16-0575	Shoe	(1)
61	45-58-0270	Angular Adjusting Stud	(1)
62	45-58-0325	Vertical Adjusting Stud	(1)
63	45-88-0577	Wave Washer	(1)
64	45-88-0650	Angular Adjusting Washer	(1)
65	45-88-0660	Adjusting Washer	(1)
66	45-88-8200	Spindle Washer	(1)
67	45-88-8250	Felt Washer	(1)
	49-96-6200	9/16" Box Wrench	(1)

**FIG. 10, 11, 14, 27, 28, 33** **NOTE**  
Apply Blue Loctite, Type CV-242.  
Apply a light coat of teflon dry spray lubricant to all sliding surfaces.  
**44** Hooks of spring must be completely inserted in slots. Long hook in upper guard.  
**48** Radius on locking cog must be up against face of gear.  
**59** Flat of spindle lock shaft must face gear.

**FIG. 29** **LUBRICATION**  
1/2 Oz. Type "O" Grease, No. 49-08-4200.

**MILWAUKEE ELECTRIC TOOL CORPORATION**  
13135 W. LISBON RD., BROOKFIELD, WI 53005