



SERVICE PARTS LIST

BULLETIN NO.
54-40-0126

SPECIFY CATALOG NO. AND SERIAL NO. WHEN ORDERING PARTS		REVISED BULLETIN 54-40-0125	DATE July 92
D.I. 7-1/4" CIRCULAR SAW			
CATALOG NO. 6367	STARTING SERIAL NO. 632-34730	WIRING INSTRUCTION 58-01-0753	

EXAMPLE:
Component Parts (Small #)
Are Included When Ordering
The Assembly (Large #).



FIG.	PART NO.	DESCRIPTION OF PART	NO. REQ.
1	06-95-3241	8-32 x 1/2" Flat Hd. Form Screw	(4)
2	28-53-0260	Hub	(1)
3	02-04-1701	Ball Bearing	(1)
4	34-80-2365	Internal Retaining Ring	(1)
5	38-50-5600	Spindle	(1)
6	32-75-3200	Gear	(1)
7	02-50-2423	Roller Bearing	(1)
8	06-82-7395	8-16 x 1-3/4" Pan Hd. Plastite Screw	(4)
9	14-30-0481	Gear Case Assembly	(1)
10	34-40-4140	O-Ring	(1)

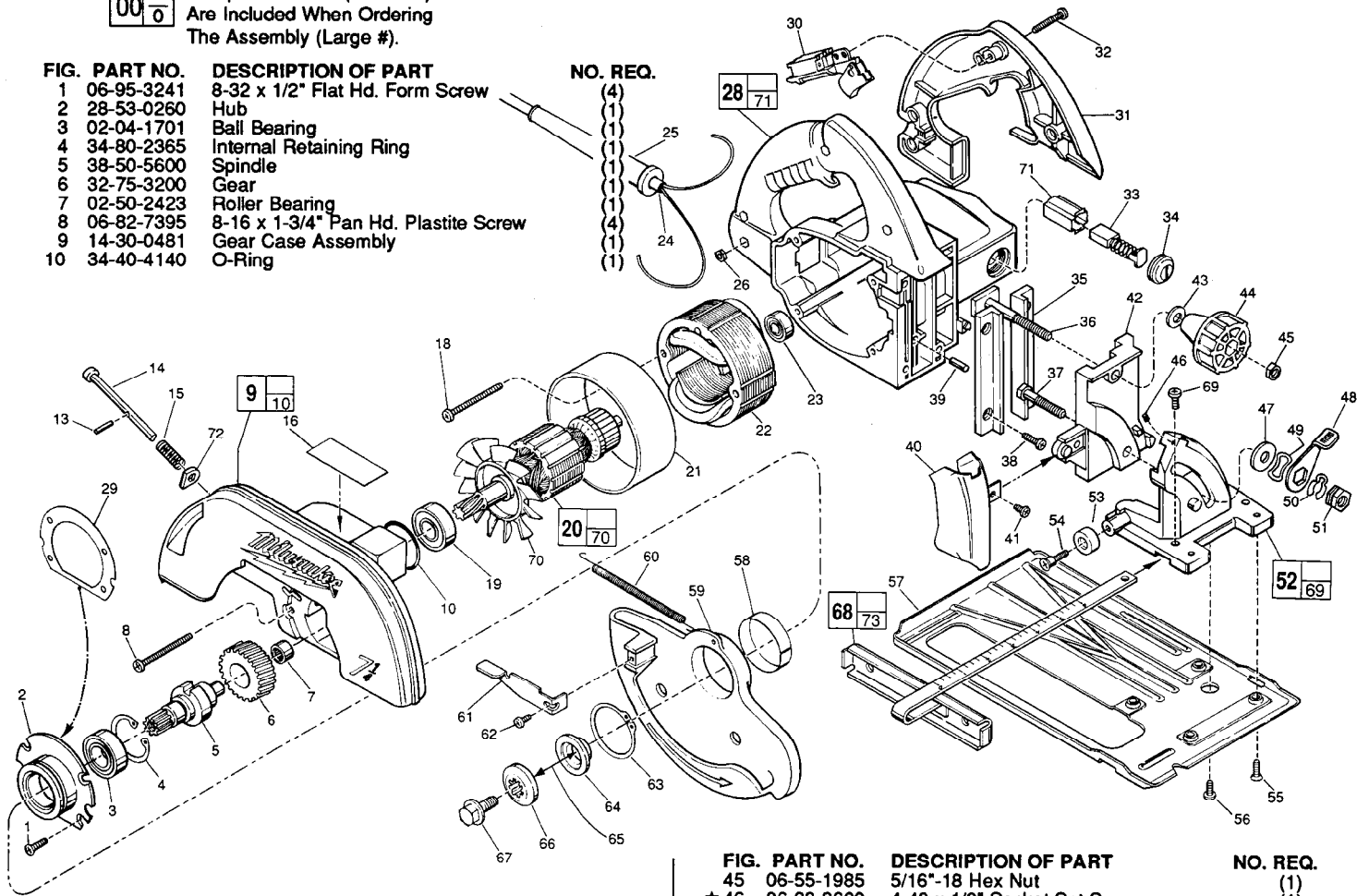

★ 13	06-65-1534	1/8" x 5/8 Roll Pin	(1)
14	45-08-0200	Spindle Lock Shaft	(1)
15	40-50-8040	Spindle Lock Spring	(1)
16	12-99-0358	Nameplate Blank	(1)
★ 18	06-95-7395	8-16 x 1-3/4" Pan Hd. Swage Form Screw	(2)
19	02-04-1700	Ball Bearing	(1)
★ 20	16-70-0285	120 V Armature	(1)
21	42-14-0310	Baffle	(1)
★ 22	18-70-0032	120 V Field	(1)
23	02-04-0850	Ball Bearing	(1)
24	22-64-0785	Cord Set	(1)
25	44-76-0050	Cord Protector	(1)
26	06-55-0835	8-32 Hex Nut	(4)
★ 28	31-50-0521	Motor Housing Assembly	(1)
29	43-44-0800	Gasket	(1)
30	23-66-0167	Switch	(1)
★ 31	31-44-1421	Handle Half-Left	(1)
32	06-82-2362	8-32 x 1" Pan Hd. Slot T-20	(4)
33	22-18-0550	Carbon Brush Assembly	(2)
34	23-44-0160	Brush Retaining Screw	(2)
35	28-72-0049	Vertical Adjusting Plate	(2)
36	45-58-0310	Vertical Adjusting Stud	(2)
37	45-58-0270	Angular Adjusting Stud	(1)
38	06-82-7270	8-16 x 5/8" Slot. Plastite T-20	(4)
39	06-65-1580	3/16" x 1/2" Roll Pin	(1)
★ 40	43-54-0547	Front Blade Guard	(1)
41	06-82-7252	8-32 x 3/8" Pan Hd. Taptite T-20	(1)
★ 42	25-10-0799	Vertical Adjusting Bracket	(1)
43	45-88-0660	Adjusting Washer	(1)
44	43-98-0190	Vertical Adjusting Knob	(1)

FIG.	PART NO.	DESCRIPTION OF PART	NO. REQ.
45	06-55-1985	5/16"-18 Hex Nut	(1)
★ 46	06-83-3620	4-40 x 1/2" Socket Set Screw	(1)
47	45-88-0650	Angle Adjusting Washer	(1)
48	44-10-0200	Lever	(1)
49	45-88-0577	Wave Washer	(1)
50	34-60-2330	Klipring	(1)
51	44-40-0460	Adjustment Nut	(1)
52	28-10-0791	Angular Adjustment Bracket Assembly	(1)
53	42-38-0221	Rubber Bumper	(1)
54	45-04-0485	10-32 x 13/16" Bumper Screw	(1)
55	06-95-3250	8-32 x 5/8" Flat Hd. Thread Form Screw	(4)
56	06-82-7252	8-32 x 3/8" Pan Hd. Taptite T-20	(1)
57	45-16-0541	Shoe	(1)
58	45-14-0230	Lower Guard Shim	(1)
59	28-41-0912	Lower Guard	(1)
60	40-50-4510	Lower Guard Spring	(1)
61	43-62-0910	Lower Guard Handle	(1)
62	06-82-7252	8-32 x 3/8" Pan Hd. Taptite T-20	(1)
63	34-60-2195	External Retaining Ring	(1)
64	43-34-0560	Inner Flange	(1)
65		7-1/4" Blade	(1)
66	45-88-0286	Spindle Washer	(1)
★ 67	06-75-0477	3/8"-24 x 11/16" Blade Screw	(1)
68	49-22-4150	Rip Fence (Optional)	(1)
69	06-95-0335	1/4"-20 x 1/2" Fil. Hd. Screw	(2)
70	22-84-0655	Fan Assembly	(1)
★ 71	22-20-0820	Brush Insert	(2)
49-96-6200		9/16" Utility Wrench	(1)
★ 72	45-88-8250	Felt Seal	(1)
★ 73	06-87-2450	1/4-20 x 1/2" Thumb Screw	(2)

FIG. LUBRICATION

9 3/4 Oz. Type "O" Grease, No. 49-08-4200.

MILWAUKEE ELECTRIC TOOL CORPORATION
13135 W. LISBON RD., BROOKFIELD, WI 53005