



# SERVICE PARTS LIST

**BULLETIN NO.**  
54-40-3200

SPECIFY CATALOG NO. AND SERIAL NO. WHEN ORDERING PARTS		REVISED BULLETIN	DATE
SINGLE SPEED JIG SAW			May '80
CATALOG NO.	6252	WIRING INSTRUCTION	
STARTING SERIAL NO.	553-1001	58-01-0091	

2.3 AMPS

FOR CAT. NO. 6252-2  
(240V) TOOL USE:  
22-64-4100 CORD SET  
22-18-0376 CARBON BRUSH  
18-26-1160 FIELD  
16-26-1160 ARMATURE

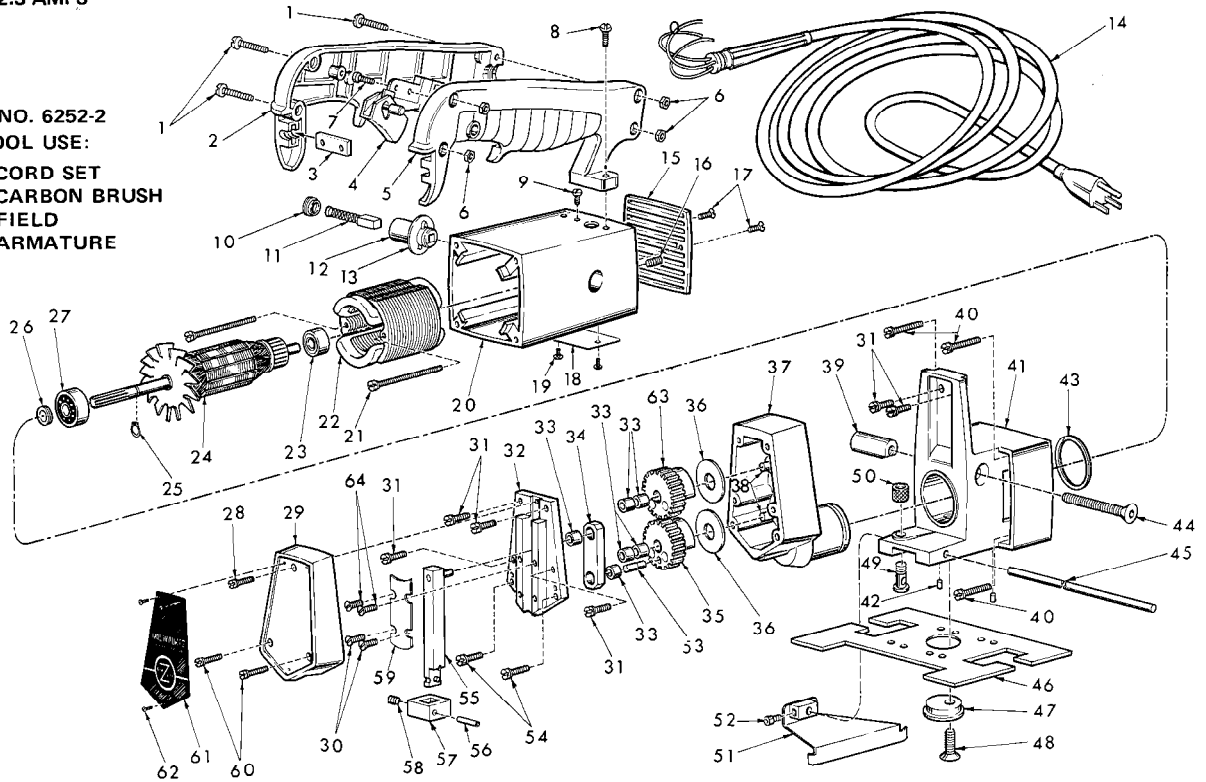

FIG.	PART NO.	DESCRIPTION OF PART	NO. REQ.	FIG.	PART NO.	DESCRIPTION OF PART	NO. REQ.
1	06-81-0425	8-32x7/8 Pan Hd. Screw	(4)	35	32-48-1001	Mechanism Gear -Lower	(1)
2	31-44-0520	Handle-Right Half	(1)	36	45-88-0380	Thrust Washer	(2)
3	44-66-0630	Nut Plate	(1)	37	14-30-0220	Gear Case Assy. (Includes Fig. 38)	(1)
4	23-66-0940	On-Off Switch	(1)	38	44-60-0260	Mechanism Pin	(2)
5	31-44-0530	Handle-Left Half	(1)	39	44-68-0100	Locking Plug	(1)
6	06-55-0825	8-32-Hex Nut	(4)	40	06-81-6300	8-32x7/8 Fil. Hd. Sem	(4)
7	06-95-0215	8-18x1/2 Pan Hd. Thread Forming Screw	(1)	41	14-13-0100	Diaphragm Assy. (Includes Fig. 42)	(1)
8	06-81-0047	8-32x1/2 Pan Hd. Screw	(2)	42	06-65-0630	3/16x1/2 Drivlok Pin	(2)
9	06-81-8625	6-32x1/4 Ground Screw	(1)	43	34-60-2125	Retaining Ring	(1)
10	23-44-0020	Brush Retaining Screw	(2)	44	06-81-3125	5/16-18x1-3/4 Skt. Flat Hd. Screw	(1)
11	22-18-0155	Carbon Brush	(2)	45	44-94-0080	Rip Guide Rod	(1)
12	22-22-1050	Brush Holder Assembly	(2)	46	45-16-0231	Saw Shoe	(1)
13	23-86-0105	Insulating Washer	(2)	47	45-88-0370	Shoe Adjusting Washer	(1)
14	22-64-0225	Cord Set	(1)	48	06-81-3075	5/16-18x3/4 Skt. Flat Hd. Screw	(1)
15	28-39-0221	Grill Casting	(1)	49	45-58-0120	Locking Stud	(1)
16	06-83-2430	10-32x1/4 Hdls. Skt Screw	(2)	50	44-40-0210	Locking Nut	(1)
17	06-81-3450	6-32x5/16 Oval Hd. Screw	(2)	51	44-66-0300	Plate Assembly	(1)
18	12-99-0100	Nameplate Blank	(1)	52	06-75-1985	8-32x5/16 Skt. Screw	(1)
19	06-81-8200	4-36x3/16 Rd. Hd. Sem	(2)	53	44-60-0250	Connecting Rod Pin	(1)
20	28-50-4982	Motor Housing	(1)	54	06-81-6402	8-32x1-1/8 Fil. Hd. Sem	(2)
21	06-81-5950	6-32x1-7/8 Fil. Hd. Sem	(2)	55	38-50-4963	Spindle Assy. (Incl. Figs. 56 thru 58)	(1)
22	18-22-1121	115 Volt Reversing Field	(1)	56	06-65-0900	5/32x9/16 Roll Pin	(1)
23	02-04-0740	Ball Bearing	(1)	57	42-68-0195	Blade Clamp	(1)
24	16-22-1190	115 Volt Armature (Includes Fig. 25)	(1)	58	06-83-2430	10-32x1/4 Hdls. Skt. Screw	(1)
25	34-60-0550	Retaining Ring	(1)	59	42-92-0152	Bearing Plate Cover	(1)
26	45-28-0090	Grease Slinger	(1)	60	06-81-5850	6-32x5/8 Fil. Hd. Sem	(2)
27	02-04-0940	Ball Bearing	(1)	61	12-75-1900	Identification Plate	(1)
28	06-81-5825	6-32x1/2 Fil. Hd. Sem	(1)	62	06-81-8200	4-36x3/16 Rd. Hd. Sem	(3)
29	28-20-1061	Gear Case Cover	(1)	63	32-48-1002	Mechanism Gear-Upper	(1)
30	06-81-5502	8-32x3/8 Comb. Hd. Sems	(2)	64	06-81-0452	8-32x3/8" Pan Hd. Screw	(2)
31	06-81-6102	8-32x7/16 Comb. Hd. Sems	(6)		48-66-4080	Key Holder (Not Shown)	
32	42-24-0181	Spindle Bearing Plate	(1)		49-96-0050	3/32 Socket Wrench (Not Shown)	
33	02-50-1200	Needle Bearing	(6)		49-96-0080	3/16 Socket Wrench (Not Shown)	
34	44-94-0131	Connecting Rod	(1)		49-96-0065	9/64 Socket Wrench (Not Shown)	
					12-98-7082	Caution Plate (Not Shown)	