

9.6V 3/8" KEYLESS DRILL

Model 6221DWE

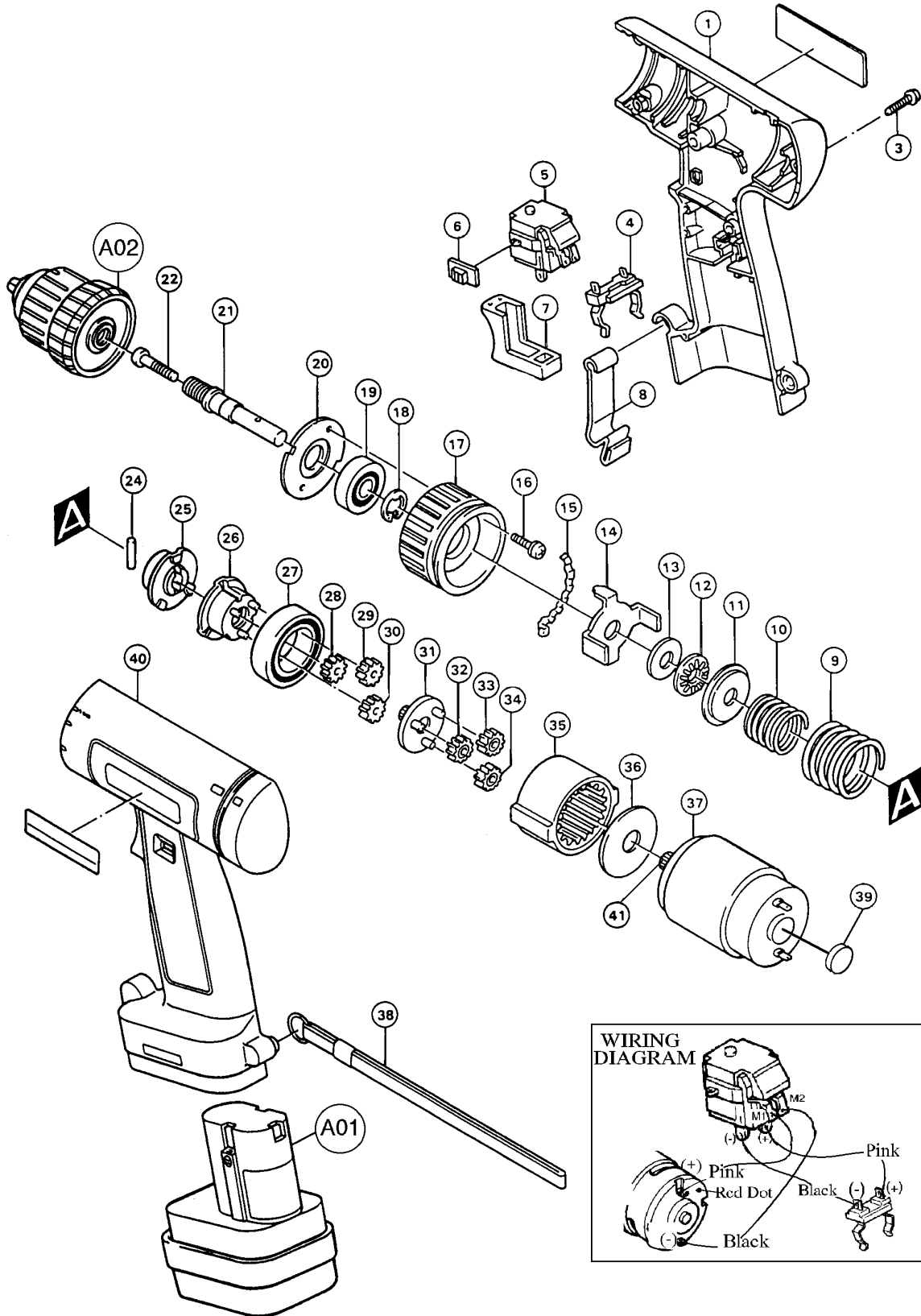

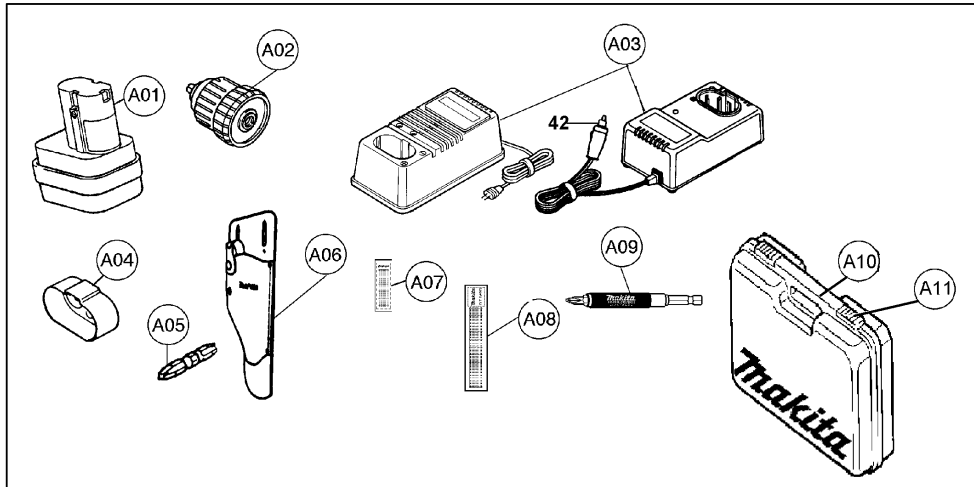

Item No.	Part No.	No. Used	Description	Item No.	Part No.	No. Used	Description
1	*	1	Housing (R)	41	226281-0	1	Spur Gear 9
3	265995-6	7	Tapping Screw BT4x18	42	655000-B	1	Plug for Cigarette Lighter
4	643909-9	1	Battery Holder	Accessories			
5	651909-5	1	Switch	A01	192019-4	1	Battery 9100
6	414740-8	1	Lever	A02	192016-0	1	3/8" Keyless Drill Chuck 10
7	415671-4	1	Switch Lever		763102-0	1	3/8" Locking Keyless Chuck (Old 192282-9)
8	344121-1	1	Set Plate	A03	CACDC9700	1	1 Hour Dual Voltage Fast Charger (AC Only) (DC9700)(7.2V & 9.6V)
9	233044-7	1	Compression Spring 27		DC1422	1	Automotive Quad Voltage Charger F/1.3, 1.7, 2.0 & 2.2Ah & F/7.2V, 9.6V, 12V & 14.4V Ni-Cad. & Ni-MH Batteries) (Includes Item 42) (Old CAADC1412)
10	*	1	Compression Spring 22	A04	414938-7	1	Battery Cover
11	267705-7	1	Washer 10	A05	-----	1	Bit (See Catalogue for Details)
12	216401-4	1	Thrust Needle Gauge 1023	A06	-----	1	Tool Holster (See Catalogue for Details)
13	253180-3	1	Flat Washer 10	A07	122237-A	1	Bit Patch Holder
14	165087-0	1	Slider	A08	122238-A	1	Bit Band Holder
15	344131-8	2	Cam Plate	A09	784810-A	1	Finder/Driver
16	911023-2	2	P.H. Screw M3x14 (With Washer)		784811-A	1	Stubby Finder/Driver
17	415515-8	1	Change Ring		784812-A	1	Finder/Driver II
18	961015-1	1	Stop Ring E-9		784814-A	1	Vision Finder/Driver
19	211061-7	1	Ball Bearing 6000LLB		784815-A	1	Quick Driver 6
20	285678-2	1	Bearing Retainer 14		784816-A	1	Quick Driver 8
21	*	1	Spindle		784817-A	1	Quick Driver 10
22	251451-2	1	P.H. Screw M5x22		784818-A	1	Quick Flip Driver
24	*	1	Pin 4/Steel Ball 5.6		784822-A	1	4 pc Quick Driver
25	*	1	Clutch Cam	A10	824447-2	1	Plastic Carrying Case (Includes Item A11)
26	153229-8	1	Clutch Cam Com.	A11	186347-7	2	Slide Lock
27	211375-4	1	Ball Bearing 6805LLB				
28	226284-4	1	Spur Gear 15				
29	226284-4	1	Spur Gear 15				
30	226284-4	1	Spur Gear 15				
31	153228-0	1	Spur Gear 9 Com.				
32	226283-6	1	Spur Gear 15				
33	226283-6	1	Spur Gear 15				
34	226283-6	1	Spur Gear 15				
35	226285-2	1	Internal Gear 42				
36	267067-3	1	Flat Washer 12				
37	*	1	DC Motor 9.6V (With Item 41)				
38	163319-9	1	Hand Strap				
39	689056-2	1	Sleeve 10 (Added)				
40	*	1	Housing (L)				

* SEE SERVICE CHANGES

SERVICE CHANGES

1. Change on Motor and Housing.

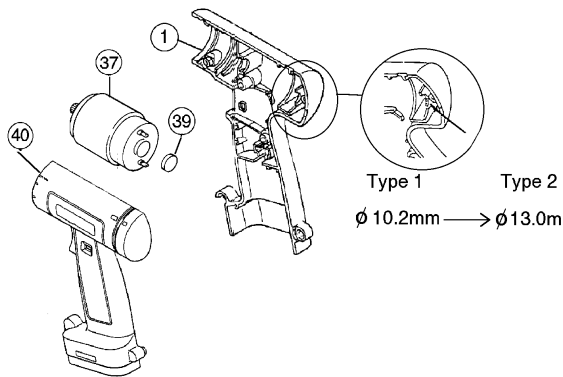

Item No.	Description	Type 1	Type 2
1	Housing (R)	415513-2 (Discontinued)	182819-0 (Set) (Old 415956-8)
37	DC Motor 9.6V	629671-0 (Discontinued) (With Item 41)	629694-8 (With Items 39 & 41)
39	Sleeve 10	-----	689056-2 (Added)
40	Housing (L)	415514-0 (Discontinued)	182819-0 (Set) (Old 415957-6)

Above parts are completely interchangeable as a set.

When replacing Motor (Type 2) into Type 1 Housing, please take out sleeve from Type 2 Motor.

2. Change on Clutch, Spindle etc.,

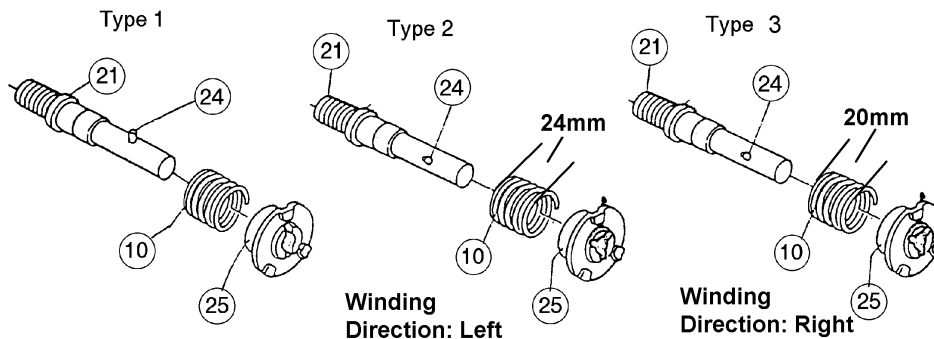

Item No.	Description	Type 1	Type 2	Type 2
10	Compression Spring 22	233043-9	233061-7	233196-4
21	Spindle	322690-2 (Discontinued)	322880-7	
24	Pin4/Steel Ball 5.6	256054-7 Pin 4	216011-7 Steel Ball 5.6	
25	Clutch Cam	223101-9 (Discontinued)	223115-8	

Above parts are completely interchangeable as a set.