



SERVICE PARTS LIST

BULLETIN NO.

54-40-0900

SPECIFY CATALOG NO. AND SERIAL NO. WHEN ORDERING PARTS		REVISED BULLETIN	DATE
14" PREMIUM CUT-OFF MACHINE			May 2011
CATALOG NO. 6180-20	STARTING SERIAL NO. 896A	WIRING INSTRUCTION 58-01-0575	

00 0

EXAMPLE:

Component Parts (Small #) Are Included When Ordering The Assembly (Large #).

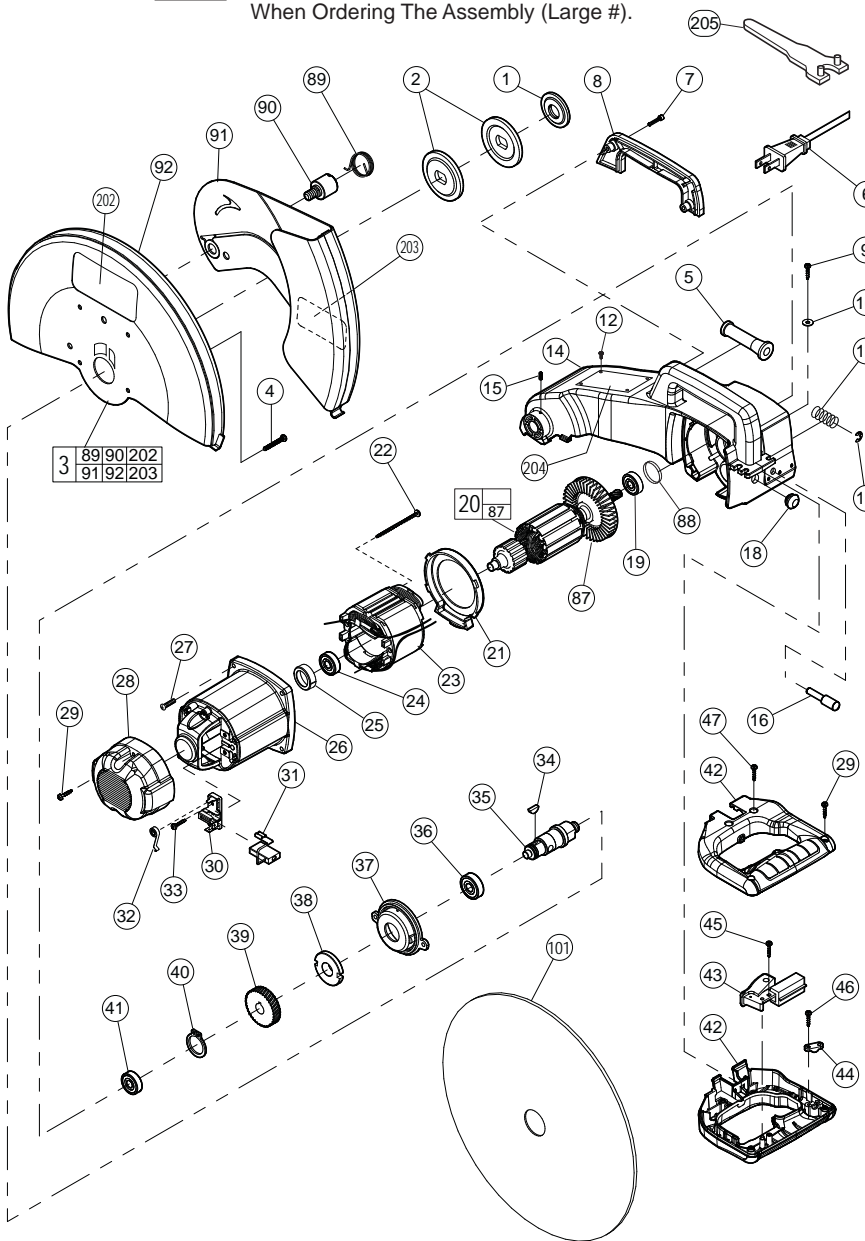

FIG.	PART NO.	DESCRIPTION OF PART	NO REQ.
1	05-59-0120	M14 Fixtec Nut	(1)
1a	49-05-0130	Flange Nut	(1)
2	43-34-0420	Flange	(2)
3	43-54-1030	Safety Cover Assembly	(1)
4	05-81-0735	M5 x 20 Pan Hd. Screw	(4)
5	44-76-0040	Cord Protector	(1)
6	22-64-0800	Cord	(1)
7	05-74-0030	M4 x 16 Socket Hd. Hex Screw	(2)
8	31-44-0170	Handle Cover	(1)
9	05-78-0030	TS5 x 20 Tapping Screw	(2)
10	45-88-1025	Flat Washer	(2)
11	40-50-0275	Spindle Lock Spring	(1)
12	06-72-1720	Service Rivet	(4)
13	05-92-0065	Retaining Ring	(1)
14	31-40-0085	Gear Housing	(1)
15	05-86-0100	M4 x 10 Hex Socket Set Screw	(1)
16	44-60-0995	Spindle Lock Pin	(1)
18	22-90-0010	Rubber Grommet	(1)
19	02-04-0060	Ball Bearing	(1)
20	16-70-0540	Armature	(1)
21	42-14-0420	Fan Guide	(1)
22	05-78-0035	TS5 x 75 Tapping Screw	(2)
23	18-70-0540	Field	(1)
24	02-04-0065	Ball Bearing	(1)
25	42-96-0020	Rubber Cup	(1)
26	28-50-0040	Motor Housing	(1)
27	05-81-0775	M5 x 30 Pan Hd. Screw	(4)
28	42-92-0090	Motor Cover	(1)
29	05-78-0040	TS4 x 18 Tapping Screw	(4)
30	22-20-0025	Carbon Brush Holder	(2)
31	22-16-0045	Carbon Brush	(2)
32	40-50-0280	Brush Spring	(2)
33	05-78-0045	TS4 x 12 Tapping Screw	(4)
34	05-42-0020	Woodruff Key	(1)
35	38-50-0090	Spindle Shaft	(1)
36	02-04-0070	Ball Bearing	(1)
37	42-92-0095	Front Brg. Cover (Incl. Rubber Retainer)	(1)
38	42-76-0705	Spindle Stop Collar	(1)
39	32-75-0025	Gear	(1)
40	05-92-0075	Retaining Ring	(1)
41	02-04-1090	Ball Bearing	(1)
42	31-44-0175	D-Handle Halves	(1)
43	23-66-1035	Switch (Incl. 4 Screws & Star Washers)	(1)
44	44-76-0045	Strain Relief	(1)
45	05-78-0050	TS4 x 10 Tapping Screw	(1)
46	05-78-0020	TS4 x 14 Tapping Screw	(2)
47	05-78-0055	TS4 x 28 Tapping Screw	(2)
87	22-84-0090	Fan with Bushing	(1)
88	34-40-6180	O-Ring	(1)
89	-----	Safety Cover Spring	(1)
90	-----	Spring Retainer Pivot Bolt	(1)
91	-----	Outer Safety Cover	(1)
92	-----	Safety Cover	(1)
101	-----	14" Abrasive Wheel	(1)
202	10-15-2560	Logo Label	(2)
203	10-20-3055	'No Toothed Blade' Label	(1)
204	12-99-6180	Service Nameplate	(1)
205	49-96-0390	Spanner Wrench	(1)

FIG. LUBRICATION:

14 Place 1 to 1.25 ounces (28 - 35 grams) of Type 'Y' Grease, No. 49-08-5270, in the gear cavity of the gear housing.

FIG. NOTES:

1, 1a, Fixtec nut (05-59-0120) has a built in hinged lever for hand tightening or removal.

Flange nut (49-05-0130) must be tightened or removed with spanner wrench (49-96-0390).

19 Seal to face spindle gear.

24 Seal to face armature.

25 Place in motor housing prior to inserting armature.

SERVICE TOOLS:

61-10-1025	3/8" Slide Hammer Attachment	(1)
61-10-1050	1/2" Slide Hammer Attachment	(1)
61-10-1075	1/4" Slide Hammer Attachment	(1)

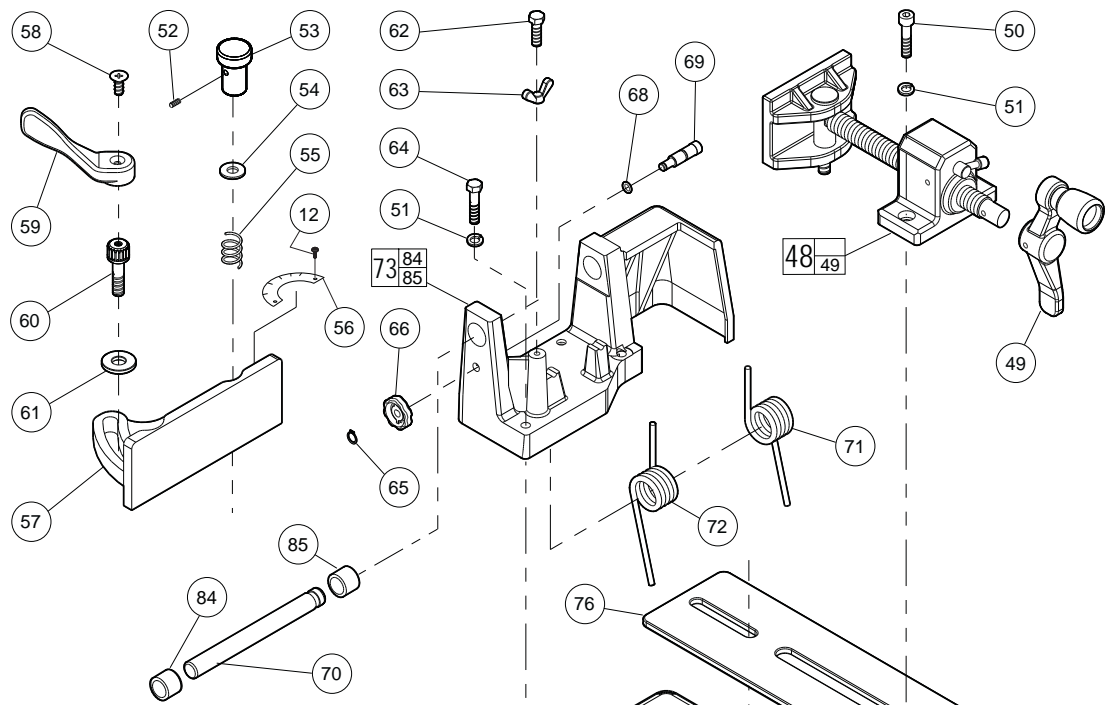
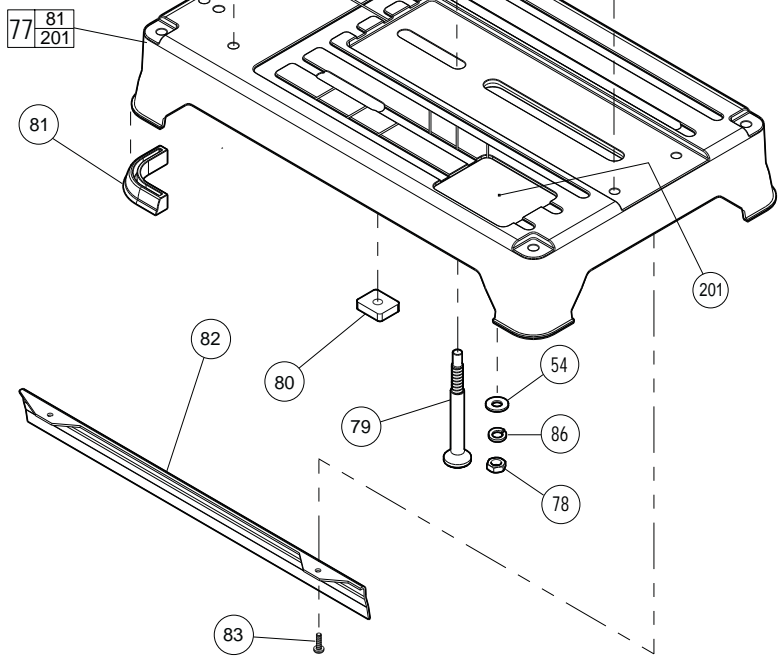

FIG.	PART NO.	DESCRIPTION OF PART	NO REQ.
	12	06-72-1720 Service Rivet	(2)
	48	45-84-0120 Service Vise Assembly	(1)
	49	45-84-0125 Vise Handle Set (Includes two 1/4-20 Cup Point Set Screws, No. 06-83-6035, threaded into handle collar)	(1)
	50	05-74-0035 M8 x 35 Socket Hd. Hex Screw	(2)
	51	05-90-0030 Split Washer	(6)
	52	05-86-0105 M5 x 6 Hex Socket Set Screw	(1)
	53	43-98-0020 Fence Guide Knob	(1)
	54	45-88-1355 Flat Washer	(2)
	55	40-50-0285 Spring	(1)
	56	43-82-0140 Scale Indicator	(1)
	57	42-68-0715 Fence Guide	(1)
	58	05-80-0440 M6 x 12 Counter Sunk Hd. Screw	(1)
	59	44-10-0325 Fence Guide Lever	(1)
	60	42-32-0310 Fence Bolt	(1)
	61	45-88-1360 Flat Washer	(1)
	62	05-75-0010 M8 x 45 Hex Hd. Screw	(1)
	63	06-59-0110 M8 Thumb Screw	(1)
	64	05-75-0020 M8 x 50 Hex Hd. Screw	(4)
	65	05-92-0080 Retaining Ring	(1)
	66	31-01-0055 Transportation Lock Handle	(1)
	68	34-40-0030 O-Ring	(1)
	69	44-50-0100 Transportation Lock Pin	(1)
	70	06-65-3745 Pivot Shaft	(1)
	71	40-50-0320 Torsion Spring (Right)	(1)
	72	40-50-0325 Torsion Spring (Left)	(1)
	73	42-36-1745 Pivot Block with Bushings	(1)
	74	42-92-0135 Cover Plate	(1)
	76	44-66-0210 Vise Guide Plate	(1)
	77	28-06-1120 Base	(1)
	78	05-55-0120 M10 Hex Nut	(1)
	79	42-32-0315 Fence Guide Bolt	(1)
	80	05-59-0110 Fence Guide Nut	(1)
	81	44-34-0210 Rubber Foot	(4)
	82	43-54-0350 Base Side Shield	(1)
	83	05-81-0745 M4 x 10 Pan Hd. Screw	(4)
	84	----- Bushing (20mm) Incl. with Pivot Block	(1)
	85	----- Bushing (22mm) Incl. with Pivot Block	(1)
	86	45-88-1370 Split Washer	(1)
	93	42-92-0135 Cover Plate	(1)
	94	05-78-0410 M4 x 12 Pan Hd. Screw	(2)
	201	10-15-0425 Warning Label	(1)



NOTE:
 #93 Cover Plate (42-92-0135) and #94 Screws (05-78-0410) were utilized on early version Base Assemblies to close off an opening in the back of the Base. This is on tools with serial number breaks 896A and 896B.
 Later versions of that Base Assembly have that opening closed off in the casting.

FIG. NOTES:
 48,49 Vise handle set includes two (2) 1/4-20 cup point set screws threaded into handle collar.
 77,81 If replacing the rubber feet, 3M Scotch-Grip® Rubber Cement, No. 44-22-0060, must be used to hold onto the base.