

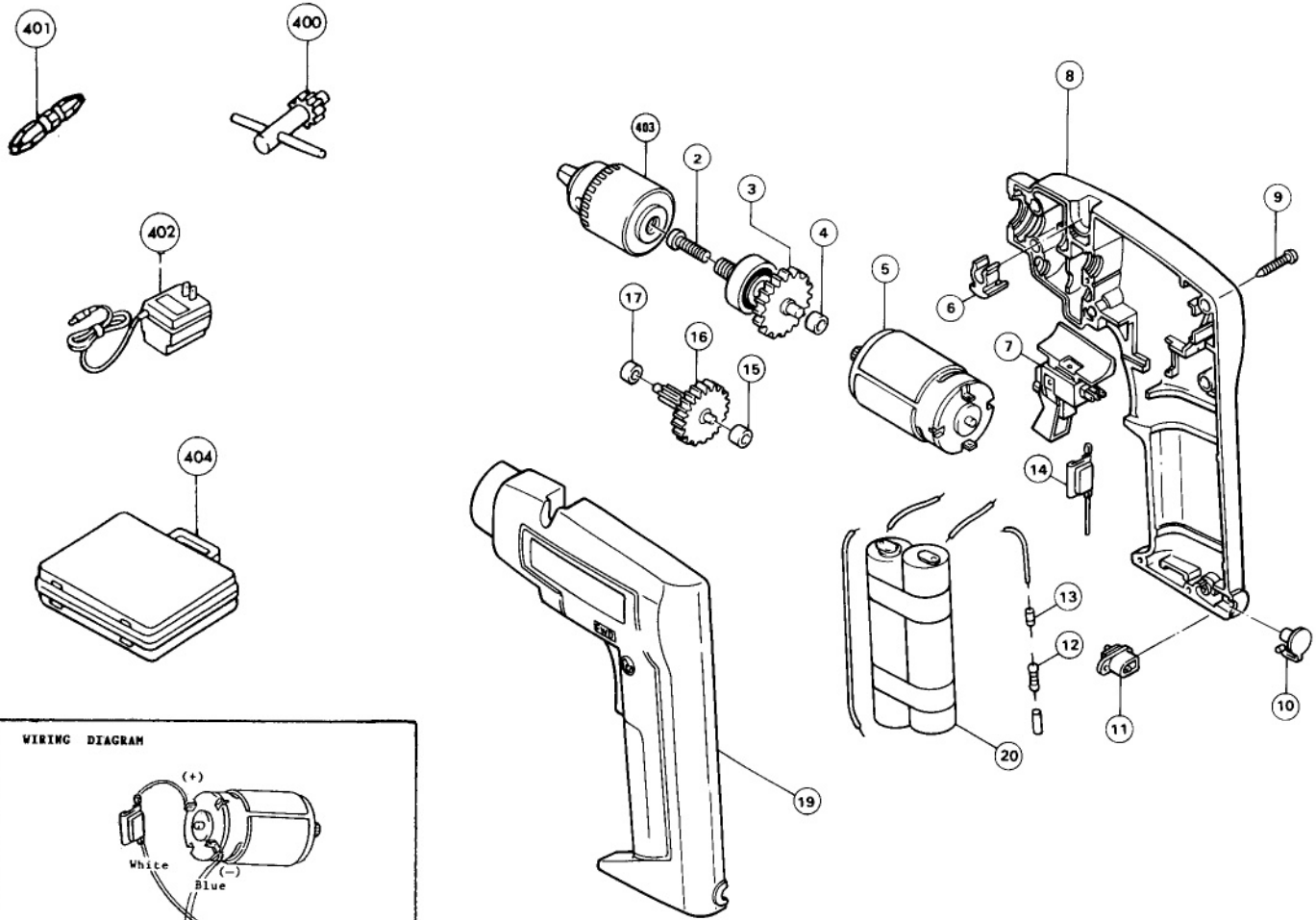

3/8" CORDLESS DRIVER-DRILL

Model 6170D Model 6170DW



IMPORTANT — To assure product **SAFETY** and **RELIABILITY**, repairs, maintenance or adjustments should be performed by **MAKITA** Service Centers or other qualified service organizations. Always use **MAKITA** replacement parts.

Fig.	Part No.	Qty. Used	Description	Fig.	Part No.	Qty. Used	Description
2	251448-1	1	Pan Head Screw M5x18	16	226048-6	1	Gear Complete 13-58
3	153155-1	1	Gear	17	214016-1	1	Plane bearing 3
4	214017-9	1	Plane Bearing 5	19	181866-8	1	Housing Set (Incl. Fig 8)
5	629514-6	1	Motor (Include Spur Gear 221851-0)	20	678037-1	1	Battery, 7.2VDC
6	411640-3	1	Holder 6	ACCESSORIES			
7	651908-7	1	Switch	400	763419-1		Chuck Key
8	181866-8	1	Housing Set (Incl. Fig 19)	401	{ 784202-3		#2 Phillips Bit (1-3/4" long)
9	265837-4	6	Tapping Screw 3x20		{ 784203-1		#2 Phillips Bit (2-5/8" long)
10	410472-5	1	Cap	402	155721-0		3 Hour Charger (Include Plug 655000-A)
11	655403-9	1	Inlet	403	763054-5-A		Chuck & Key Set (Include Fig. 400)
12	646627-8	1	Resistor	404	824379-3		Plastic Case
13	647037-2	1	Diode				
14	652685-4	1	Overload Protector				
15	214016-1	1	Plane Bearing 3				