

SPECIFY CATALOG NO. AND SERIAL NO. WHEN ORDERING PARTS		REVISED BULLETIN 54-38-1820	DATE Oct. 2012
6" ANGLE GRINDER with PADDLE SWITCH w/Lock-Off		WIRING INSTRUCTION See Page 3	
CATALOG NO. 6160-30	STARTING SERIAL NUMBER B74B		

FIG.	PART NO.	DESCRIPTION OF PART	NO. REQ.
2	05-88-1210	M4 x 14 Pan Hd. T-20 Screw	(4)
3	05-88-1250	M4 x 20 Pan Hd. T-20 Screw	(6)
5	05-88-1290	M4 x 76 Pan Hd. T-20 Screw	(2)
6	05-88-1300	M4 x 28 T-20 Screw	(2)
7	05-90-0225	M4 Lock Washer (See page 2)	(4 or 6)
9	10-15-1230	Warning Label	(1)
10	12-20-6116	Service Nameplate	(1)
11	40-50-1480	Torsion Spring	(1)
12	42-42-0620	Lock-Off Button	(1)
13	06-65-1280	Lock-Off Pin	(1)
17	14-34-0725	Rear Handle Assembly	(1)

Rubber Slug (30) is to be placed in a cavity by the bearing bore in the back of Motor Housing (29).

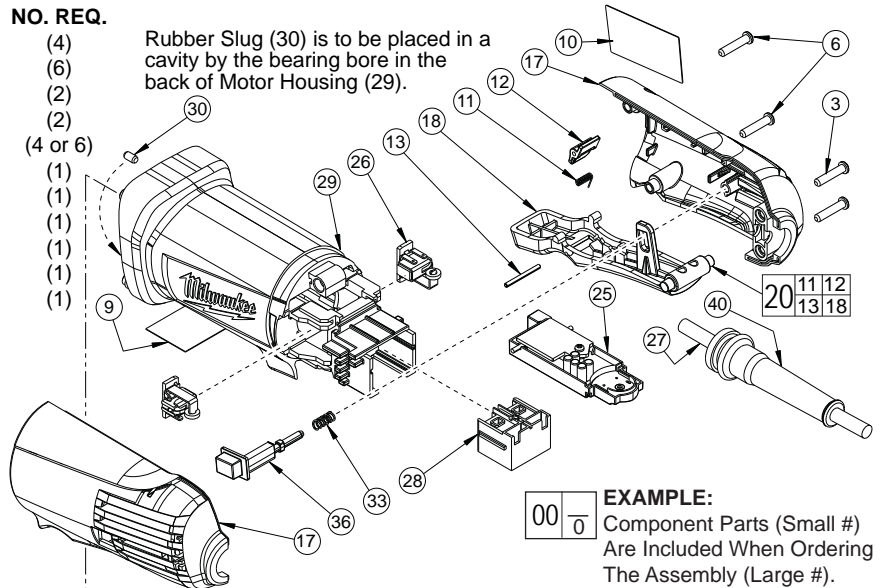
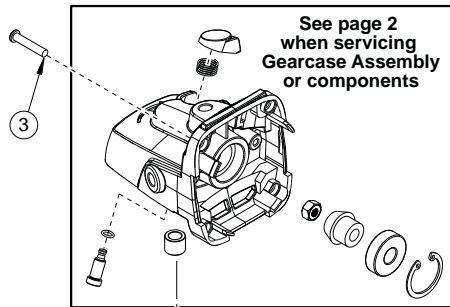

EXAMPLE:
00 0
Component Parts (Small #)
Are Included When Ordering
The Assembly (Large #).

*** LUBRICATION NOTE:** When servicing the Gears (31 & 50) or the Gearcase (42), 90-95% of the old grease must be removed prior to new grease being added.

Orient Magnetic Disc Assembly (56) with 'half moon' cut outs facing Ball Bearing (53) as shown. Exercise caution when installing. Make sure that the shoulder of Magnetic Disc Assembly rests against commutator bars with no visible gap.

Orient Fan Baffle (34) with small notch to the top and large notch to the bottom.

Orient Retaining Rings (39 & 51) so the bevel side faces away from Ball Bearings (48 & 55).

Orient the Needle Bearing (41) such that side with vendor I.D. is facing the Gear (50).

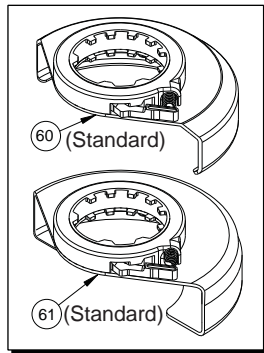
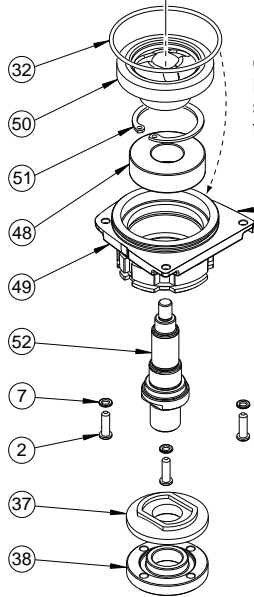
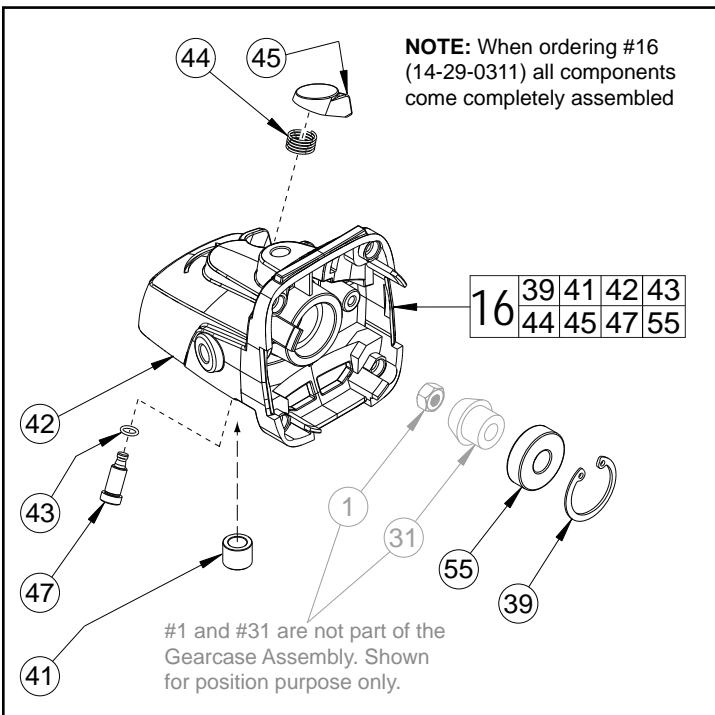

FIG.	PART NO.	DESCRIPTION OF PART	NO. REQ.
48	02-04-1150	Ball Bearing	(1)
49	28-53-0410	Lower Gearcase Hub	(1)
50	32-05-1310	Bevel Gear	(1)
51	34-80-2275	Retaining Ring	(1)
52	38-50-1280	Spindle	(1)
53	02-04-2110	Ball Bearing	(1)
54	45-88-0406	Washer	(1)
56	23-27-0110	Magnetic Disc Assembly	(1)
60	43-54-1080	6" T27 Guard Assembly (Standard)	(1)
61	43-54-1085	6" T1 Guard Assembly (Standard)	(1)
	42-62-0100	Side Handle (Not Shown)	(1)
	49-96-7215	Spanner Wrench (Not Shown)	(1)

FIG. LUBRICATION (*See lubrication note above):

- 31,50 Type "Y" Grease, No. 49-08-5270, Must Be Applied To All Gear Teeth.
- 32,42 Lightly coat with grease O-Ring and bearing bore in Gearcase.
- 42 .3 -.4 Ounces (9-12 Grams) Type "Y" Grease, No. 49-08-5270.

FIG.	PART NO.	DESCRIPTION OF PART	NO. REQ.
18	31-92-0420	Paddle	(1)
19	14-73-0410	Spindle/Hub Assembly	(1)
20	14-78-0500	Paddle Assembly	(1)
21	16-10-7010	Service Armature Assembly	(1)
23	18-07-2305	Service Field	(1)
25	22-09-1725	Module Assembly	(1)
26	22-22-1560	Carbon Brush Assembly	(2)
27	22-64-2020	Cord	(1)
28	23-66-2665	Switch	(1)
29	31-50-2420	Motor Housing	(1)
30	31-53-0240	Rubber Slug	(1)
32	34-40-0180	O-Ring	(1)
33	40-50-1625	Lock-On Spring	(1)
34	42-14-0490	Fan Baffle	(1)
36	42-42-0660	Lock-On Shaft	(1)
37	43-34-0036	Inner Disk Flange	(1)
38	44-40-0035	Outer Flange Nut	(1)
40	44-76-0210	Strain Relief	(1)



#16 14-29-0311 GEARCASE ASSEMBLY

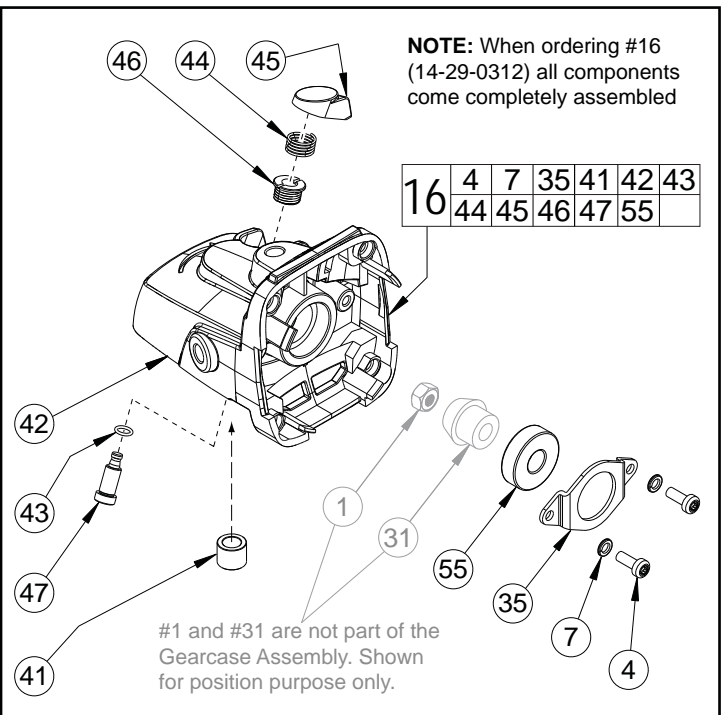

#16 14-29-0312 GEARCASE ASSEMBLY

FIG.	PART NO.	DESCRIPTION OF PART	NO. REQ.
1	05-55-0620	M5 Armature Hex Nut	(1)
16	14-29-0311	Gearcase Assembly	(1)
31	32-60-1310	Bevel Pinion	(1)
39	34-80-1001	Retaining Ring	(1)
41	02-50-0025	Needle Bearing	(1)
42	-----	Gearcase	(1)
43	34-40-0450	O-Ring	(1)
44	40-50-1330	Compression Spring	(1)
45	42-42-0590	Spindle Lock Button	(1)
47	42-60-1660	Spindle Lock Pin	(1)
55	02-04-0620	Ball Bearing	(1)

- FIG. NOTE:**
- 1 Torque Armature Nut (1) to 47 in/lbs, 55 kg/cm.
 - 41 Orient the Needle Bearing (41) such that the side with the vendor I.D. is facing the Gear (50).
 - 47,50 Functionally check Spindle Lock mechanism. Spindle Lock Pin (47) must return briskly when released from engagement in Gear (50), reference illustration on first page.

FIG.	PART NO.	DESCRIPTION OF PART	NO. REQ.
1	05-55-0620	M5 Armature Hex Nut	(1)
4	05-88-1280	M4 x 10 Pan Hd. T-20 Screw	(2)
7	05-90-0225	M4 Lock Washer (2 of 6)	(6)
16	14-29-0312	Gearcase Assembly	(1)
31	32-60-1310	Bevel Pinion	(1)
35	44-66-0450	Bearing Retainer	(1)
41	02-50-0025	Needle Bearing	(1)
42	-----	Gearcase	(1)
43	34-40-0450	O-Ring	(1)
44	40-50-1330	Compression Spring	(1)
45	42-42-0590	Spindle Lock Button	(1)
46	42-42-0580	Spindle Lock Tube	(1)
47	42-60-1660	Spindle Lock Pin	(1)
55	02-04-0620	Ball Bearing	(1)

- FIG. NOTE:**
- 1 Torque Armature Nut (1) to 47 in/lbs, 55 kg/cm.
 - 7 There are 2 Lock Washers (7) that are utilized in the 14-29-0312 Gearcase Assembly (13). There are 4 Lock Washers used to help secure the Lower Gearcase Hub (49). There is a total quantity of 6. Reference illustration above and on page 1.
 - 41 Orient the Needle Bearing (41) such that the side with the vendor I.D. is facing the Gear (50).
 - 46 When replacing Spindle Lock Tube (46), apply a few drops of thread locking sealant to outside threads prior to installation. Torque Spindle Lock Tube to 12 in/lbs, 14 kg/cm.
 - 47,50 Functionally check Spindle Lock mechanism. Spindle Lock Pin (47) must return briskly when released from engagement in Gear (50), reference illustration on first page.

AS AN AID TO REASSEMBLY, TAKE NOTICE OF WIRE ROUTING AND POSITION IN WIRE GUIDES AND TRAPS WHILE DISMANTLING TOOL. BE CAREFUL AND AVOID PINCHING WIRES BETWEEN HANDLE HALVES WHEN ASSEMBLING.

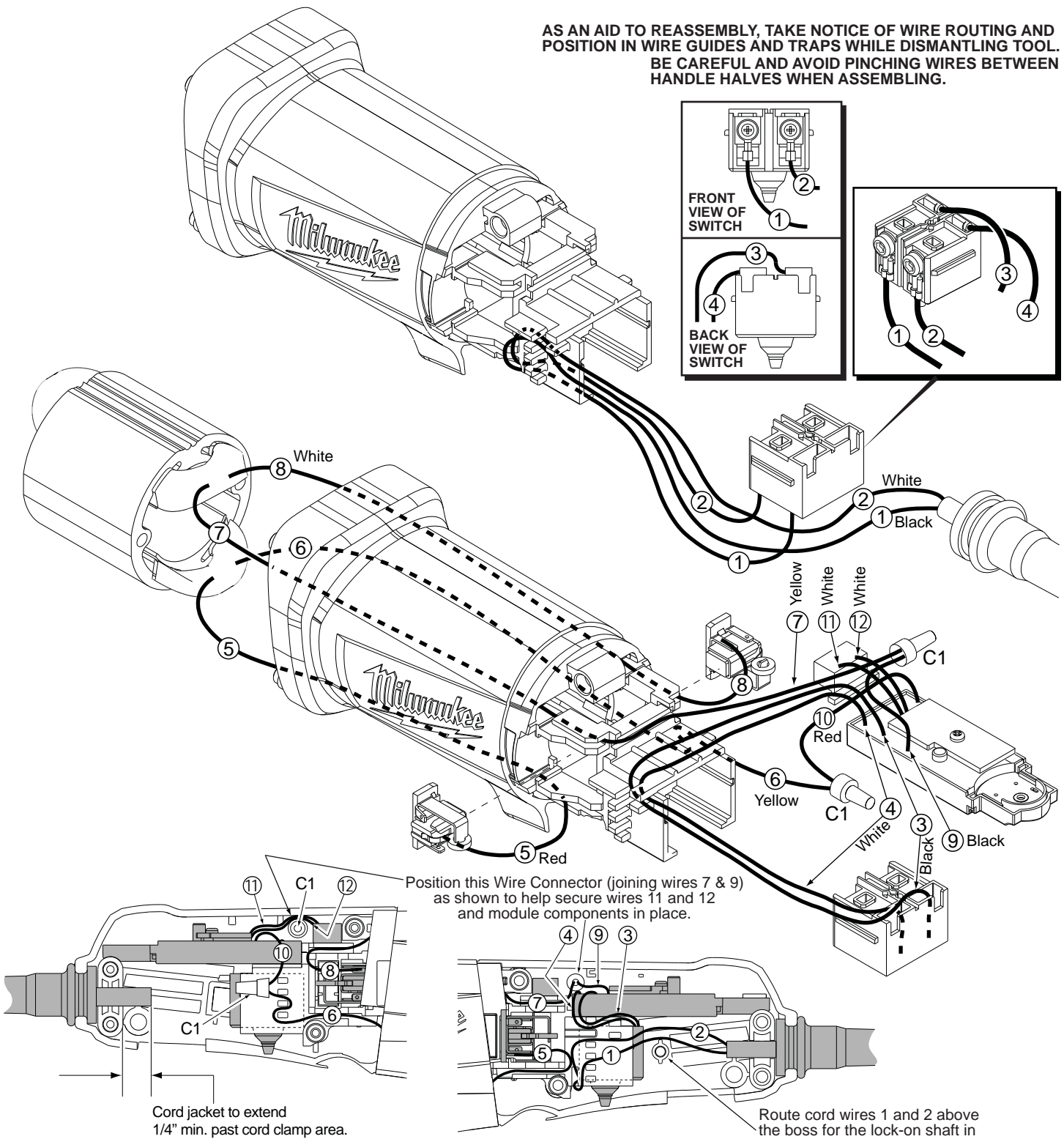

Position this Wire Connector (joining wires 7 & 9) as shown to help secure wires 11 and 12 and module components in place.

Cord jacket to extend 1/4" min. past cord clamp area.

Route cord wires 1 and 2 above the boss for the lock-on shaft in the right handle half.

WIRING SPECIFICATIONS

Wire No.	Wire Color	Origin or Part No.	Gauge	Length	Terminals, Connectors and End Wire Preparation
1	Black	22-64-2020	--	--	Component of cord set.
2	White	22-64-2020	--	--	Component of cord set.
3	Black	22-09-1725	--	--	Component of PC board.
4	White	22-09-1725	--	--	Component of PC board.
5	Red	18-07-2305	--	--	Component of field.
6	Yellow	18-07-2305	--	--	Component of field.
7	Yellow	18-07-2305	--	--	Component of field.
8	White	18-07-2305	--	--	Component of field.
9	Black	22-09-1725	--	--	Component of PC board.
10	Red	22-09-1725	--	--	Component of PC board.
11	White	22-09-1725	--	--	Component of PC board.
12	White	22-09-1725	--	--	Component of PC board.

BULK LEAD WIRE - BULLETIN 58-01-0003

NOTE:

All leads must be held to ± 1/16". All lead lengths are before stripping.

TERMINAL DESCRIPTION		
Code	Part No.	Qty.
CONNECTOR DESCRIPTION		
C1	22-56-0150	2