



# SERVICE PARTS LIST

**BULLETIN NO.**  
**54-38-6132**

SPECIFY CATALOG NO. AND SERIAL NO. WHEN ORDERING PARTS		REVISED BULLETIN 54-38-6131	DATE May 2014
<b>4.5" (115mm) ANGLE GRINDER</b>			
CATALOG NO.	<b>6130-33</b>	STARTING SERIAL NO.	<b>C27C</b>
		WIRING INSTRUCTION <b>SEE PAGE 3</b>	

★ = Part number change from previous service parts list.

**EXAMPLE:**  
Component Parts (Small #)  
Are Included When Ordering  
The Assembly (Large #).

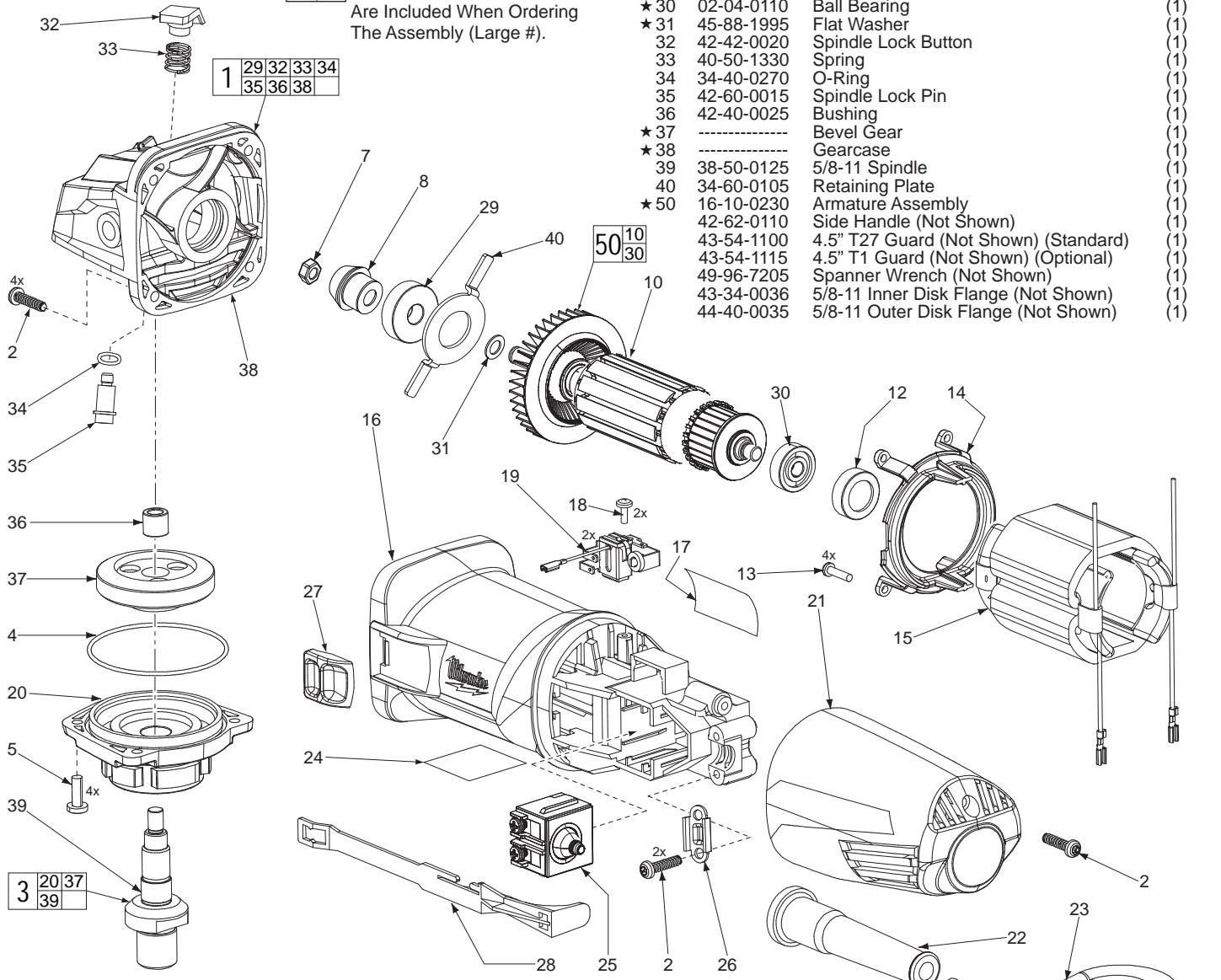

FIG.	PART NO.	DESCRIPTION OF PART	NO. REQ.
29	-----	Ball Bearing	(1)
★ 30	02-04-0110	Ball Bearing	(1)
★ 31	45-88-1995	Flat Washer	(1)
32	42-42-0020	Spindle Lock Button	(1)
33	40-50-1330	Spring	(1)
34	34-40-0270	O-Ring	(1)
35	42-60-0015	Spindle Lock Pin	(1)
36	42-40-0025	Bushing	(1)
★ 37	-----	Bevel Gear	(1)
★ 38	-----	Gearcase	(1)
39	38-50-0125	5/8-11 Spindle	(1)
40	34-60-0105	Retaining Plate	(1)
★ 50	16-10-0230	Armature Assembly	(1)
	42-62-0110	Side Handle (Not Shown)	(1)
	43-54-1100	4.5" T27 Guard (Not Shown) (Standard)	(1)
	43-54-1115	4.5" T1 Guard (Not Shown) (Optional)	(1)
	49-96-7205	Spanner Wrench (Not Shown)	(1)
	43-34-0036	5/8-11 Inner Disk Flange (Not Shown)	(1)
	44-40-0035	5/8-11 Outer Disk Flange (Not Shown)	(1)

FIG.	PART NO.	DESCRIPTION OF PART	NO. REQ.
★ 1	14-30-0170	Gearcase Assembly	(1)
2	05-88-1200	M4 x 16 Pan Hd. Plastite T-20 Screw	(7)
★ 3	14-73-0060	5/8-11 Spindle/Hub Assembly	(1)
4	34-40-0095	O-Ring	(1)
5	06-82-2380	#8-32 x 1/2" Pan Hd. Slit. Tapt. T-20 Screw	(4)
★ 7	05-55-0620	Nut	(1)
★ 8	32-60-0275	Bevel Pinion	(1)
★ 10	-----	Armature	(1)
★ 12	42-96-0177	Rubber Bearing Cup	(1)
★ 13	06-82-3002	Pan Hd. Taptite T-10 ST Screw	(4)
14	42-14-0020	Baffle	(1)
★ 15	18-07-0175	Service Field Assembly	(1)
16	31-50-0915	Motor Housing	(1)
17	12-20-0115	Service Nameplate Kit	(1)
18	05-88-1100	M3 x 10 Pan Hd. T-10 Screw	(2)
19	22-22-0085	Carbon Brush Assembly	(2)
20	14-73-0025	Lower Gearcase Hub	(1)
21	31-50-0935	Rear Handle	(1)
22	44-76-0210	Cord Protector	(1)
23	22-64-0565	Cordset	(1)
24	10-15-0155	Warning Label	(1)
25	23-66-0385	Switch	(1)
26	31-17-0040	Cord Clamp	(1)
27	31-92-0015	Slide Switch Button	(1)
28	31-92-0020	Slide Pole	(1)

**\* LUBRICATION NOTE:** When servicing the Gears (8 & 37) or the Gearcase (38), 90-95% of the old grease must be removed prior to new grease being added.

**FIG. LUBRICATION** (\*See lubrication note above):

- 8,37 Type "Y" Grease, No. 49-08-5270, Must Be Applied To All Gear Teeth.
- 4,38 Lightly coat with grease O-Ring and bearing bore in Gearcase.
- 38 .4 Ounces (13 Grams) Type "Y" Grease, No. 49-08-5270.

**MILWAUKEE ELECTRIC TOOL CORPORATION**  
13135 W. Lisbon Road, Brookfield, WI 53005  
Drwg. 1

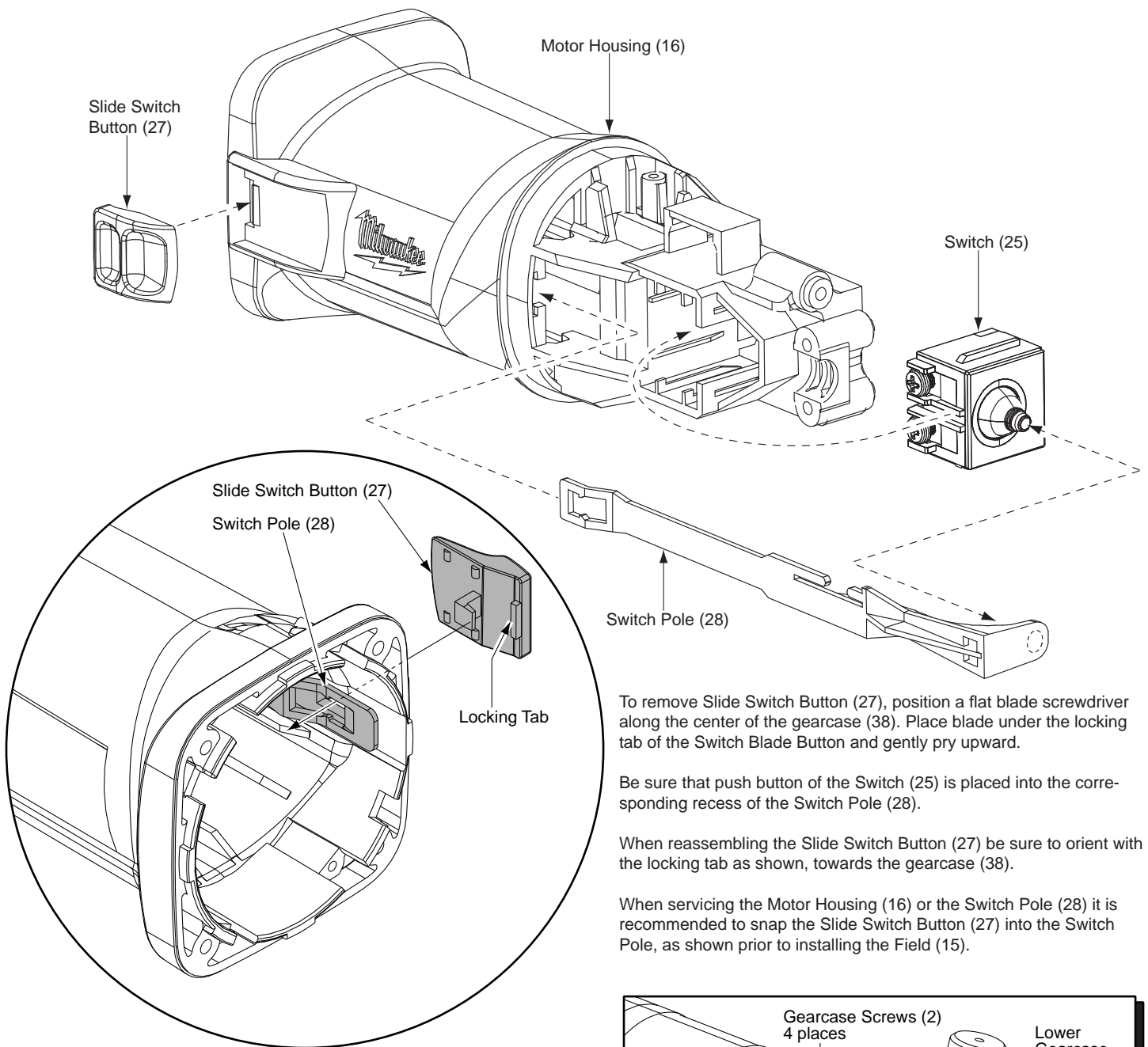

To remove Slide Switch Button (27), position a flat blade screwdriver along the center of the gearcase (38). Place blade under the locking tab of the Switch Blade Button and gently pry upward.

Be sure that push button of the Switch (25) is placed into the corresponding recess of the Switch Pole (28).

When reassembling the Slide Switch Button (27) be sure to orient with the locking tab as shown, towards the gearcase (38).

When servicing the Motor Housing (16) or the Switch Pole (28) it is recommended to snap the Slide Switch Button (27) into the Switch Pole, as shown prior to installing the Field (15).

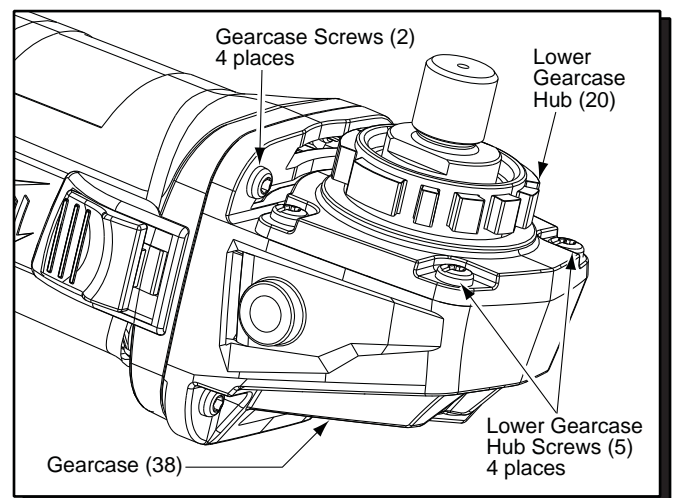

When servicing the Gearcase (38), first remove the four Screws (5) and Lower Gearcase Hub (20) to prevent damage to the bottom two Screws (2) that secure the Gearcase.

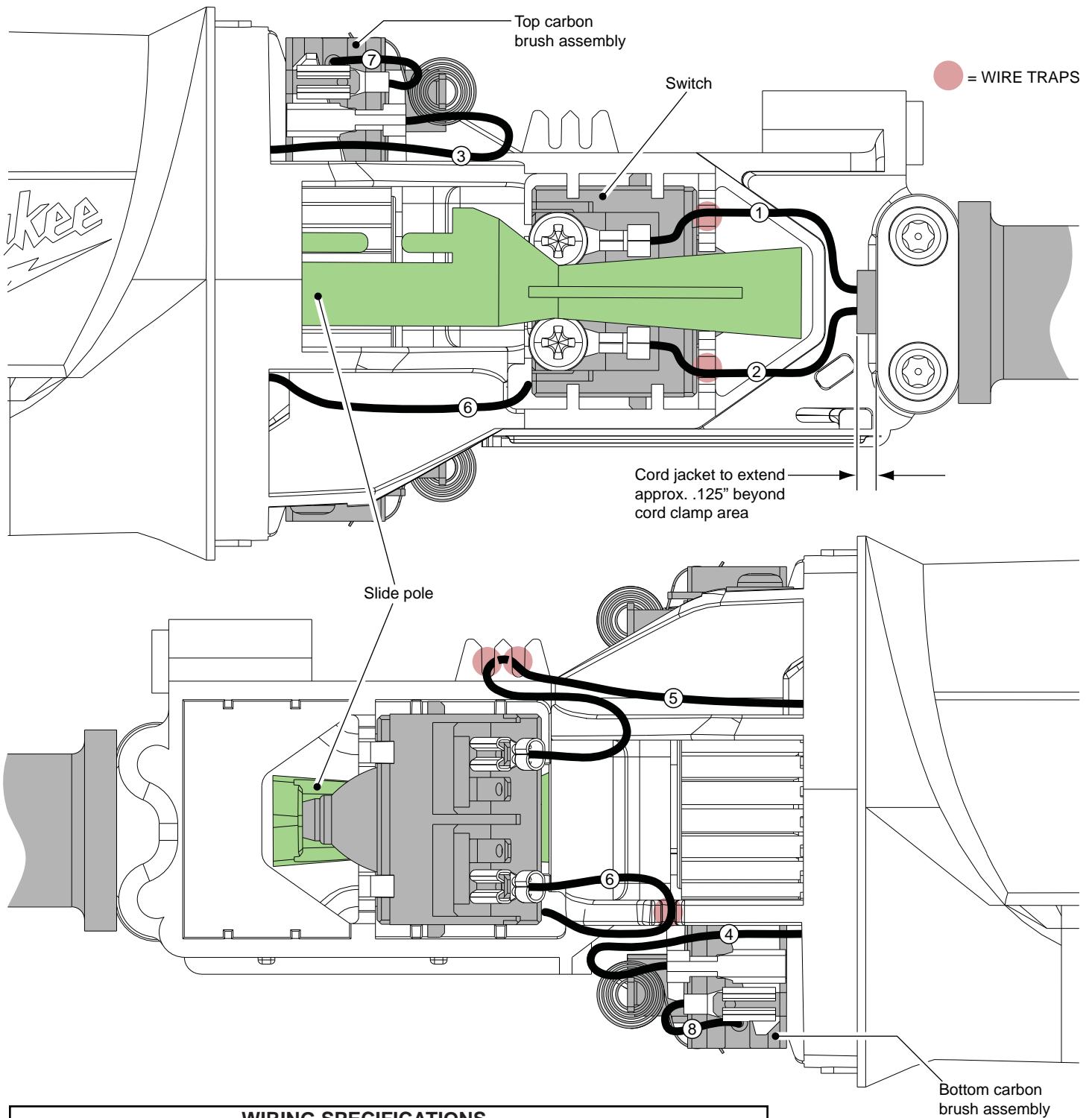

### WIRING SPECIFICATIONS

Wire No.	Wire Color	Origin or Gauge	Length	Terminals, Connectors and 1 or 2 End Wire Preparation
1	Black	----	----	Component of cord set 22-64-0565.
2	White	----	----	Component of cord set 22-64-0565.
3	Black	----	----	Component of field 18-07-0175.
4	Black	----	----	Component of field 18-07-0175.
5	Black	----	----	Component of field 18-07-0175.
6	Black	----	----	Component of field 18-07-0175.
7	----	----	----	Brush shunt. Component of carbon brush assembly 22-22-0085.
8	----	----	----	Brush shunt. Component of carbon brush assembly 22-22-0085.

AS AN AID TO REASSEMBLY, TAKE NOTICE OF WIRE ROUTING AND POSITION IN WIRE GUIDES AND TRAPS WHILE DISMANTLING TOOL.

BE CAREFUL AND AVOID PINCHING WIRES BETWEEN HANDLE HALVES WHEN ASSEMBLING.