



# SERVICE PARTS LIST

**BUL. 54-38-9201**

## 9" DISC SANDER

REVISED BUL. 6154-2      DATE Feb. '68  
WIRING INSTR.

**Catalog No. 6120**

Starting Serial No. **154-2125**

Both Model and Serial No. must be furnished to obtain correct parts.

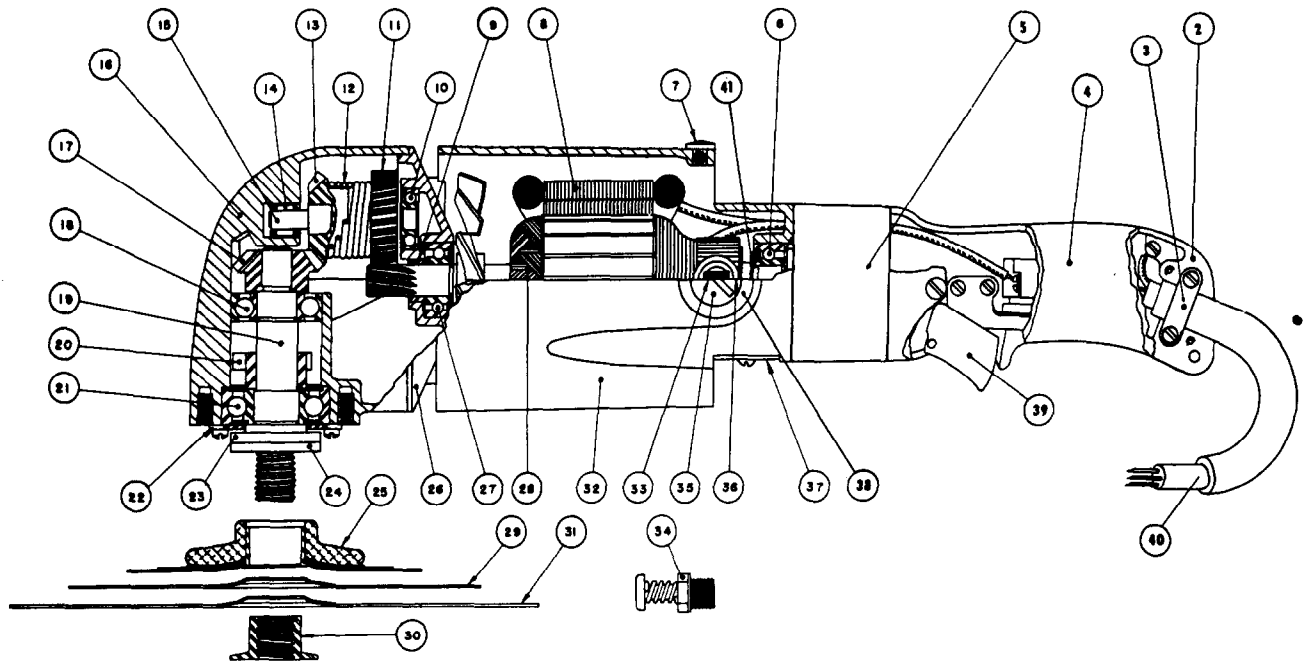

### ILLUSTRATED PARTS

FIG.	PART NO.	DESCRIPTION OF PART	FIG.	PART NO.	DESCRIPTION OF PART
2	28-44-1041	Handle (Switch Mounting Side)	22	45-88-0220	Ball Bearing Retaining Ring
3	28-17-0200	Cord Clamp Strap	23	45-88-0141	Hub Steel Washer
4	28-44-9081	Handle (Switch Cover Side)	24	45-88-0160	Hub Rubber Washer
5	23-62-0100	Radio Supp. System	25	48-80-0750	5" Flat Disc Hub Assembly
6	02-04-1070	Ball Bearing (Comm. End)	26	28-28-0381	Diaphragm
7	06-77-1400	Drive Screw Tool Rest Button	27	02-04-1340	Ball Bearing (Pinion End)
8	18-82-1170	Field Assembly	28	16-82-1710	Armature Assembly
9	45-28-0080	Grease Slinger	29	48-80-0900	7" Flat Backing Disc
10	02-04-0920	Ball Bearing	30	44-40-0120	Disc Nut (5/8-11 Thread)
11	32-40-1481	Intermediate Gear	31	48-80-1100	9" Flat Backing Disc
12	40-50-3200	Spindle Drive Spring	32	28-50-4562	Motor Housing
13	32-50-1241	Miter Gear (Sold only with 32-50-1261 as set) *	33	22-18-0260	Carbon Brush Assembly
14	02-50-2130	Needle Bearing	34	44-20-0060	Spindle Lock Assembly
15	36-66-3301	Intermediate Shaft	35	23-44-0065	Brush Retaining Cap
16	28-14-0601	Gear Case	*36	22-22-0130	Brush Holder Assembly (per set 2)
17	32-50-1261	Refer to Item 13	37	44-66-0100	Commutator Cover Plate
18	02-04-1710	Ball Bearing (Upper)	38	22-24-0100	Brush Holder Bushing Steel
19	38-50-1751	Spindle (5/8-11 Thread)	39	23-66-0250	Switch Assembly
20	42-74-0061	Spindle Lock Cog	*40	22-64-0280	Cord Set
21	02-04-2060	Ball Bearing (Lower)	41	43-06-0070	Grounding Disc

### MISCELLANEOUS PARTS NOT SHOWN

PART NO.	DESCRIPTION OF PART	PART NO.	DESCRIPTION OF PART
28-79-0241	Tool Rest	06-81-3750	8-32x1" Oval Hd. Handle Cover Screw
48-03-0010	Adapter Plug (3 Prong)	06-81-8650	6-32x1/4" Rd. Hd. Comm. Cover Plate Screw
12-98-3500	Name Plate	06-81-3700	8-32x7/8" Oval Hd. Handle Cover Screw
43-62-0141	Wooden Side Handle Assembly	06-81-6150	8-32x1/2" Fil. Hd. Cord Clamp Strap Screw
*23-86-0130	Insulating Washer (2)	06-81-5400	8-32x5/16" Binder Hd. Switch Mounting Screw
06-81-6950	10-24x1/2" Fil. Hd. Sem Tool Rest Screw (2)	*06-81-6750	8-32x2 1/2" Fil. Hd. Field Screw Sem
06-83-2650	1/4"-20x3/8" Hd. less Brush Holder Set Sc. (4)	06-81-8625	6-32x1/4" Rd. Hd. Sem Ground Screw (Brass)
06-81-1625	12-24x2-1/4" Fil. Hd. Switch Handle Sc. (4)	06-81-8200	4-36x3/16" Rd. Hd. Name Plate Screws Sem
06-81-7250	10-24x1-1/2" Fil. Hd. Gear Case Screws (4)	06-81-6050	8-32x5/16" Fil. Hd. Ret. Washer Screws Sem

Numbers in brackets indicate number required.