



# SERVICE PARTS LIST

**BULLETIN NO.**  
54-38-0201

SPECIFY CATALOG NO. AND SERIAL NO. WHEN ORDERING PARTS		REVISED BULLETIN 54-38-0200	DATE Jan. '85
<b>9" SANDER/GRINDER</b>			
<b>CATALOG NO. 6106</b>		<b>STARTING SERIAL NO. 654-5001</b>	
<b>WIRING INSTRUCTION</b> <b>58-01-0307</b>			
CAT. NO.	START SER. NO.	BILINGUAL LABEL	

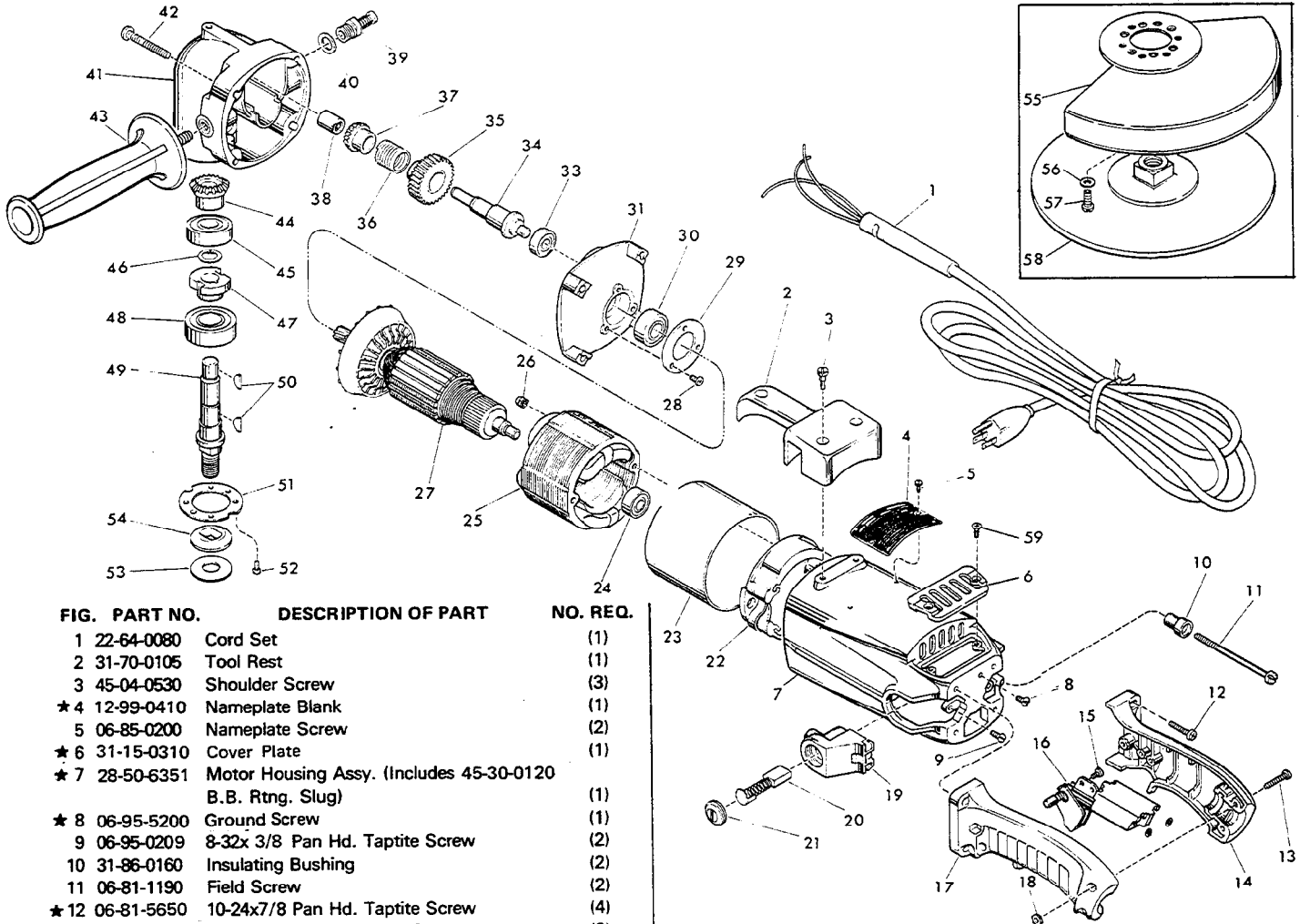

FIG.	PART NO.	DESCRIPTION OF PART	NO. REQ.
	1	22-64-0080 Cord Set	(1)
	2	31-70-0105 Tool Rest	(1)
	3	45-04-0530 Shoulder Screw	(3)
★	4	12-99-0410 Nameplate Blank	(1)
	5	06-85-0200 Nameplate Screw	(2)
★	6	31-15-0310 Cover Plate	(1)
★	7	28-50-6351 Motor Housing Assy. (Includes 45-30-0120 B.B. Rtnng. Slug)	(1)
★	8	06-95-5200 Ground Screw	(1)
	9	06-95-0209 8-32x 3/8 Pan Hd. Taptite Screw	(2)
	10	31-86-0160 Insulating Bushing	(2)
	11	06-81-1190 Field Screw	(2)
★	12	06-81-5650 10-24x7/8 Pan Hd. Taptite Screw	(4)
	13	06-81-4207 10-24x7/8 Phil. Pan. Hd. Screw	(3)
	14	31-44-0580 Right Handle Half	(1)
	15	06-95-0215 8-18x1/2 Pan Hd. Thread Form Screw	(1)
	16	23-66-0255 Switch (Use (4) 06-97-1800 Lockwashers)	(1)
★	17	31-44-0605 Left Handle Half	(1)
	18	06-55-1000 10-24 Hex Nut	(3)
★	19	22-22-0400 Brush Holder Assy. (Includes 22-20-0360 Brush Tube)	(2)
	20	22-18-0145 Carbon Brush Assembly	(2)
	21	23-44-0140 Brush Retaining Screw	(2)
	22	31-55-0110 Coil Shield	(1)
	23	23-16-0950 Insulating Sleeve	(1)
	24	02-04-0911 Ball Bearing	(1)
	25	18-70-0025 120 Volt Field	(1)
	26	06-57-3005 10-32 Locking Hex Nut	(2)
★	27	16-70-0215 120 Volt Armature (W/34-60-1315 Rtnng. Ring)	(1)
	28	06-95-0209 8-32x 3/8 Taptite Screw	(3)
	29	44-86-0320 Ball Bearing Retainer	(1)
	30	02-04-1516 Ball Bearing	(1)
	31	28-28-0391 Diaphragm Assy. (Includes 45-30-0120 B.B. Rtnng. Slug)	(1)
	33	02-04-0910 Ball Bearing	(1)
	34	36-66-3310 Intermediate Shaft	(1)
★	35	32-40-1930 Intermediate Gear	(1)
	36	40-50-3200 Clutch Spring	(1)

FIG.	PART NO.	DESCRIPTION OF PART	NO. REQ.
	37	32-05-1120 Bevel Gear	(1)
	38	02-50-2441 Needle Bearing	(1)
	39	44-20-0060 Spindle Lock Assembly	(1)
	40	45-88-5320 Flat Washer	(1)
	41	28-14-0615 Gear Case Assembly	(1)
★	42	06-95-5655 1/4-20x1-3/4 Taptite Screw	(4)
★	43	43-62-0880 Side Handle Assembly	(1)
	44	32-05-1130 Bevel Gear	(1)
	45	02-04-1746 Ball Bearing	(1)
	46	34-60-1290 Retaining Ring	(1)
	47	42-74-0070 Spindle Locking Cog	(1)
	48	02-04-2031 Ball Bearing	(1)
	49	38-50-5205 Spindle Shaft	(1)
	50	06-42-1600 Woodruff Key	(2)
	51	45-88-0220 Spindle Retaining Washer	(2)
	52	06-95-3226 8-32x3/8 Fil. Hd. Taptite Screw	(3)
	53	45-88-0160 Spindle Rubber Washer	(1)
	54	49-05-0060 Rubber Washer Flange	(1)
★	55	49-12-0340 9" Disc Guard (Incl. Fig. Nos. 56 & 57)	(1)
★	56	06-97-4000 Lockwasher	(2)
★	57	06-95-5630 1/4-20 x 1/2" Special Screw	(2)
	58	9" Abrasive Disc (Select from Catalog)	
★	59	06-95-3601 8-32 x 3/8" Oval Hd. Taptite Screw	(2)

**MILWAUKEE ELECTRIC TOOL CORPORATION**  
13135 W. LISBON RD., BROOKFIELD, WIS. 53005