

SERVICE PARTS LIST



SPECIFY CATALOG NO. AND SERIAL NO. WHEN ORDERING PARTS		REVISED BULLETIN	DATE
7" GRINDER - 8000 R.P.M.			May '91
CATALOG NO. 6098-2	STARTING SERIAL NO. 721-1001	WIRING INSTRUCTION 58-01-0307	

EXAMPLE:

00	0
----	---

 Component Parts (Small #) Are Included
 When Ordering The Assembly (Large #).

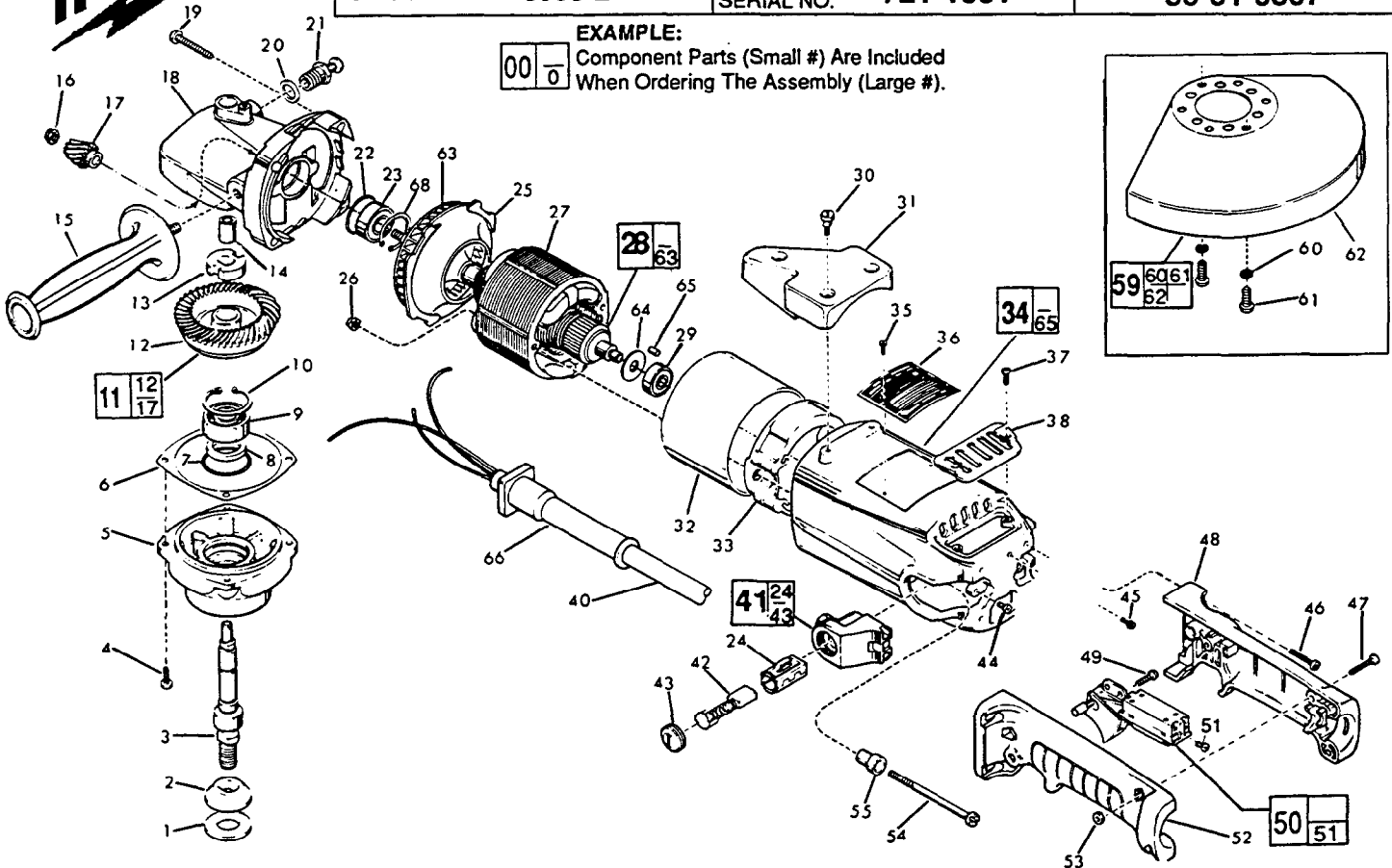

FIG.	PART NO.	DESCRIPTION OF PART	NO. REQ.
1	45-88-0160	Spindle Washer - Rubber	(1)
2	49-05-0060	Washer Flange	(1)
3	38-50-5560	Spindle Shaft	(1)
4	06-82-8864	10-24 x 1/2" Pan Hd. Sems T-25 Screw	(4)
5	28-14-1735	Lower Gear Case	(1)
6	45-14-0225	Shim - Blue .005 Thick	(1)
7	45-14-0210	Shim - Red .010 Thick	(1)
8	34-40-1610	O-Ring	(1)
9	45-06-0330	Felt Seal	(1)
10	02-04-1746	Ball Bearing	(1)
11	34-80-2960	Retaining Ring - Internal	(1)
12	14-46-4310	Bevel Gear Kit	(1)
13	32-05-2211	Spiral Bevel Gear	(1)
14	42-74-0080	Spindle Locking Cog	(1)
15	02-50-2428	Needle Bearing	(1)
16	43-62-0880	Side Handle	(1)
17	06-57-5006	1/4 - 28 Locking Hex Nut	(1)
18	32-60-1296	Spiral Bevel Pinion	(1)
19	28-14-2035	Upper Gear Case	(1)
20	06-82-5716	1/4-20 x 1-1/4" Pan Hd. T-30 Taptite Screw	(4)
21	45-88-5320	Flat Washer	(1)
22	44-20-0235	Spindle Lock Assembly	(1)
23	34-40-1375	O-Ring	(1)
24	02-04-1229	Ball Bearing	(1)
25	22-20-0360	Brush Tube	(2)
26	42-14-0300	Baffle	(1)
27	06-57-3005	10-32 Locking Hex Nut	(2)
28	18-76-0260	240 Volt Field	(1)
29	16-76-0300	240 Volt Armature	(1)
30	02-04-0911	Ball Bearing	(1)
31	45-04-0720	Shoulder Screw	(3)
32	31-70-0150	Tool Rest	(1)
33	23-16-0950	Insulating Sleeve	(1)
34	31-55-0110	Coil Shield	(1)
35	28-50-6351	Motor Housing	(1)
36	06-85-0200	Nameplate Screw	(2)
37	12-99-0406	Nameplate Blank	(1)
38	06-95-3601	8-32 x 3/8" Oval Hd. Taptite Screw	(2)
	31-15-0310	Cover Plate	(1)

FIG.	PART NO.	DESCRIPTION OF PART	NO. REQ.
40	22-64-4510	Cord Set	(1)
41	22-22-0401	Brush Holder Assembly	(2)
42	22-18-0770	Carbon Brush Assembly	(2)
43	23-44-0170	Brush Retaining Cap	(2)
44	06-82-7252	8-32 x 3/8" Pan Hd. T-20 Screw	(2)
45	06-95-5200	8-32 x 5/16" Slot Hex Hd. Screw	(1)
46	06-82-5574	10-24 x 7/8" Pan Hd. T-25 Taptite Screw	(4)
47	06-82-2378	10-24 x 1" Pan Hd. T-25 Screw	(3)
48	31-44-0606	Right Handle Half	(1)
49	06-82-7409	8-16 x 1/2" Pan Hd. T-20 Plastite Screw	(1)
50	23-66-1800	Switch	(1)
51	05-78-0305	Switch Screw T-15	(4)
52	31-44-0607	Left Handle Half	(1)
53	06-55-1050	10-24 Hex Nut	(3)
54	06-82-9600	10-32 x 3" Torx Hd. Screw	(2)
55	31-86-0160	Insulating Bushing	(2)
59	49-12-0350	7" Wheel Guard Assembly	(1)
60	06-97-4000	1/4" Split Ring Lockwasher	(2)
61	06-95-5630	1/4-20 x 1/2" Special Screw	(2)
62	43-54-0535	7" Wheel Guard	(1)
63	22-84-0800	Fan	(1)
64	45-06-0390	Dust Seal	(1)
65	45-30-0070	Ball Bearing Retaining Slug	(1)
66	44-76-0170	Cord Protector	(1)
68	34-80-2600	Internal Retaining Ring	(1)

- FIG. NOTES
 6 As Required (Max. .015").
 13 Dimple Side To Fig. 12.
 FIG. LUBRICATION
 18 2 Oz. Type "G" Grease, No. 49-08-4140.