



SERVICE PARTS LIST

BULLETIN NO.

54-38-0331

SPECIFY CATALOG NO. AND SERIAL NO. WHEN ORDERING PARTS

9" SANDER - 5000 R.P.M.

REVISED BULLETIN

54-38-0330

DATE

Nov. '88

CATALOG NO. 6095

STARTING SERIAL NO.

699-39451

WIRING INSTRUCTION

58-01-0901

EXAMPLE:



Component Parts (Small #) Are Included When Ordering The Assembly (Large #).

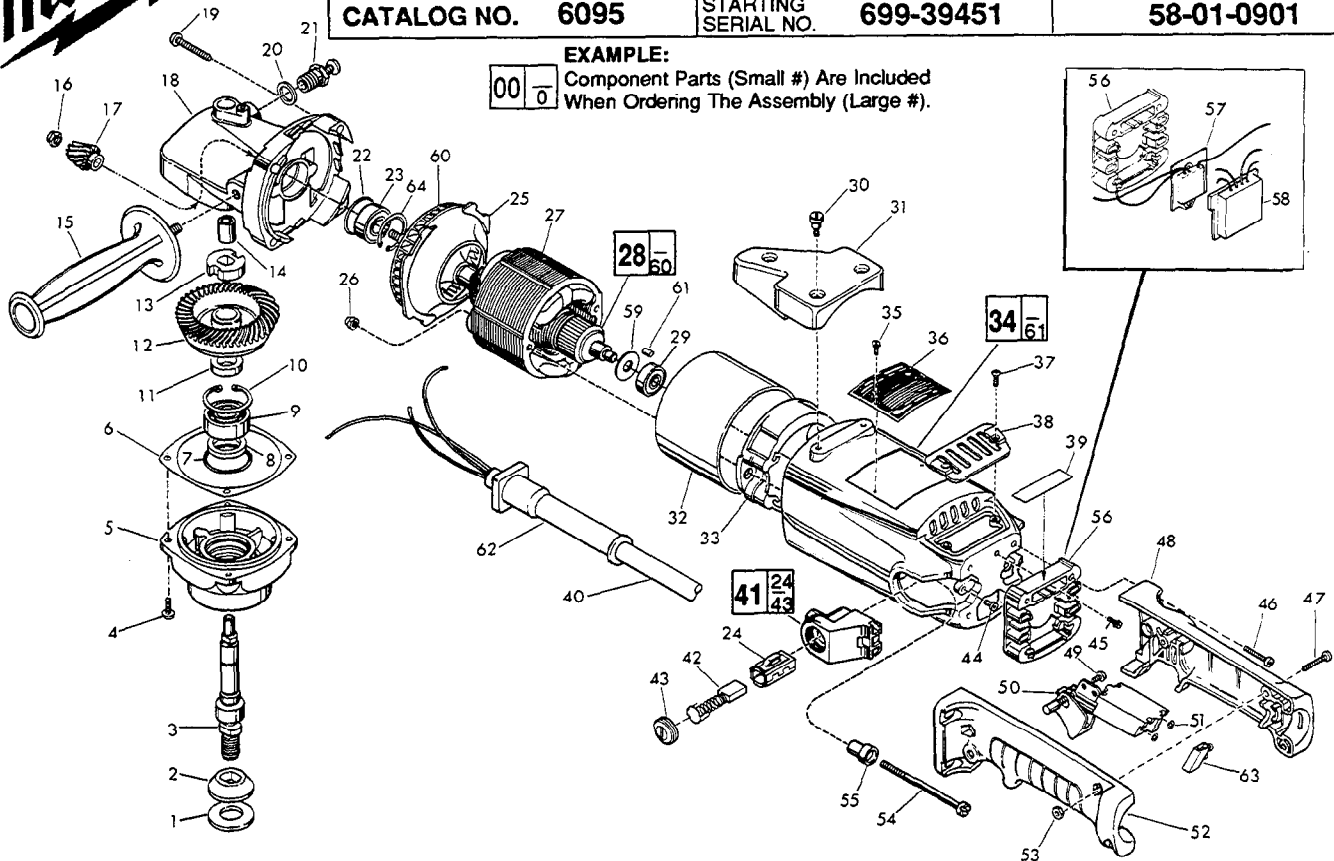

FIG.	PART NO.	DESCRIPTION OF PART	NO. REQ.
	1	45-88-0160 Spindle Washer - Rubber	(1)
	2	49-05-0060 Washer Flange	(1)
	3	38-50-5560 Spindle Shaft	(1)
★	4	06-82-8864 10-24 x 1/2" Pan Hd. Torx Sems Screw	(4)
	5	28-14-1735 Lower Gear Case	(1)
	6	45-14-0225 Shim - Blue .005 Thick	(1)
	7	45-14-0210 Shim - Red .010 Thick	(1)
	8	34-40-1610 O-Ring	(1)
	9	45-06-0330 Felt Seal	(1)
	9	02-04-1746 Ball Bearing	(1)
	10	34-80-2960 Retaining Ring - Internal	(1)
	11	45-36-1250 Spacer	(1)
	12	32-05-2190 Spiral Bevel Gear	(1)
	13	42-74-0080 Spindle Locking Cog	(1)
	14	02-50-2428 Needle Bearing	(1)
	15	43-62-0880 Side Handle	(1)
	16	06-57-5006 1/4 - 28 Locking Hex Nut	(1)
	17	32-60-1285 Spiral Bevel Pinion	(1)
★	18	28-14-2035 Upper Gear Case	(1)
	19	06-82-5716 1/4-20 x 1-1/4" Pan Hd. Torx Taptite Screw	(4)
	20	45-88-5320 Flat Washer	(1)
	21	44-20-0235 Spindle Lock Assembly	(1)
	22	34-40-1375 O-Ring	(1)
	23	02-04-1230 Ball Bearing	(1)
	24	22-20-0360 Brush Tube	(2)
	25	42-14-0300 Baffle	(1)
	26	06-57-3005 10-32 Locking Hex Nut	(2)
	27	18-70-0260 120 Volt Field	(1)
★	28	16-70-0300 120 Volt Armature	(1)
	29	02-04-0911 Ball Bearing	(1)
	30	45-04-0570 Shoulder Screw	(3)
	31	31-70-0150 Tool Rest	(1)
	32	23-16-0950 Insulating Sleeve	(1)
	33	31-55-0110 Coil Shield	(1)
	34	28-50-6351 Motor Housing	(1)
	35	06-85-0200 Nameplate Screw	(2)
	36	12-99-0405 Nameplate Blank	(1)
	37	06-95-3601 8-32 x 3/8" Oval Hd. Taptite Screw	(2)
	38	31-15-0310 Cover Plate	(1)

FIG.	PART NO.	DESCRIPTION OF PART	NO. REQ.
	39	12-98-7270 Instruction Plate	(1)
★	40	22-64-3000 Cord Set	(1)
	41	22-22-0401 Brush Holder Assembly	(2)
	42	22-18-0145 Carbon Brush Assembly	(2)
	43	23-44-0170 Brush Retaining Cap	(2)
	44	06-82-7252 8-32 x 3/8" Pan Hd. Screw	(2)
	45	06-95-5200 8-32 x 5/16" Slot Hex Hd. Screw	(1)
	46	06-82-5584 10-24 x 1-3/8" Pan Hd. Torx Taptite Screw	(4)
★	47	06-82-2378 10-24 x 1" Pan Hd. Torx Screw	(3)
★	48	31-44-0606 Right Handle Half	(1)
	49	06-82-7409 8-16 x 1/2" Pan Hd. Torx Plastite Screw	(1)
	50	23-66-0255 Switch	(1)
	51	06-97-1800 Switch Lockwasher - No. 6 Internal Tooth	(4)
★	52	31-44-0607 Left Handle Half	(1)
	53	06-55-1050 10-24 Hex Nut	(3)
	54	06-81-1170 10-32 x 3" Flat Fil. Hd. Screw	(2)
	55	31-86-0160 Insulating Bushing	(2)
	56	31-86-0190 Insulating Spacer (See Insert)	(1)
	57	14-20-0210 Power Module Assembly	(1)
	58	14-20-0200 Control Module Assembly	(1)
	59	45-06-0390 Dust Seal	(1)
	60	22-84-0800 Fan	(1)
	61	45-30-0070 Ball Bearing Retaining Slug	(1)
★	62	44-76-0170 Cord Protector	(1)
★	63	22-56-0480 Terminal Block	(1)
★	64	34-80-2600 Internal Retaining Ring	(1)

FIG. NOTES

- 6 As Required (Max. .015").
- 13 Dimple Side To Fig. 12.

FIG. LUBRICATION

- 18 2 Oz. Type "G" Grease, No. 49-08-4140.

MILWAUKEE ELECTRIC TOOL CORPORATION
13135 W. LISBON RD., BROOKFIELD, WI 53005