



SERVICE PARTS LIST

BULLETIN NO.
54-38-0330

SPECIFY CATALOG NO. AND SERIAL NO. WHEN ORDERING PARTS		REVISED BULLETIN	DATE
9" SANDER - 5000 R.P.M.			Sept.'87
CATALOG NO. 6095	STARTING SERIAL NO. 699-1001	WIRING INSTRUCTION 58-01-0901	

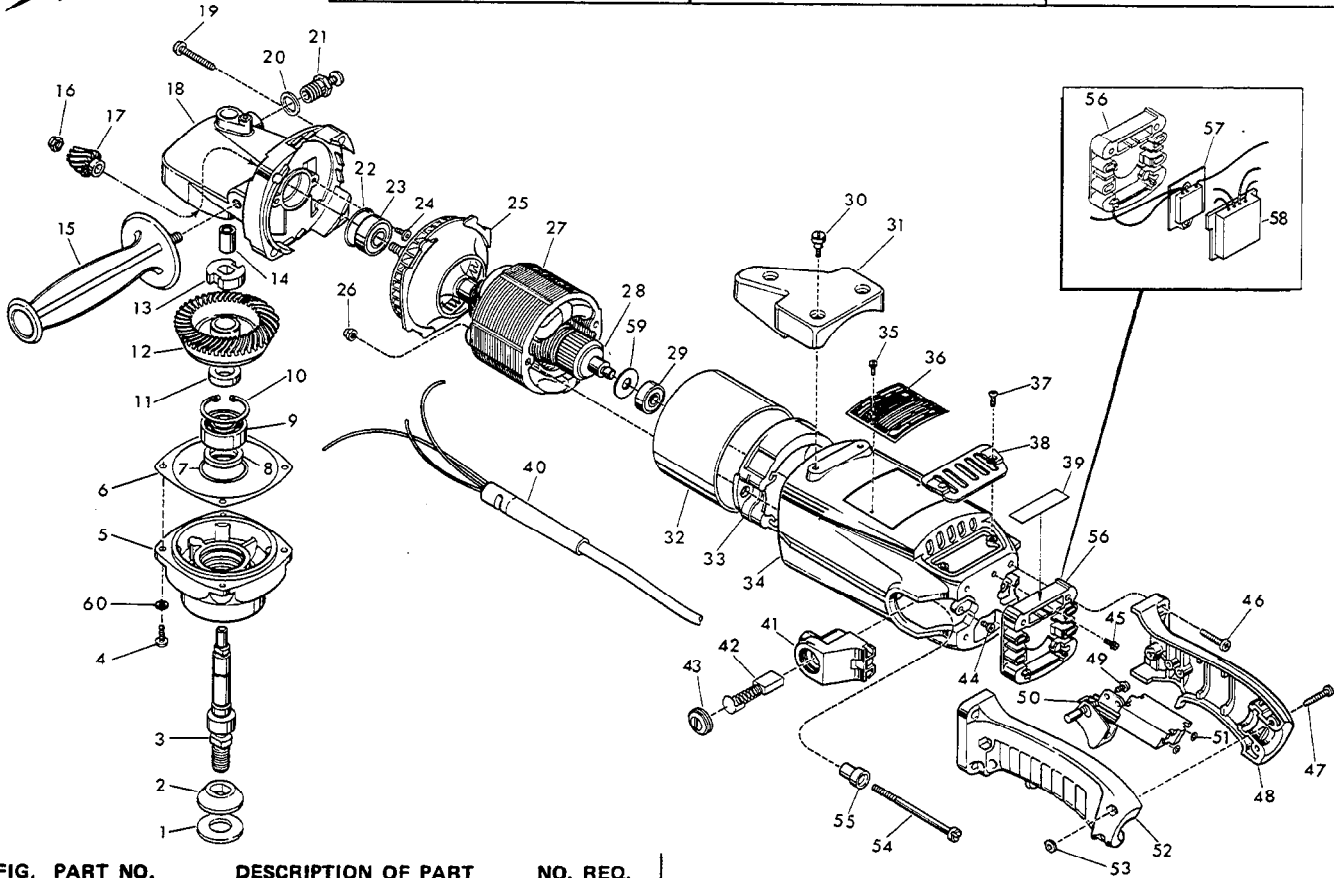

FIG. PART NO. DESCRIPTION OF PART NO. REQ.

1	45-88-0180	Spindle Washer - Rubber	(1)
2	49-05-0060	Washer Flange	(1)
3	38-50-5560	Spindle Shaft	(1)
4	06-82-5566	10-24 x 1/2" Pan Hd. Torx Taptite Screw	(4)
5	28-14-1735	Lower Gear Case	(1)
6	45-14-0225	Shim - Blue .005 Thick (See Note)	(1)
7	34-40-1610	O-Ring	(1)
8	45-06-0330	Felt Seal	(1)
9	02-04-1746	Ball Bearing	(1)
10	34-80-2960	Retaining Ring - Internal	(1)
11	45-36-1250	Spacer	(1)
12	32-05-2190	Spiral Bevel Gear	(1)
13	42-74-0080	Spindle Locking Cog (Dimple Side to Fig. 12)	(1)
14	02-50-2428	Needle Bearing	(1)
15	43-62-0880	Side Handle	(1)
16	06-57-5006	1/4 - 28 Locking Hex Nut (See Note)	(1)
17	32-60-1285	Spiral Bevel Pinion	(1)
18	28-14-1745	Upper Gear Case	(1)
19	06-82-5716	1/4-20 x 1-1/4 Pan Hd. Torx Taptite Screw	(4)
20	45-88-5320	Flat Washer	(1)
21	44-20-0235	Spindle Lock Assembly	(1)
22	34-40-1375	O-Ring	(1)
23	02-04-1230	Ball Bearing	(1)
24	06-82-5522	8-32 x .328 Pan Hd. Torx Taptite Screw	(2)
25	42-14-0300	Baffle	(1)
26	06-57-3005	10-32 Locking Hex Nut	(2)
27	18-70-0260	120 Volt Field	(1)
28	16-70-0260	120 Volt Armature (Incl. 22-84-0800 Fan)	(1)
29	02-04-0911	Ball Bearing	(1)
30	45-04-0570	Shoulder Screw	(3)
31	31-70-0150	Tool Rest	(1)
32	23-16-0950	Insulating Sleeve	(1)
33	31-55-0110	Coil Shield	(1)
34	28-50-6351	Motor Housing (Incl. 45-30-0120 Slug)	(1)
35	06-85-0200	Nameplate Screw	(2)

FIG. PART NO. DESCRIPTION OF PART NO. REQ.

36	12-99-0405	Nameplate Blank	(1)
37	06-95-3601	8-32 x 3/8" Oval Hd. Taptite Screw	(2)
38	31-15-0310	Cover Plate	(1)
39	12-98-7270	Instruction Plate	(1)
40	22-64-0076	Cord Set	(1)
41	22-22-0401	Brush Holder Assy. (Coarse Thread) Includes 22-20-0360 Brush Tube & 23-44-0170 Brush Cap	(2)
	22-22-0400	Brush Holder Assy. (Previous Fine Thread Assy.) Incl. 22-20-0360 Brush Tube	(2)
42	22-18-0145	Carbon Brush Assembly	(2)
43	23-44-0170	Brush Retaining Cap - Coarse Thread	(2)
	23-44-0140	Brush Retaining Cap - Fine Thread	(2)
44	06-82-7252	8-32 x 3/8" Pan Hd. Screw	(2)
45	06-95-5200	8-32 x 5/16" Slot Hex Hd. Screw	(1)
46	06-82-5584	10-24 x 1-3/8" Pan Hd. Torx Taptite Screw	(4)
47	06-82-2568	10-24 x 7/8" Pan Hd. Torx Screw	(3)
48	31-44-0580	Right Handle Half	(1)
49	06-82-7409	8-16 x 1/2" Pan Hd. Torx Plastite Screw	(1)
50	23-66-0255	Switch	(1)
51	06-97-1800	Switch Lockwasher - No. 6 Internal Tooth	(4)
52	31-44-0605	Left Handle Half	(1)
53	06-55-1050	10-24 Hex Nut	(3)
54	06-81-1170	10-32 x 3" Flat Fil. Hd. Screw	(2)
55	31-86-0160	Insulating Bushing	(2)
56	31-86-0190	Insulating Spacer (See Insert)	(1)
57	14-20-0210	Power Module - Assembly	(1)
58	14-20-0200	Control Module Assembly	(1)
59	45-06-0390	Dust Seal	(1)
60	06-97-3500	No. 10 Split Ring Lockwasher	(4)

NOTES
Fig. No. 6 - As Required (Max. .015")

LUBRICATION
1-1/2 oz. - Type "G" Grease