

Parts Breakdown for the 22-44 Open Stand

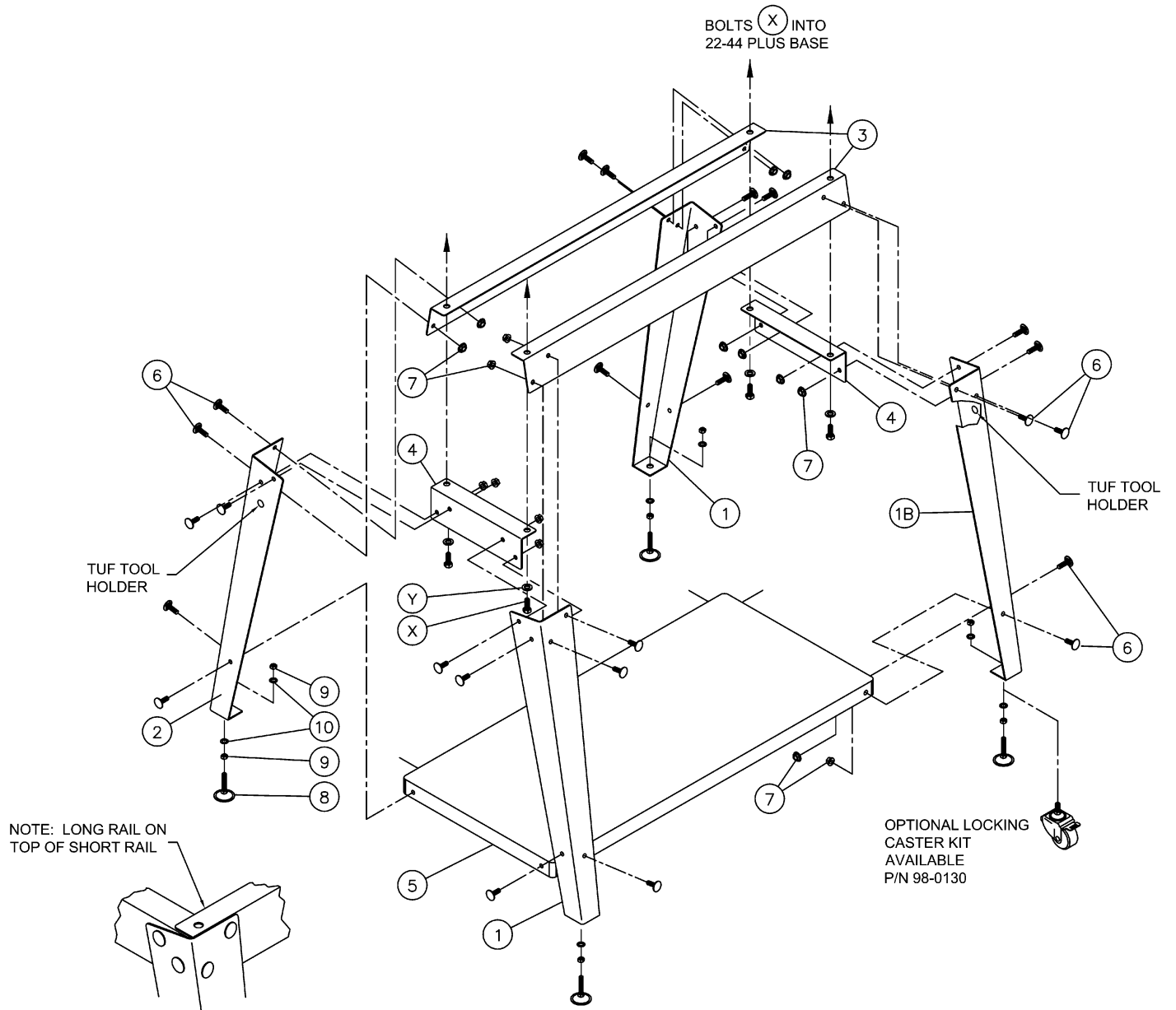

Index No.	Part No.	Description	Size	Qty.
1.....	40-4040.....	Leg, Left		2
2.....	40-4041.....	Leg, Right (with TUF tool holder).....		2
3.....	2244PLUS-303.....	Rail, Long		2
4.....	2244PLUS-304.....	Rail, Short.....		2
5.....	2244PLUS-305.....	Shelf		1
6.....	10-1206.....	Carriage Bolt.....	5/16-18x5/8"	24
7.....	12-0207.....	Nut, Flanged Lock.....	5/16"	24
8.....	20-0655.....	Leveling Foot.....		4
9.....	12-0005.....	Hex Nut	3/8"-16	8
10.....	11-9103.....	Flat Washer	3/8	8