



# SERVICE PARTS LIST

**BULLETIN NO.**  
54-38-1275

SPECIFY CATALOG NO. AND SERIAL NO. WHEN ORDERING PARTS			REVISED BULLETIN	DATE
<b>DETAIL SANDER</b>				Nov. '98
<b>CATALOG NO. 6035-20</b>	STARTING SERIAL NUMBER	<b>903A997090001-903A997282000</b>	WIRING INSTRUCTION	

00 0

EXAMPLE:  
Component Parts (Small #) Are Included  
When Ordering The Assembly (Large #).

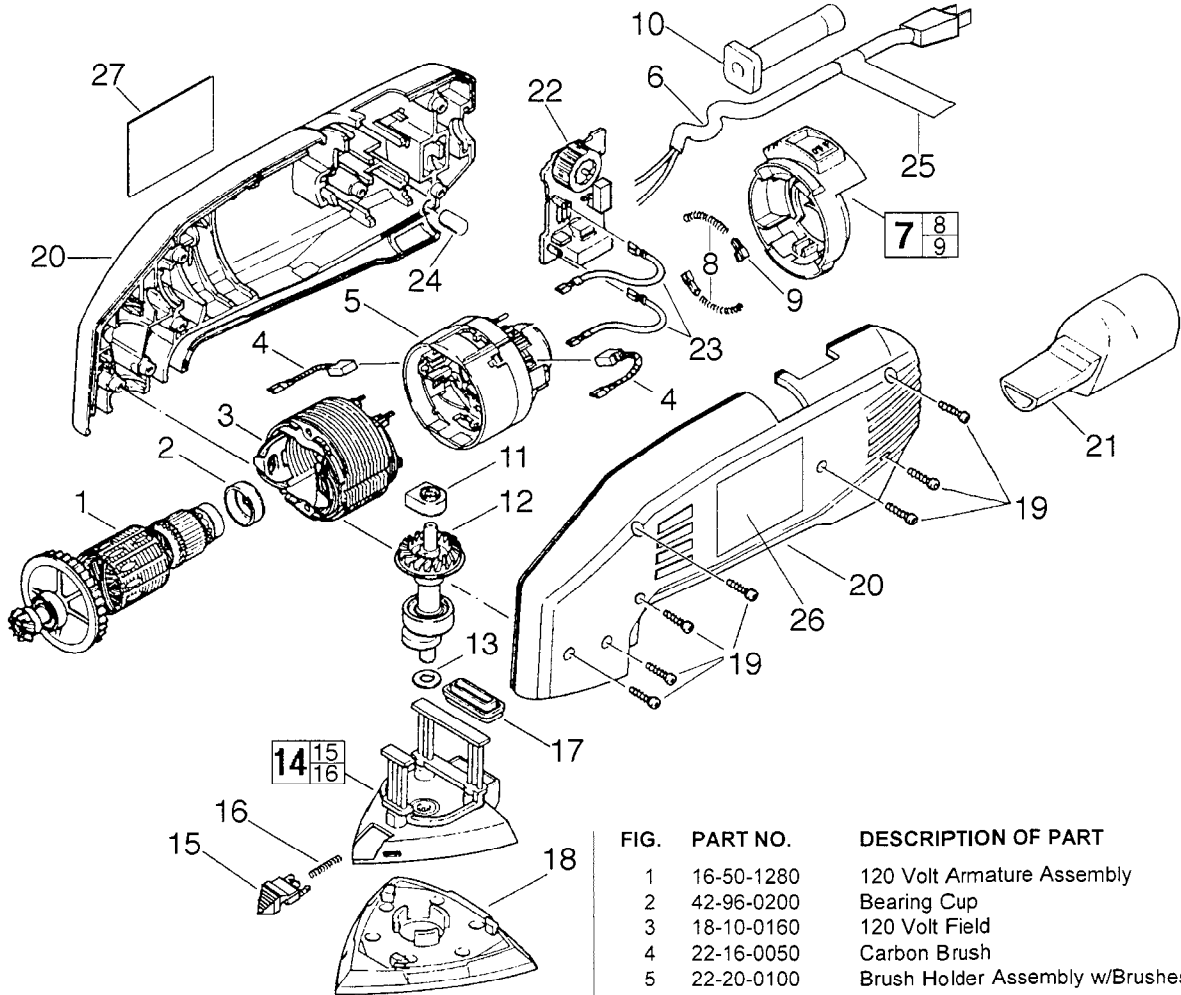

**FIG. LUBRICATION**

- 11,14 Apply Type "N" Grease, No. 49-08-4230, in the needle bearing opening of the quik-lok base plate and inside the opening of the insert/bearing assembly.
- 12 Evenly apply 3 grams of Type "N" Grease, No. 49-08-4230, on the gear teeth of the drive shaft assembly.

**FIG. NOTES:**

- 19 Torque to 15-18 in./lbs.
- 14 Screws on the bottom of the quik-lok base plate (not for sale) should be torqued to 4-6 in./lbs.

FIG.	PART NO.	DESCRIPTION OF PART	QTY
1	16-50-1280	120 Volt Armature Assembly	(1)
2	42-96-0200	Bearing Cup	(1)
3	18-10-0160	120 Volt Field	(1)
4	22-16-0050	Carbon Brush	(2)
5	22-20-0100	Brush Holder Assembly w/Brushes	(1)
6	22-64-0840	Cord	(1)
7	23-66-0040	Switch	(1)
8	40-50-0230	Spring	(2)
9	30-58-0065	Spring Adapter	(2)
★ 10	44-76-0115	Cord Protector	(1)
11	02-50-2035	Insert/Bearing Assembly	(1)
12	38-50-6110	Drive Shaft Assembly	(1)
13	45-88-7380	Felt Ring	(1)
14	42-20-0085	Quik-Lok Base Plate	(1)
15	42-42-0475	Release Button	(1)
16	40-50-0225	Spring	(1)
17	43-87-0090	Dust Bellow	(1)
18	49-36-7090	Sanding Pad	(1)
19	06-95-6310	Screw	(7)
★ 20	43-76-0656	Housings (1 pr.)	(1)
21	49-90-2060	Vacuum Adapter	(1)
22	14-20-0100	Speed Dial Assembly	(1)
23	23-94-0110	Lead Wire	(2)
24	44-60-1080	Rubber Slug	(1)
25	10-15-0375	Warning Label	(1)
26	10-15-1145	Milwaukee Logo Label	(1)
27	12-20-6035	Service Nameplate Kit	(1)