



SERVICE PARTS LIST

7" DISC SANDER

Catalog No. **6032**

Starting Serial No. **531-4700**

BUL. 54-38-2501

REVISED BUL. 54-38-2500 DATE Dec. '78

WIRING INSTRUCTIONS 58-01-0506

Specify Catalog and Serial No. when ordering parts

3000 R.P.M.

9 AMPS

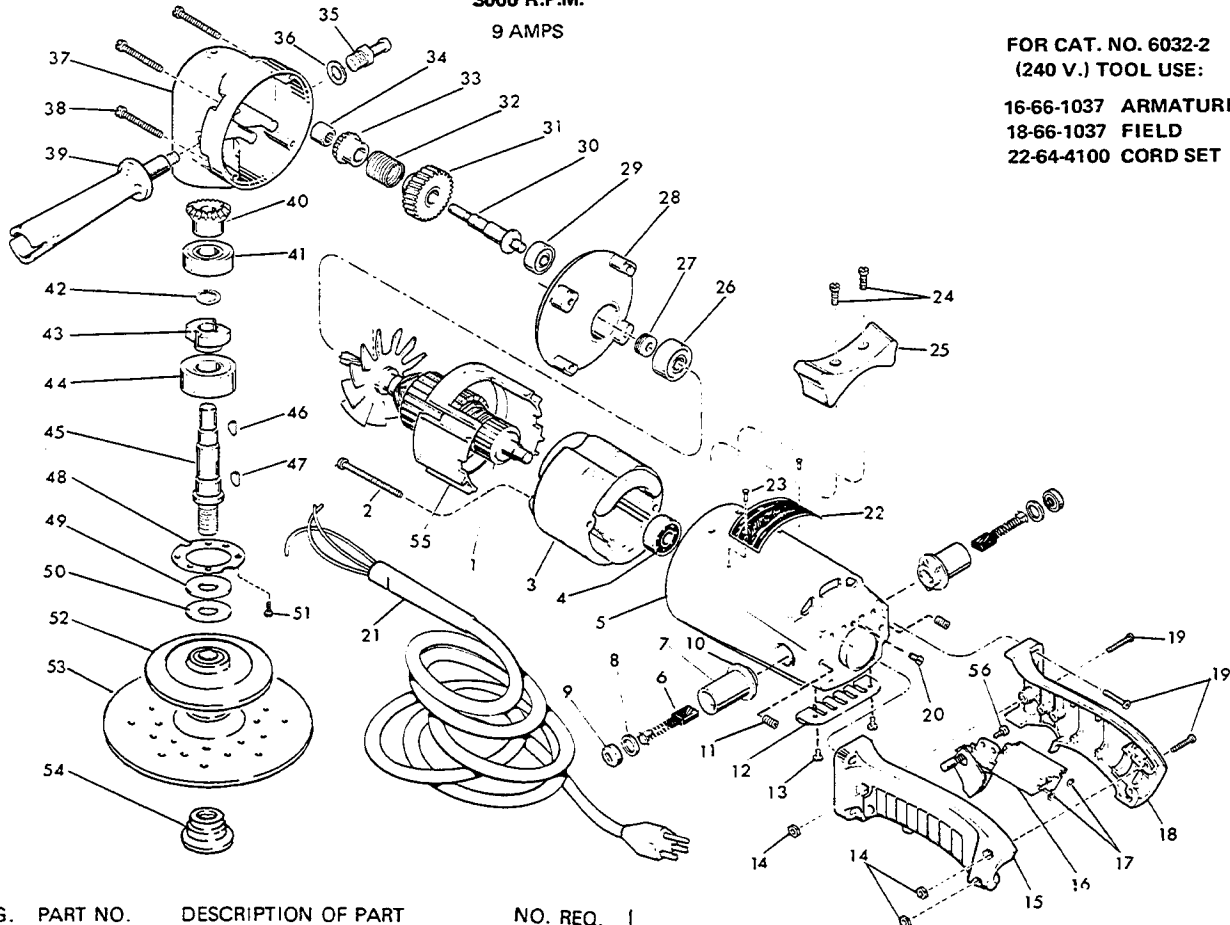

FOR CAT. NO. 6032-2
(240 V.) TOOL USE:

16-66-1037 ARMATURE
18-66-1037 FIELD
22-64-4100 CORD SET

FIG.	PART NO.	DESCRIPTION OF PART	NO. REQ.
★ 1	16-62-1037	120 Volt Armature	(1)
2	06-81-8950	8-32x2-1/4 Rd. Hd. Sem	(2)
★ 3	18-62-1037	120 Volt Field	(1)
4	02-04-0970	Ball Bearing	(1)
★ 5	28-50-5101	Motor Housing	(1)
6	22-18-0175	Carbon Brush Assembly	(1)
7	22-22-1231	Brush Holder	(2)
8	43-44-0180	Brush Cap Gasket	(2)
9	23-44-0100	Brush Retaining Screw	(2)
10	23-86-0075	Insulating Washer	(2)
11	06-83-2000	10-24x1/4 Set Screw	(2)
12	44-66-0230	Commutator Cover Plate	(1)
13	06-81-8650	6-32x1/4 Rd. Hd. Sem	(2)
14	06-55-1000	10-24 Hex Nut	(3)
15	31-44-0590	Handle Half Left	(1)
16	23-66-0255	Switch (20 Amp)	(1)
17	06-97-1800	Lockwasher	(4)
18	31-44-0580	Handle Half Right	(1)
19	06-81-4207	10-24x7/8 Phillips Pan Hd. Screw	(7)
★ 20	06-81-8800	8-32x1/4" Rd. Hd. Sem	(1)
21	22-64-0080	Cord Set	(1)
22	12-99-0032	Nameplate Blank	(1)
23	06-85-0200	Nameplate Screw	(2)
24	06-81-6950	10-24x1/2 Fil. Hd. Sem	(2)
25	28-79-0321	Tool Rest	(1)
26	02-04-1260	Ball Bearing	(1)
27	45-28-0060	Grease Slinger	(1)
28	28-28-0981	Diaphragm	(1)
29	02-04-0910	Ball Bearing	(1)

FIG.	PART NO.	DESCRIPTION OF PART	NO. REQ.
30	36-66-3251	Intermediate Shaft	(1)
31	32-40-1311	Intermediate Gear	(1)
32	40-50-3100	Drive Spring	(1)
33	32-05-1101	Bevel Gear	(1)
34	02-50-1630	Needle Bearing	(1)
35	44-20-0060	Spindle Lock Assembly	(1)
36	45-88-5320	Flat Washer	(1)
37	28-14-1082	Gear Case	(1)
38	06-81-7300	10-24x1-3/4 Fil. Hd. Sem	(4)
39	43-62-0570	Side Handle	(1)
40	32-05-1081	Bevel Gear	(1)
41	02-04-1710	Ball Bearing	(1)
42	34-60-1290	Retaining Ring	(1)
43	42-74-0065	Spindle Lock Cog	(1)
44	02-04-2065	Ball Bearing	(1)
45	38-50-3751	Spindle	(1)
46	06-42-1200	Woodruff Key	(1)
47	06-42-1600	Woodruff Key	(1)
48	45-88-0220	Spindle Retaining Washer	(1)
49	45-88-0141	Hub Thrust Washer	(1)
50	45-88-0160	Spindle Rubber Washer	(1)
51	06-81-6050	8-32x5/16 Fil. Hd. Sem	(6)
52	49-36-3500	Rubber Pad	(1)
53	48-80-6000	7" Phenolic Disc	(1)
54	49-40-0350	Disc Nut	(1)
★ 55	31-05-0100	Baffle	(1)
★ 56	06-95-0215	8-18x1/2 Pan Hd. Thread Form Screw	(1)
57	12-98-7081	Caution Plate (Not Shown)	(1)