



# SERVICE PARTS LIST

**BUL.54-38-2016**

## 7" DISC SANDER

REVISED BUL 649-7      DATE April '68

**Catalog No. 6020**

Starting Serial No. **49-24532**

WIRING INSTR. **58-01-0310**

Both Model and Serial No. must be furnished to obtain correct parts.

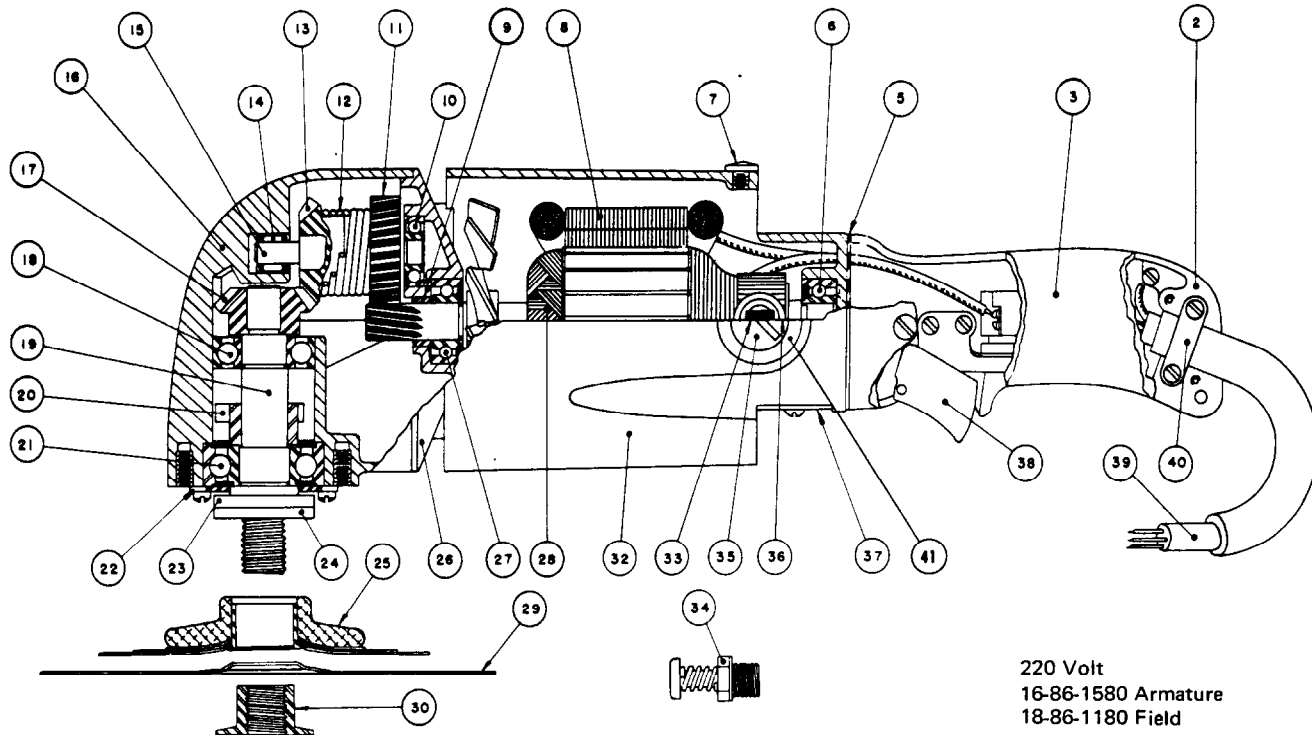

220 Volt  
16-86-1580 Armature  
18-86-1180 Field

ILLUSTRATED PARTS

FIG.	PART NO.	DESCRIPTION OF PART	FIG.	PART NO.	DESCRIPTION OF PART
2	28-44-1041	Handle (Switch Mounting Side)	22	45-88-0220	Ball Bearing Retaining Washer
3	28-44-9081	Handle (Switch Cover Side)	23	45-88-0141	Hub Steel Washer
5	43-86-0050	Handle Insulator	24	45-88-0160	Hub Rubber Washer
6	02-04-1070	Ball Bearing (Commutator End)	25	48-80-0750	5" Flat Disc Hub Assembly
7	06-77-1400	Drive Screw Tool Rest Button	26	28-28-0381	Diaphragm
8	18-82-1180	Field Assembly	27	02-04-1340	Ball Bearing (Pinion End)
9	45-28-0080	Grease Slinger	28	16-82-1710	Armature Assembly
10	02-04-0910	Ball Bearing	29	48-80-0900	7" Flat Backing Disc
11	32-40-1481	Intermediate Gear	30	44-40-0120	Disc Nut (5/8"-11 Thread)
12	40-50-3200	Spindle Drive Spring	*32	26-50-4562	Motor Housing (Includes item no. 41 & screws)
13	32-50-1261	Miter Gear (sold only with 32-50-1241 as a set)	33	22-18-0260	Carbon Brush Assembly
14	02-50-2130	Needle Bearing	34	44-20-0060	Spindle Lock Assembly
15	36-66-3301	Intermediate Shaft	35	23-44-0065	Brush Retaining Cap
16	28-14-0601	Gear Case	36	22-22-0130	Brush Holder Assembly (per set 2)
17	32-50-1241	Refer to item 13	37	44-66-0100	Commutator Cover Plate
18	02-04-1710	Ball Bearing (Upper)	38	23-66-0250	Switch Assembly
19	38-50-1751	Spindle (5/8"-11 Thread)	39	22-64-0090	Cord Set
20	42-74-0061	Spindle Lock Cog	40	28-17-0200	Cord Clamp Strap
21	02-04-2060	Ball Bearing (Lower)	41	22-24-0100	Brush Holder Bushing (steel) (2)

MISCELLANEOUS PARTS NOT SHOWN

PART NO.	DESCRIPTION OF PART	PART NO.	DESCRIPTION OF PART
28-79-0241	Tool Rest	06-81-8650	6-32x1/4" Rd. Hd. Comm. Cover Plate Scs. (Sem) (2)
48-03-0010	Adapter Plug	06-81-3700	8-32x7/8 Oval Hd. Handle Cover Screws (2)
12-98-3500	Name Plate	06-81-6150	8-32x1/2 Fil. Hd. Cord Clamp Strap Screws (Sem) (2)
43-62-0141	Side Handle Assembly	06-81-5400	8-32x5/16 Binder Hd. Switch Mounting Screws (2)
06-81-6950	10-24x1/2 Fil. Hd. Sem Tool Rest Screw (2)	06-81-9225	10-24x2-3/4 Rd. Hd. Field Sems (2)
06-83-2650	1/4-20x3/8 Hd'less Brush Holder Set Screws (2)	06-81-8625	6-32x1/4 Rd. Hd. Ground Wire Sc. (Brass)(Sem)
*06-81-7300	10-24x1-3/4 Fil. Hd. Gear Case Screws (Sem) (4)	06-81-8200	4-36x3/16 Rd. Hd. Name Plate Screws (Sem)
06-81-7550	12-24x3/4 Fil. Hd. Switch Handle Screws (Sem) (4)	*06-42-1600	Woodruff Key
06-81-3750	8-32x1 Oval Hd. Handle Cover Screw (4)	*06-97-1800	Lock Washer (4)
06-81-6050	8-32x5/16 Fil. Hd. Ret. Washer Screws (Sem) (6)	*45-88-5320	Flat Washer
		*23-86-0075	Insulating Washer (2)