



SERVICE PARTS LIST

BULLETIN NO.
54-37-0110

SPECIFY CATALOG NO. AND SERIAL NO. WHEN ORDERING PARTS		REVISED BULLETIN 54-37-0109	DATE April '95
1 H.P. ROUTER			
CATALOG NO.	5620	SERIAL NUMBER	451A
		WIRING INSTRUCTION 58-01-0703	

EXAMPLE:



Component Parts (Small #) Are Included
When Ordering The Assembly (Large #).

FOR SERIAL NUMBERS:
451A194410001 THRU 451A194410005
USE SERVICE PARTS LIST ON
REVERSE SIDE OF THIS BULLETIN

Catalog No. 5620 Includes:

5610 Router Motor Assy. (Figs. 1 thru 33) and

48-10-0070 Router Base Assy. (Figs. 34 thru 45)

FIG.	PART NO.	DESCRIPTION OF PART	NO. REQ.
1	06-82-7261	6-19 x 11/16" Pan Hd. Plastite T-15 Screw	(2)
2	06-82-7290	6-19 x 1-1/8" Pan Hd. Plastite T-15 Screw	(2)
3	31-17-0171	Switch Clamp	(1)
4	42-42-0190	Switch Button	(1)
5	23-44-0140	Brush Cap	(2)
6	22-18-0441	Carbon Brush Assembly	(2)
7	23-66-1220	Toggle Switch	(1)
8	06-82-5531	8-32 x 1-7/8" Pan Hd. Taptite T-20 Screw	(4)
9	12-98-6965	Identification Plate	(1)
10	31-12-0156	Upper Bearing Cap Assembly	(1)
11	06-82-7270	8-16 x 5/8" Pan Hd. Slit. Plast. T-20 Screw	(2)
12	02-04-0850	Ball Bearing	(1)
13	18-50-0030	120 V. Field	(1)
★ 14	06-82-7453	8-16 x 2-1/4" Pan Hd. Plastite T-20 Screw	(2)
15	23-16-0680	Insulating Sleeve	(1)
16	23-50-0070	Insulating Spacer	(1)
17	16-50-0210	120 V. Armature	(1)
18	06-95-3241	8-32 x 1/2" Flat Hd. Screw	(3)
19	44-66-5305	Bearing Retainer	(1)
20	02-04-1610	Ball Bearing	(1)
21	28-50-6171	Motor Housing	(1)
22	06-81-8625	6-32 x 1/4" Ground Screw	(1)
23	31-58-0010	Adjusting Ring	(1)
24	45-10-0070	Chuck Shank	(1)
25	48-66-0980	1/4" Collet	(1)
26	44-40-0465	Collet Nut	(1)
27	06-75-3005	1/4-20 x 5/8" Socket Hd. Screw	(1)
28	06-81-5210	6-32 x 1/4" Washer Hd. Screw	(1)
★ 29	12-20-0590	Service Nameplate Kit	(1)
30	22-64-0121	Cord Set	(1)
31	44-76-0150	Cord Protector	(1)
32	31-17-0156	Cord Clamp	(1)
33	22-84-0670	Fan	(1)
	48-10-0070	Router Base (Includes Fig. Nos. 34 thru 45)	(1)
34	31-44-0275	Handle	(2)
35	06-82-5554	10-24 x 2-3/8" Pan Hd. Slit. Taptite T-25 Screw	(2)
36	06-75-0230	1/4-20 x 1-3/4" Hex Hd. Screw	(1)
37	26-06-0820	Router Base	(1)
38	06-65-0575	3/32 x 5/16" Long Pin	(1)
★ 39	12-25-0010	Router Base Nameplate	(1)
40	31-06-0090	Sub Base	(1)
41	06-81-4649	10-32 x 7/16" Pan Hd. Taptite Sem.	(2)
42	06-97-5600	Lock Washer	(1)
43	45-36-0680	Locking Knob Spacer	(1)
44	43-98-0070	Locking Knob	(1)
45	06-82-7252	8-32 x 3/8" Pan Hd. Taptite T-20 Screw	(4)
46	28-06-0825	Router Base Assembly	(1)

PARTS NOT SHOWN

49-96-4070	7/8" Open End Wrench	(1)
49-96-4075	1" Open End Wrench	(1)

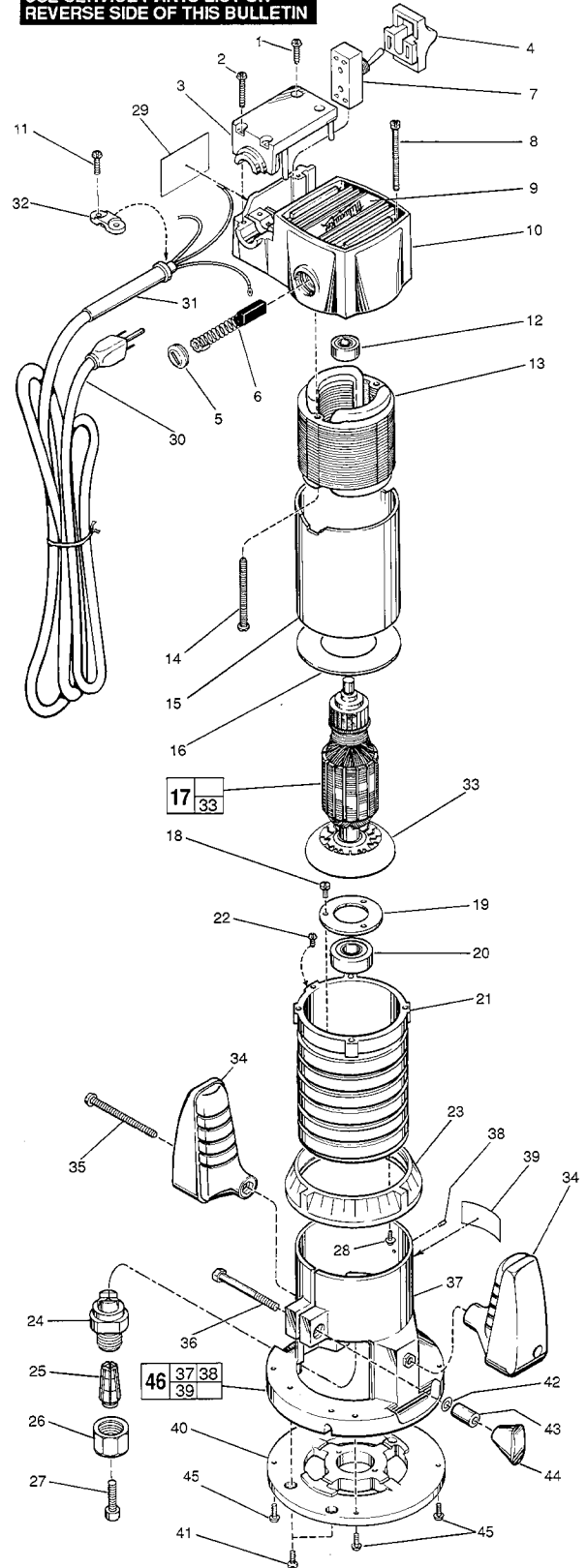



SERVICE PARTS LIST

BULLETIN NO.

SPECIFY CATALOG NO. AND SERIAL NO. WHEN ORDERING PARTS		REVISED BULLETIN	DATE
1 H.P. ROUTER			
CATALOG NO.	5620	WIRING INSTRUCTION	
	SERIAL NUMBER		

EXAMPLE:



Component Parts (Small #) Are Included
When Ordering The Assembly (Large #).

Catalog No. 5620 Includes:

- 5610 Router Motor Assy. (Figs. 1 thru 33) and
- 48-10-0070 Router Base Assy. (Figs. 34 thru 45)

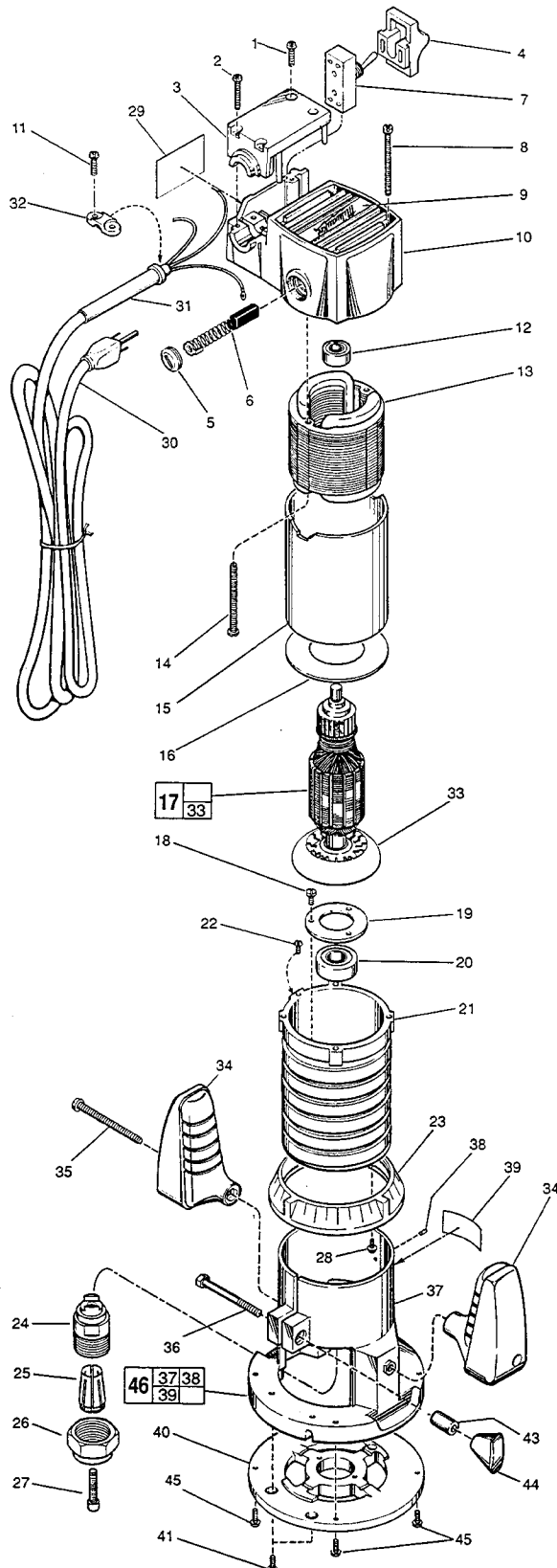

FIG.	PART NO.	DESCRIPTION OF PART	NO. REQ.
1	06-82-7261	6-19 x 11/16" Pan Hd. Plastite T-15 Screw	(2)
2	06-82-7290	6-19 x 1-1/8" Pan Hd. Plastite T-15 Screw	(2)
3	31-17-0171	Switch Clamp	(1)
4	42-42-0190	Switch Button	(1)
5	23-44-0140	Brush Cap	(2)
6	22-18-0441	Carbon Brush Assembly	(2)
7	23-66-1220	Toggle Switch	(1)
8	06-82-5531	8-32 x 1-7/8" Pan Hd. Taptite T-20 Screw	(4)
9	12-98-6965	Identification Plate	(1)
10	31-12-0156	Upper Bearing Cap Assembly	(1)
11	06-82-7270	8-16 x 5/8" Pan Hd. Slit. Plast. T-20 Screw	(2)
12	02-04-0850	Ball Bearing	(1)
13	18-50-0030	120 V. Field	(1)
14	06-82-7453	8-16 x 2-1/4" Pan Hd. Plastite T-20 Screw	(2)
15	23-16-0680	Insulating Sleeve	(1)
16	23-50-0070	Insulating Spacer	(1)
★ 17	16-50-0215	120 V. Armature	(1)
★ 18	06-82-3792	8-32 x 3/8" Flat Hd. Taptite T-15 Screw	(3)
★ 19	44-66-6050	Bearing Retainer	(1)
20	02-04-1610	Ball Bearing	(1)
21	28-50-6171	Motor Housing	(1)
22	06-81-8625	6-32 x 1/4" Ground Screw	(1)
23	31-58-0010	Adjusting Ring	(1)
★ 24	45-10-0076	Chuck Shank	(1)
★ 25	48-66-0985	1/4" Collet	(1)
★ 26	44-40-0471	Collet Nut	(1)
27	06-75-3005	1/4-20 x 5/8" Socket Hd. Screw	(1)
28	06-81-5210	6-32 x 1/4" Washer Hd. Screw	(1)
29	12-20-0590	Service Nameplate Kit	(1)
30	22-64-0121	Cord Set	(1)
31	44-76-0150	Cord Protector	(1)
32	31-17-0156	Cord Clamp	(1)
33	22-84-0670	Fan	(1)
48-10-0070	Router Base (Includes Fig. Nos. 34 thru 45)	(1)	
34	31-44-0275	Handle	(2)
35	06-82-5554	10-24 x 2-3/8" Pan Hd. Slit. Taptite T-25 Screw	(2)
36	06-75-0230	1/4-20 x 1-3/4" Hex Hd. Screw	(1)
37	26-06-0820	Router Base	(1)
38	06-65-0575	3/32 x 5/16" Long Pin	(1)
39	12-25-0010	Router Base Nameplate	(1)
40	31-06-0090	Sub Base	(1)
★ 41	06-82-8865	10-32 x 7/16" Pan Hd. Taptite Sem. T-25	(2)
★ 43	45-36-1560	Locking Knob Spacer	(1)
★ 44	43-98-0510	Locking Knob	(1)
45	06-82-7252	8-32 x 3/8" Pan Hd. Taptite T-20 Screw	(4)
46	28-06-0825	Router Base Assembly	(1)

PARTS NOT SHOWN

★	49-96-4070	7/8" Open End Wrench	(1)
★	49-96-4100	1-1/4" Open End Wrench	(1)