



SERVICE PARTS LIST

BUL. 54-32-1214

9" POLISHER

REVISED BUL. 647-5 DATE Feb. '68

Catalog No. 5590

Starting Serial No. **47-4691**

WIRING INSTR.

Both Model and Serial No. must be furnished to obtain correct parts.

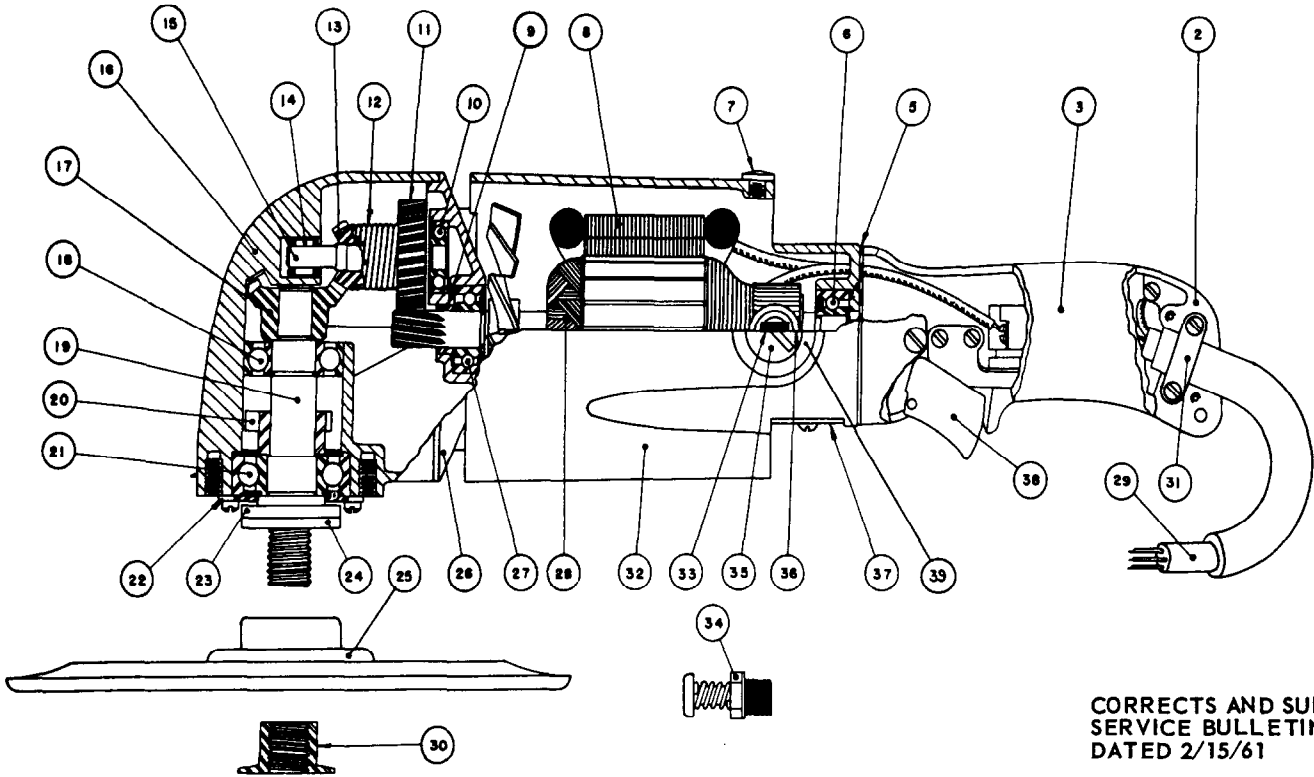

CORRECTS AND SUPERCEDES SERVICE BULLETIN 647-5 DATED 2/15/61

FIG.	PART NO.	DESCRIPTION OF PART
2	28-44-1041	Handle (Switch Mounting Side)
3	28-44-9081	Handle (Switch Cover Side)
5	43-86-0050	Handle Insulator
6	02-04-1070	Ball Brg. (Comm. End)
7	06-77-1400	Drive Screw Tool Rest Button
★ 8	18-82-1110	Field Assembly
9	45-28-0050	Grease Slinger
★ 10	02-04-0910	Ball Bearing
11	32-40-1181	Intermediate Gear
12	40-50-3100	Spindle Drive Spring
13	32-05-1022	Bevel Gear (Sold only with 32-05-1001 as set)
14	02-50-2130	Needle Bearing
15	36-66-1701	Intermediate Shaft
16	28-14-0601	Gear Case
17	32-05-1001	See Item 13
18	02-04-1710	Ball Bearing (Upper)
19	38-50-1751	Spindle (5/8-11 thread)
20	42-74-0061	Spindle Lock Cog
21	02-04-2060	Ball Bearing (Lower)

ILLUSTRATED PARTS

FIG.	PART NO.	DESCRIPTION OF PART
22	45-88-0220	Ball Brg. Retaining Washer
23	45-88-0141	Hub Steel Washer
24	45-88-0160	Hub Rubber Washer
25	49-36-2200	9" Polisher Pad
26	28-28-0381	Diaphragm
27	02-04-1140	Ball Brg. (Pinion End)
28	16-82-1180	Armature Assembly
29	22-64-0090	Cord Set
30	44-40-0160	Disc Nut (5/8"-11 thr'd)
31	28-17-0200	Cord Clamp Strap
32	27-50-4562	Motor Housing (Includes item no. 39 & screws)
★ 33	22-18-0260	Carbon Brush Assemblies (per set 2)
34	44-20-0060	Spindle Lock Assembly
35	23-44-0065	Brush Retaining Cap (per set 2)
★ 36	22-22-0130	Brush Holder Assembly
37	44-66-0100	Commutator Cover Plate
38	23-66-0250	Switch Assembly
39	22-24-0100	Brush Holder Bushing (steel)

MISCELLANEOUS PARTS NOT SHOWN

PART NO.	DESCRIPTION OF PART	PART NO.	DESCRIPTION OF PART
28-79-0241	Tool Rest	06-81-8650	6-32x1/4" Rd. Hd. Comm. Cover Plate Scs. (Sem) (2)
48-03-0010	Adapter Plug	06-81-3700	8-32x7/8" Oval Hd. Handle Cover Screws (2)
12-98-2500	Name Plate	06-81-6100	8-32x7/16" Fil. Hd. Cord Clamp Strap Scs. (Sem) (2)
43-62-0141	Side Handle	06-81-5400	8-32x5/16" Binder Switch Mounting Screws (2)
06-81-6950	10-24x1/2" Fil. Hd. Sem. Tool Rest Scs. (2)	06-81-9200	10-24x2-1/2" Rd. Hd. Field Sems (2)
06-83-2650	1/4"-20x3/8" Hd'less Brush Holder Set Sc. (2)	06-81-8625	6-32x1/4" Rd. Hd. Ground Wire Sc. (Brass) (Sem)
06-81-7550	12-24x3/4" Fil. Hd. Switch Handle Scs. (Sem) (4)	06-81-8200	4-36x3/16" Rd. Hd. Name Plate Scs. (Sem) (2)
06-81-7250	10-24x1-1/2" Fil. Hd. Gear Case Scs. (Sem) (4)	06-81-6050	8-32x5/16" Fil. Hd. Ret. Washer Scs. (Sem) (6)
06-81-3750	8-32x1" Oval Hd. Handle Cover Screw	23-86-0130	Insulating Washer (2)

Numbers in brackets indicate number required.