

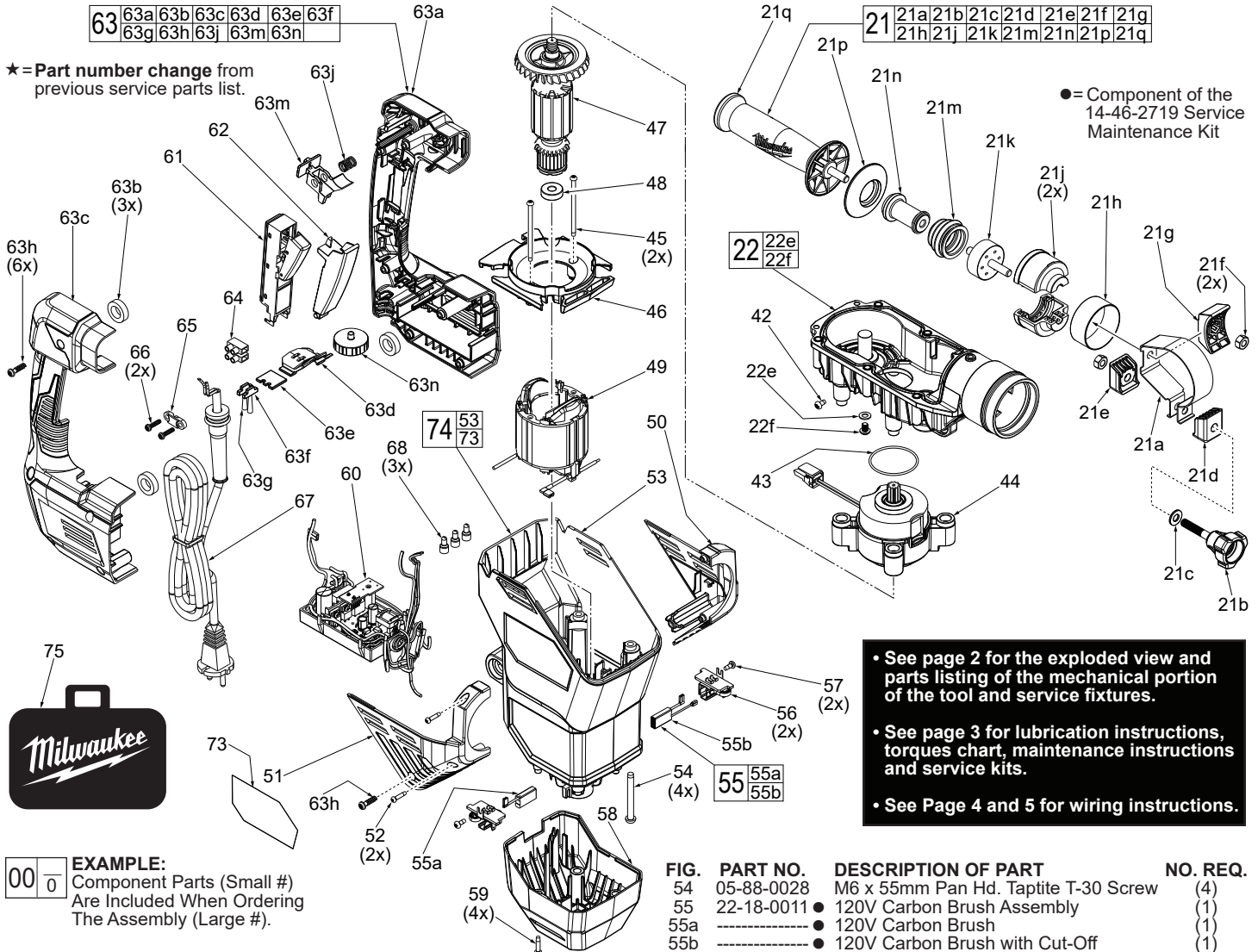

SERVICE PARTS LIST

BULLETIN NO.
54-24-2791

SPECIFY CATALOG NO. AND SERIAL NO. WHEN ORDERING PARTS		REVISED BULLETIN 54-24-2790	DATE Apr. 2022
1-3/4" SDS-Max Rotary Hammer			
CATALOG NO.	5546-21	STARTING SERIAL	K61B
		WIRING INSTRUCTION SEE PAGES 4 & 5	



★ = Part number change from previous service parts list.

● = Component of the 14-46-2719 Service Maintenance Kit

- See page 2 for the exploded view and parts listing of the mechanical portion of the tool and service fixtures.
- See page 3 for lubrication instructions, torques chart, maintenance instructions and service kits.
- See Page 4 and 5 for wiring instructions.

EXAMPLE:
Component Parts (Small #) Are Included When Ordering The Assembly (Large #).

FIG.	PART NO.	DESCRIPTION OF PART	NO. REQ.
21	42-62-0013	Side Handle Assembly	(1)
21a	31-05-0011	Clamping Ring	(1)
21b	05-89-0015	Fixing Screw	(1)
21c	45-88-0103	Flat Washer	(1)
21d	43-72-0002	Holder 1	(1)
21e	43-72-0003	Holder 2	(1)
21f	05-55-0018	Hex Nut	(2)
21g	44-66-0049	Support Plate	(1)
21h	44-90-0046	Ring	(1)
21j	43-76-0012	Absorber Housing	(2)
21k	44-52-0013	Absorber	(1)
21m	43-87-0015	Bellows	(1)
21n	43-24-0010	Extension	(1)
21p	42-52-0031	Side Handle Cap	(1)
21q	43-98-5316	Side Handle	(1)
★ 22	14-29-0014	Gearcase Assembly	(1)
22e	-----	Flat Washer	(1)
22f	-----	M6 x 10mm Pan Hd. Hex Drive Mach. Scr.	(1)
42	06-82-8828	8-32UNC x .313" Pan Hd. Taptite T-20 Scr.	(1)
43	34-40-0088	● O-Ring	(1)
44	42-70-0128	EM-Clutch Assembly	(1)
45	05-88-1275	M4 x 70mm Pan Hd. ST Phillips Screw	(2)
46	42-14-0027	Fan Baffle	(1)
47	16-01-0011	Armature Assembly	(1)
48	02-04-0530	Ball Bearing	(1)
49	18-01-0011	Field Assembly	(1)
50	43-76-0013	Front Housing Support - Left	(1)
51	43-76-0014	Front Housing Cover - Right	(1)
52	06-82-2025	M3.5 x 16mm Pan Hd. Plastite T-10 Screw	(2)
53	-----	Motor Housing	(1)

FIG.	PART NO.	DESCRIPTION OF PART	NO. REQ.
54	05-88-0028	M6 x 55mm Pan Hd. Taptite T-30 Screw	(4)
55	22-18-0011	● 120V Carbon Brush Assembly	(1)
55a	-----	● 120V Carbon Brush	(1)
55b	-----	● 120V Carbon Brush with Cut-Off	(1)
56	22-22-0021	Brush Holder Assembly	(2)
57	05-78-5313	M4 x 9mm Pan Hd. Plastite T-15 Screw	(2)
58	42-92-0049	Bottom Cover	(1)
59	06-82-0121	M4 x 18mm Pan Hd. ST T-20 Screw	(4)
60	14-20-0090	120V PCBA	(1)
61	23-66-0059	120V On-Off Switch	(1)
62	45-72-0017	Switch Trigger	(1)
63	14-34-0012	Handle Service Kit	(1)
63a	-----	Handle Support - Left	(1)
63b	42-42-0054	● Foam Bushing	(3)
63c	-----	Handle Cover - Right	(1)
63d	44-66-0098	Auto Stop Plate	(1)
63e	44-66-0099	LED Lens Holder Plate	(1)
63f	44-06-0007	Working Lens with Ink Print	(1)
63g	44-06-0008	Working Lens	(1)
63h	05-78-5311	M5 x 18mm Pan Hd. ST T-20 Screw	(7)
63j	40-50-0059	Spring	(1)
63m	44-60-0074	Lock Button	(1)
63n	43-98-0029	Speed Dial	(1)
64	22-56-0475	Terminal Block	(1)
65	31-17-0155	Cord Clamp	(1)
66	06-82-0995	M4 x 16mm Pan Hd. Plastite T-20 Screw	(2)
67	22-64-0019	120V Power Cord with Strain Relief	(1)
68	22-56-0150	Closed End Connector	(3)
73	12-20-0161	Service Nameplate	(1)
74	14-38-0032	Motor Housing Kit	(1)
75	42-55-0073	Blow Molded Carrying Case	(1)
	23-94-0048	Ground Wire Assembly (Not Shown)	(1)

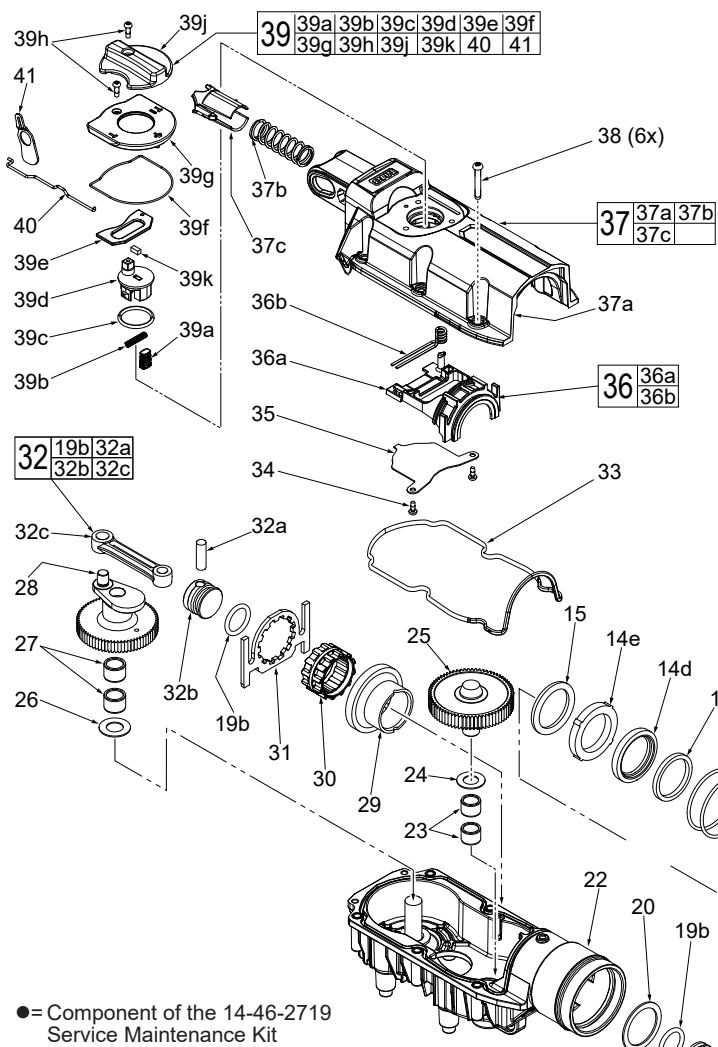
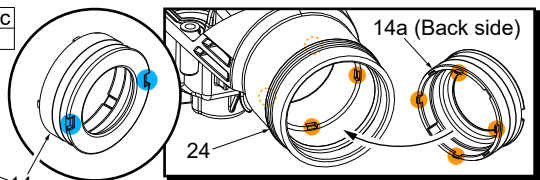

FIG.	PART NO.	DESCRIPTION OF PART	NO. REQ.
23	02-50-0018	Needle Bearing	(2)
24	45-88-0074	Washer	(1)
25	32-10-0012	Clutch Assembly	(1)
26	45-88-5327	Washer	(1)
27	02-50-5315	Needle Bearing	(2)
28	32-62-0010	Crank Shaft	(1)
29	32-05-0016	Spindle Bevel Gear	(1)
30	42-76-0014	Drive Sleeve	(1)
31	44-66-0048	Locking Plate	(1)
32	14-09-0015	Piston and Connecting Rod Assembly	(1)
32a	-----	Wrist Pin	(1)
32b	-----	Piston	(1)
32c	44-94-0016	Connecting Rod	(1)
33	43-44-0012	Rubber Gasket	(1)
34	05-78-5313	M4 x 14mm Pan Hd. Taptite T-20	(2)
35	42-36-0024	Selector Bracket Clamp Plate	(1)
36	14-46-0100	Fork Assembly	(1)
36a	-----	Fork	(1)
36b	-----	Fork Assembly Spring	(1)
37	31-15-0137	Gearcase Cover Kit	(1)
37a	31-15-0128	Gearcase Cover	(1)
37b	40-50-0149	Spring	(1)
37c	43-56-0011	Spring Carrier	(1)
38	05-78-5315	M5 x 33mm Pan Hd. Taptite T-25 Screw	(6)
39	23-66-0271	Selector Knob Assembly	(1)
39a	31-53-0010	Rubber Plug	(1)

● = Component of the 14-46-2719 Service Maintenance Kit

FIG.	PART NO.	DESCRIPTION OF PART	NO. REQ.
1	45-12-5316	Rubber Dust Shield	(1)
2	45-22-5317	Front Latch Sleeve	(1)
3	34-60-5316	Retaining Ring	(1)
4	45-88-5316	Washer	(1)
5	34-40-5316	Spindle O-Ring	(2)
6	45-88-5321	Washer	(1)
7	45-22-5319	Sliding Collar	(1)
8	45-22-5321	Locking Sleeve	(1)
9	45-88-5371	Washer	(1)
10	44-66-0034	Front Spring Retainer	(1)
11	40-50-5318	Spring	(1)
12	44-66-5314	Rear Spring Retainer	(1)
13	34-40-5315	Retaining Ring	(1)
14	14-46-5316	Bearing Shield Assembly	(1)
14a	-----	Bearing Shield	(1)
14b	34-40-5321	O-Ring	(2)
14c	45-06-5170	Felt Seal	(1)
14d	45-06-5180	Rotary Seal	(1)
14e	02-50-5316	Bearing Ring	(1)
15	45-88-0076	O-Ring	(1)
16	44-20-5316	Key	(2)
17	38-50-0012	SDS-Max Spindle Assembly	(1)
17a	44-82-5317	SDS-Max Spindle	(1)
17b	44-90-0037	Brake Ring	(1)
17c	44-90-0039	Rebound Ring	(1)
17d	34-60-0072	Back Press Ring	(1)
17e	44-60-5316	Spindle Sleeve Pin	(6)
17f	44-90-5317	Steel Ring	(1)
17g	44-90-5319	Spring Ring	(1)
17h	45-22-0013	Barrel	(1)
18	42-06-0028	Anvil Assembly	(1)
18a	-----	Anvil	(1)
18b	34-60-5319	O-Ring	(2)
18c	45-06-5317	Turcon Seal	(2)
19	45-56-0018	Striker Assembly	(1)
19a	45-22-0016	Striker	(1)
19b	34-40-0078	O-Ring	(2)
20	45-88-0073	Washer	(1)
★22	14-29-0014	Gearcase Assembly	(1)



Be sure to orient front notches of bearing shield #14a at the 12:00/6:00 position or at the 9:00/3:00 position prior to installing in gearcase #22. Doing so will allow tabs in rear of bearing shield to seat in corresponding notches in gear case cavity. This must be done to allow for proper seating of retaining ring #13.

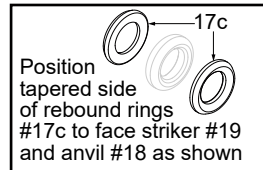
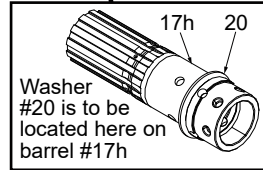
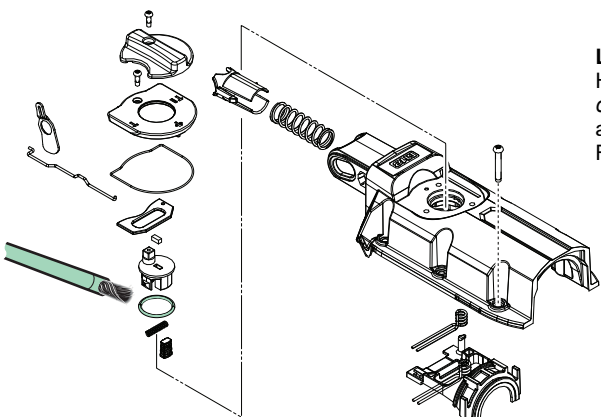
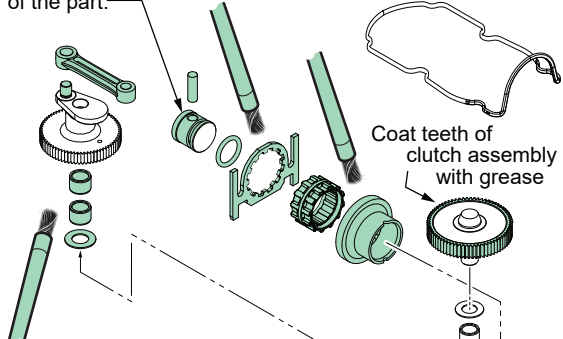

FIG.	PART NO.	DESCRIPTION OF PART	NO. REQ.
39b	40-50-5320	Spring	(1)
39c	34-40-5309	O-Ring	(1)
39d	44-60-0067	Selector Knob with Knob Pin Insert	(1)
39e	44-20-0018	Chisel Lock Arm	(1)
39f	43-44-0014	Selector Knob Gasket	(1)
39g	43-56-0112	Selector Guide	(1)
39h	06-82-0032	M4 x 12mm Pan Hd. ST T-20 Screw	(2)
39j	43-98-0014	Selector Knob	(1)
39k	31-53-0011	Felt Plug	(1)
40	44-94-0014	Lock Rod	(1)
41	42-50-0013	Lock Cam	(1)
	50-08-5317	Bit Grease	(1)

Lubrication Note: MILWAUKEE recommends that scheduled maintenance of this Rotary Hammer include lubrication replacement, and replacement of vital O-rings and gaskets *at each carbon brush change*. Doing so will prolong the life of the hammer by reducing wear to gears and mechanism parts. The carbon brushes and armature commutator in this MILWAUKEE Rotary Hammer are designed and matched for many hours of reliable performance.



Pack the rear of the piston with grease. There is to be no lubrication on the face of the part.



Coat teeth of clutch assembly with grease

Place 6-5/16 oz. (180g) of grease in the bottom of the gearcase

Place 5/8 oz. (18g) of grease in the rear of the barrel before installing the striker

1. Place washer #20 onto backside of barrel.
2. Place 18 grams of 'Q2' grease inside barrel.
3. Coat o-ring groove on ram and o-ring with grease prior to installing o-ring on ram.

Coat the assembled ram and o-ring with grease as shown below.
4. When placing ram assembly into barrel, **slowly** apply pressure to ram assembly.
5. Push the ram assembly until rear face is just below small hole in the barrel. **DO NOT** wipe off any excess grease that oozes out of holes.

Fig. 1

LUBRICATION NOTES:
Type 'Q2' Grease, No. 49-08-5355 (2.8oz, 80g tube) 3 tubes needed
 Prior to reinstalling, clean gear assemblies with a clean, dry cloth. Lightly coat all individual parts highlighted here with grease. Apply a greater amount of grease to all internal and external gear teeth. Place 18 grams of grease in the rear of the barrel prior to inserting the ram. Place the remaining grease in the bottom of the gearcase.

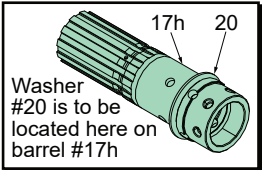

Washer #20 is to be located here on barrel #17h

Coat o-ring and o-ring groove prior to installing o-ring.
 With o-ring installed, coat around entire side of ram

Coat the inside of the spindle driver prior to assembly

NOTE:
 Be sure that the shank of the bit is clean. For best performance, be sure the shank is lightly greased prior to installation. Use Bit Grease No. 50-08-5317.

● 14-46-2719 MAINTENANCE SERVICE KIT

THIS KIT CONTAINS:

1	45-12-5316	Rubber Dust Shield
1	34-60-5316	Retaining Ring
2	34-40-5316	Spindle O-Ring
2	34-60-5319	O-Ring
2	45-06-5317	Turcon Seal
2	34-40-5308	O-Ring
2	42-42-0054	Foam Bushing
1	14-46-5316	Bearing Shield Assembly
1	34-60-0072	Back Press Ring
2	34-60-0078	O-Ring
1	43-44-0012	Rubber Gasket
1	34-40-5309	O-Ring
1	44-90-5319	Spring Ring
3	49-08-5355	'Q2' Grease (2.8oz/80g tube)
1	22-18-0011	120V Carbon Brush Assembly

FASTENER TORQUE SPECIFICATIONS (IN./LBS.)

FIG. NO.	WHERE USED	SEATING TORQUE		
		in/lbs	kgf/cm	Nm
34	Selector Bracket Clamp Plate	11	13	1.3
38	Gearcase Cover	44±3	51±4	5.0
47	Motor Housing	56	65	6.4
48d	Housing Halve Cover	25	29	2.9
48c	Housing Halve Cover	11	13	1.3
50b	Coin Cell Cover	2.6	3.05	0.3
39h	Selector Knob	16	18	1.8
39h	On-Off Switch	11	13	1.3
	Switch Termination Screws	8	10	1.0
	Ground Screw-Gearcase	44	50	5.0

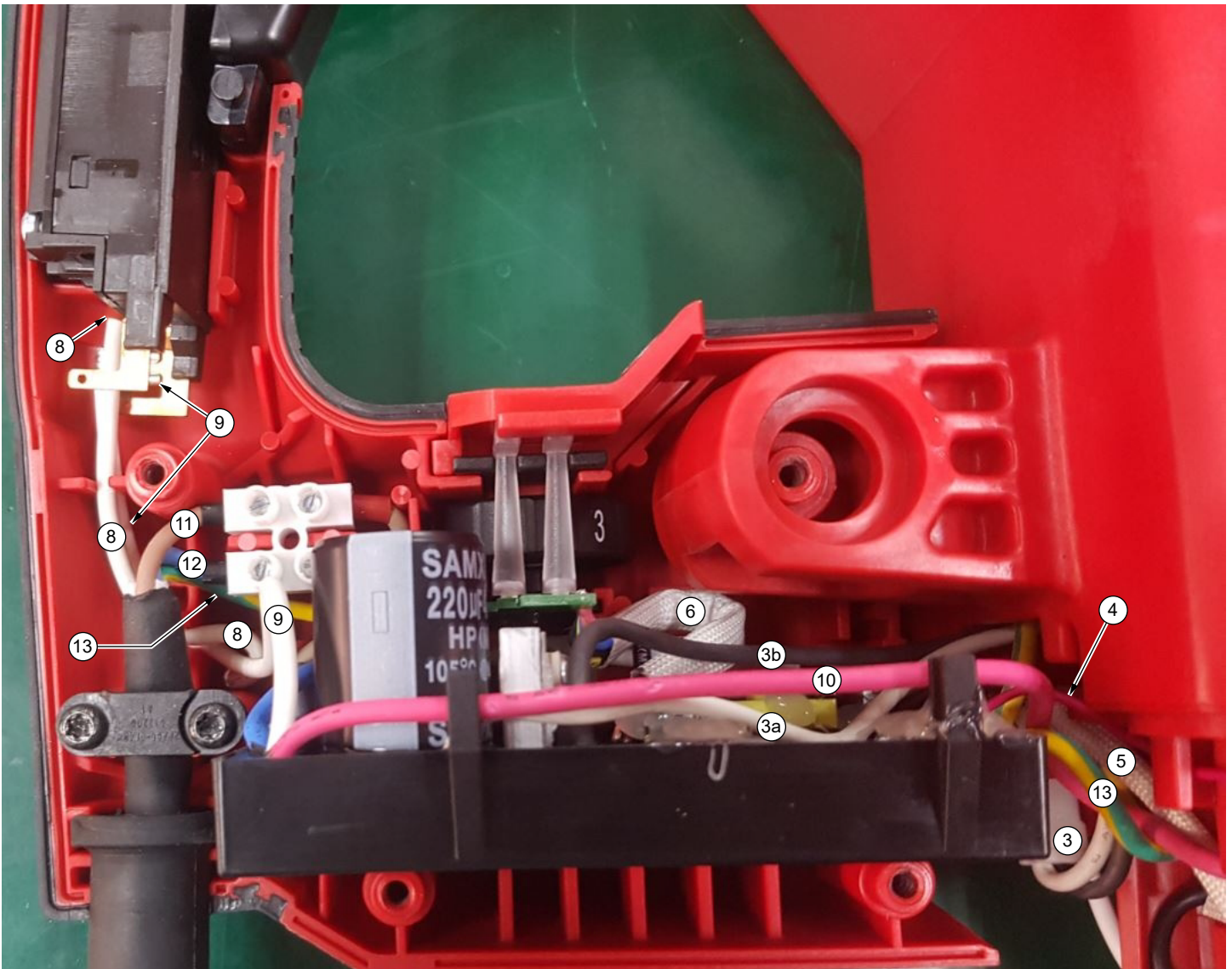

① BROWN From Control Board to top of connector block, opposite to power cord wire #11 (brown or white).

② BLUE From Control Board to bottom of connector block, opposite to power cord wire #12 (blue or black).

③ BLK & WHITE From Control Board. Both black and white wires are terminated together. Connect with black & white wires from EM clutch.

④ RED From Control Board, connect with red wire #19 from right brush.

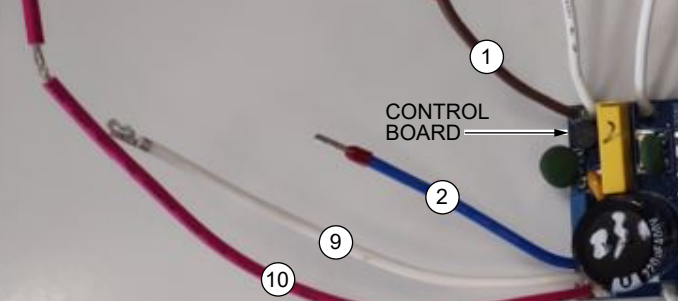

⑤ WHITE, BLUE, BLACK From Control Board to Hall Sensor Board.

⑥ YEL, RD, From Control Board to 'U' Board. BLUE, BLACK, ORANGE

⑦ WHITE From Control Board, connect to white field wire #14 using closed end connector.

⑧ WHITE From Control Board, connect to on-off switch at position 1.

⑨ WHITE From Control Board, connect to on-off switch at position 1 ↑.

⑩ RED From Control Board, connect to red field wire #16 using closed end connector.

⑪ BROWN From Power Cord to connector block opposite wire #1.

⑫ BLUE From Power Cord to connector block opposite wire #2.

⑬ GRN/Y From Power Cord to connect to green/yellow wire #17.

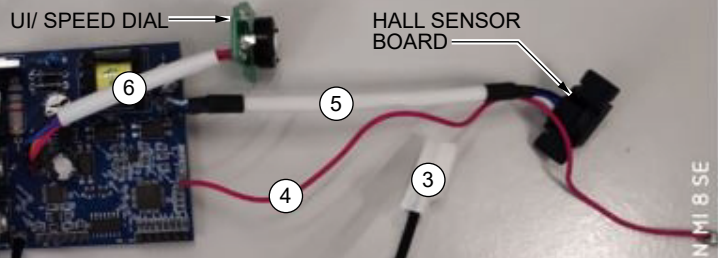

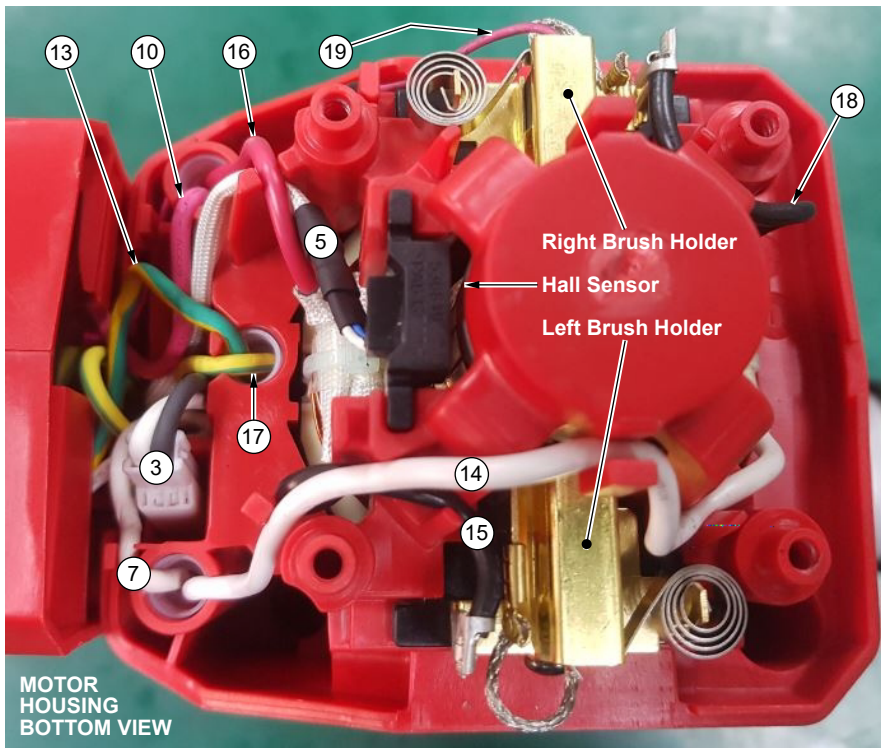

- ③ BLK & WHITE From Control Board. Both black and white wires are terminated together. Connect with black & white wires from EM clutch.
- ⑤ WHITE, BLUE, BLACK From Control Board to Hall Sensor Board.
- ⑦ WHITE From Control Board, connect to white field wire #14 using closed end connector.
- ⑩ RED From Control Board, connect to red field wire #16 using closed end connector.
- ⑬ GRN/Y From Power Cord to connect to green/yellow wire #17 using closed end connector.
- ⑭ WHITE From Field, connect to white wire #7 from control board assembly using closed end connector.
- ⑮ BLACK From Field, connect to left brush holder assembly.
- ⑯ RED From Field, connect with red wire #11 using closed end connector.
- ⑰ GRN/Y Ground wire assembly, connect to green/yellow wire #13 using closed end connector.
- ⑱ BLACK From Field, connect to right brush holder assembly.
- ⑲ RED From Right Brush, connect to red wire #4 from control board.

MOTOR HOUSING BOTTOM VIEW

