

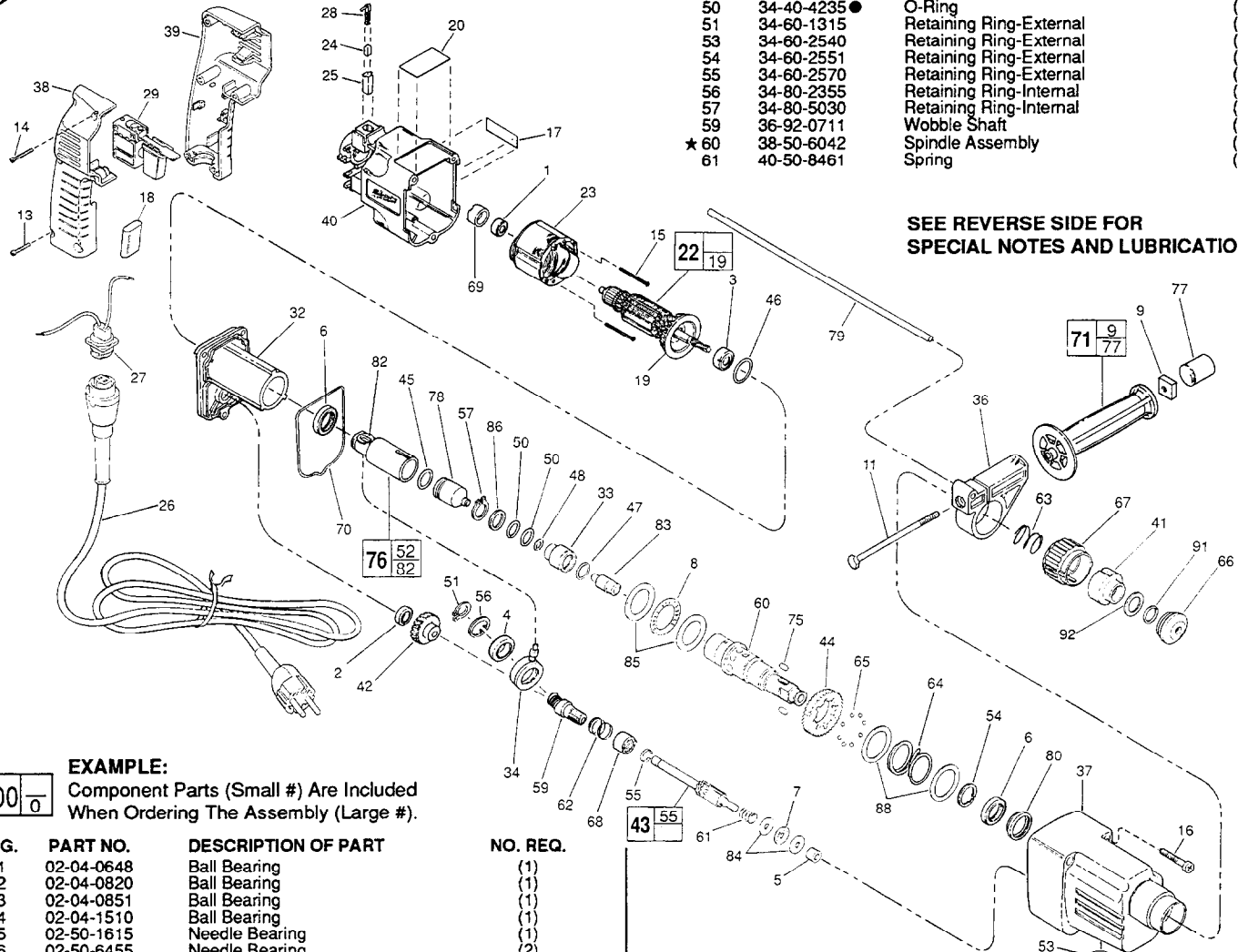

# SERVICE PARTS LIST

**BULLETIN NO.**  
55-24-1369

SPECIFY CATALOG NO. AND SERIAL NO. WHEN ORDERING PARTS		REVISED BULLETIN 55-24-1368	DATE Jan. '97
<b>3/4" ROTARY HAMMER</b>			
CATALOG NO.	5366-51	SERIAL NUMBER	794E
		WIRING INSTRUCTION <b>58-03-1775</b>	



SEE REVERSE SIDE FOR  
SPECIAL NOTES AND LUBRICATION

**EXAMPLE:**  
Component Parts (Small #) Are Included  
When Ordering The Assembly (Large #).



FIG.	PART NO.	DESCRIPTION OF PART	NO. REQ.
1	02-04-0648	Ball Bearing	(1)
2	02-04-0820	Ball Bearing	(1)
3	02-04-0851	Ball Bearing	(1)
4	02-04-1510	Ball Bearing	(1)
5	02-50-1615	Needle Bearing	(1)
6	02-50-6455	Needle Bearing	(2)
7	02-80-0110	Thrust Bearing	(1)
8	02-80-0121	Thrust Bearing	(1)
9	06-54-0300	5/16-18 Square Nut	(1)
10	06-65-3690	1/8 x 1/2 Groove Pin	(1)
11	06-75-5835	5/16-18 x 4-1/2" Hex Hd. Bolt	(1)
13	06-82-7284	8-16 x 3/4" Pan Hd. Slot. Plast. T-20	(4)
14	06-82-7326	8-16 x 1" Pan Hd. Slot. Plast. T-20	(2)
15	06-82-7393	7-18 x 2" Pan Hd. Slot. Plast. T-20	(2)
16	05-88-5988	(K50 x 35mm) Pan Hd. Slot. T-20	(3)
17	10-20-1200	Product Label - Falcon	(1)
18	22-33-0450	Suppressor	(1)
19	22-84-0650	Fan Assembly	(1)
20	12-20-3280	Service Nameplate Kit	(1)
22	16-14-0100	230 V Armature	(1)
23	18-12-0155	230 V Field	(1)
24	22-18-0820 ●	Brush Service Kit	(1)
25	22-20-0810	Brush Tube	(2)
26	48-76-5012	Quik-Lok Cord Set	(1)
27	22-56-0694	Blade Housing Assembly	(1)
28	22-18-0850 ●	Brush Spring Assembly	(2)
29	23-66-2125	Switch	(1)
32	28-28-2030	Diaphragm	(1)
33	30-37-0050	Striker Guide	(1)
34	30-72-0100	Wobble Plate	(1)
36	31-17-0230	Handle Ring	(1)
37	31-40-0075	Gear Case	(1)
★ 38	31-44-1781	Right Handle Half	(1)
★ 39	31-44-1785	Left Handle Half	(1)
★ 40	31-50-0991	Motor Housing	(1)
★ 41	31-58-0522	Chuck Sleeve	(1)
42	32-40-2230	Intermediate Gear	(1)
43	14-29-0051	Pinion Shaft Assembly	(1)
44	32-10-4080	Clutch Gear	(1)
45	34-40-1215 ●	O-Ring	(1)
46	34-40-2450 ●	O-Ring	(1)
47	34-40-4220 ●	O-Ring	(1)
48	34-40-4225 ●	O-Ring	(2)
50	34-40-4235 ●	O-Ring	(1)
51	34-60-1315	Retaining Ring-External	(1)
53	34-60-2540	Retaining Ring-External	(1)
54	34-60-2551	Retaining Ring-External	(1)
55	34-60-2570	Retaining Ring-External	(1)
56	34-80-2355	Retaining Ring-Internal	(1)
57	34-80-5030	Retaining Ring-Internal	(1)
59	36-92-0711	Wobble Shaft	(1)
★ 60	38-50-6042	Spindle Assembly	(1)
61	40-50-8461	Spring	(1)
62	40-50-8470	Spring	(1)
63	40-50-8481	Spring	(1)
64	40-50-8491	Spring	(1)
65	02-02-1300	Ball	(8)
★ 66	42-76-0672 ●	Dust Cap	(1)
67	42-76-0291	Chuck Collar	(1)
68	42-90-0261	Coupling	(1)
69	42-96-0140	Bearing Cup	(1)
70	43-44-0930 ●	Gasket	(1)
71	43-62-0841	Side Handle Assembly	(1)
72	14-49-0010 ●	Shift Knob Assembly	(1)
75	44-60-1150	Roller Pin	(2)
76	14-09-0130 ●	Piston Assembly	(1)
77	44-68-0560	Plug - Cap	(1)
78	44-82-0140	Ram	(1)
79	44-94-0161	Depth Rod	(1)
80	45-06-0560	Oil Seal	(1)
82	45-34-0121	Socket	(1)
83	45-56-2591	Striker	(1)
84	45-88-8280	Thrust Washer	(2)
85	45-88-8291	Thrust Washer	(2)
86	45-88-8300	Washer	(1)
87	45-88-8310	Washer	(1)
88	45-88-8321	Washer	(2)
89	45-88-8330	Tab Washer	(1)
★ 91	34-60-3680 ●	Retaining Ring	(1)
★ 92	45-88-8835	Washer	(1)
	14-46-5368	Lubrication Service Kit	(1)

**MILWAUKEE ELECTRIC TOOL CORPORATION**  
13135 W. LISBON RD., BROOKFIELD, WI 53005

**SERVICE FIXTURES:**

- 61-30-0280 Pressing Tool
- 61-30-0290 Assembly Tool

**LUBRICATION INSTRUCTIONS**

Type "N" Grease, No. 49-08-4230

Apply a thin film of grease to the following parts as indicated:

- FIG. INSTRUCTION**
- 60 Large I.D. of spindle, forward and rear bearing journals.
  - 33 Large I.D. of striker guide.
  - 83 Striker-all over.
  - 76,82 Inside and outside diameters of piston assembly, including I.D. of socket.
  - 78 All over ram, except rear face.
  - 59 Outside bearing journal of wobble shaft.
  - 34 Bearing bore and ball diameter of wobble plate.
  - 32 Armature and intermediate bearing bores of diaphragm.
  - 9 Square nut threads.
  - 45,46,50 O-rings.

Apply a thin to moderately heavy coat of grease to the following parts indicated:

- FIG. INSTRUCTION**
- 58 Apply over the length shown in the "Intermediate Shaft Assembly".
  - 75 Roller Pins (This also to aid in assembly).
  - 47,48 O-rings.
  - 42,43,44 All gear and pinion teeth.

**CAUTION: THERE IS TO BE NO GREASE IN THE CHAMBER BETWEEN THE PISTON AND RAM BEYOND THE THIN COATINGS APPLIED TO THE TWO PARTS AS DESCRIBED ABOVE.**

▲ **SEE ASSEMBLY LUBRICATION NOTE**

**•14-46-5368 LUBRICATION SERVICE KIT**  
THIS KIT INCLUDES:

- |   |            |                  |
|---|------------|------------------|
| 1 | 34-40-1215 | O-Ring           |
| 1 | 34-40-4220 | O-Ring           |
| 1 | 34-40-4225 | O-Ring           |
| 2 | 34-40-4235 | O-Ring           |
| 1 | 34-40-2450 | O-Ring           |
| 1 | 34-60-3610 | Retaining Ring   |
| 1 | 34-60-3680 | Retaining Ring   |
| 1 | 34-80-5030 | Retaining Ring   |
| 1 | 42-76-0670 | Dust Cap         |
| 1 | 42-76-0672 | Dust Cap         |
| 1 | 43-44-0930 | Gasket           |
| 2 | 44-60-1150 | Roller Pin       |
| 1 | 49-08-4230 | 5 Oz. "N" Grease |

**22-18-0820 BRUSH SERVICE KIT**  
THIS KIT INCLUDES:

- |   |            |                    |
|---|------------|--------------------|
| 2 | 22-18-0850 | Brush Spring Assy. |
| 2 | 44-52-0495 | Foam Slug          |

**Lubrication Note:** MILWAUKEE recommends that scheduled maintenance of the Falcon Rotary Hammer include lubrication replacement, and replacement of vital O-rings and gaskets at each carbon brush change. Doing so will prolong the life of the hammer by reducing wear to gears and mechanism parts. The carbon brushes and armature commutator in the MILWAUKEE Falcon Rotary Hammer are designed and matched for many hours of reliable performance. The carbon brushes feature a unique pop-out feature which automatically shuts off the tool when the brushes are worn and need to be replaced.

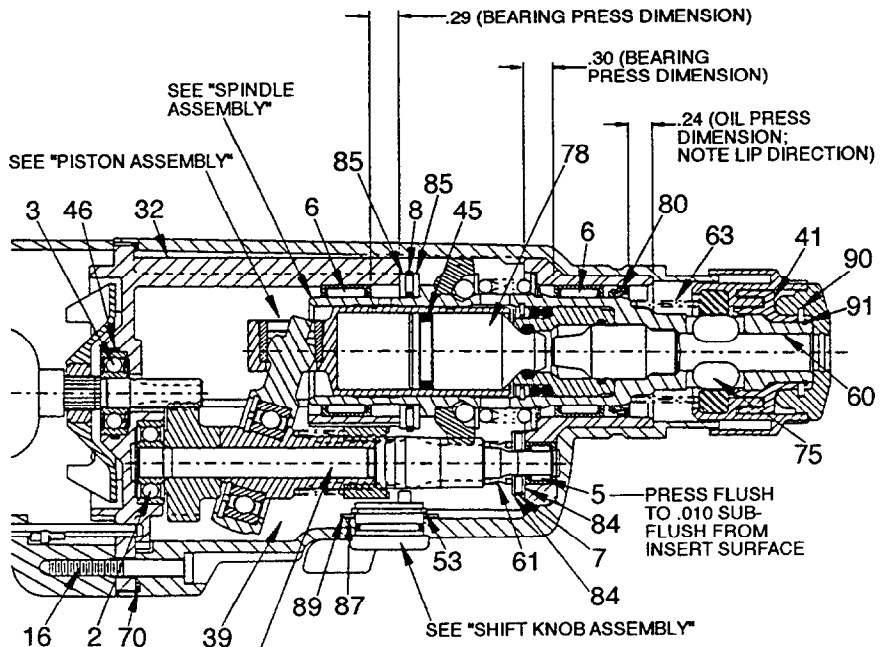

▲ **FILL BEARING BORE OF DIAPHRAGM APPROXIMATELY 1/3 FULL OF GREASE PRIOR TO PRESSING IN BEARING**

▲ **EVENLY DISTRIBUTE 3.5 ± .12 OZ. OF GREASE OVER BOTTOM OF GEARCASE.**

PRESS TO BOTTOM OF HOLE. (GROOVED END FIRST)

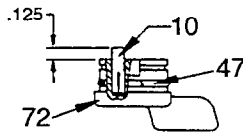

**SHIFT KNOB ASSEMBLY**

ORIENT SLOT AS SHOWN TO WITHIN ±1° AS REFERENCED TO O.D. OF PISTON. PRESS TO BOTTOM OF HOLE

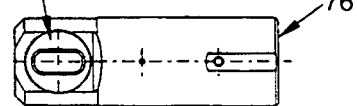

**PISTON ASSEMBLY**

▲ **COAT SPINDLE DETENTS WITH GREASE PRIOR TO ASSEMBLING CLUTCH GEAR. PACK CLUTCH GEAR POCKETS WITH GREASE AFTER ASSEMBLING BALLS AND BEFORE ASSEMBLING WASHER. (SEE GENERAL LUBRICATION NOTES)**

SHARP EDGE OF RETAINING RING TO BE TOWARD REAR (←) OF SPINDLE

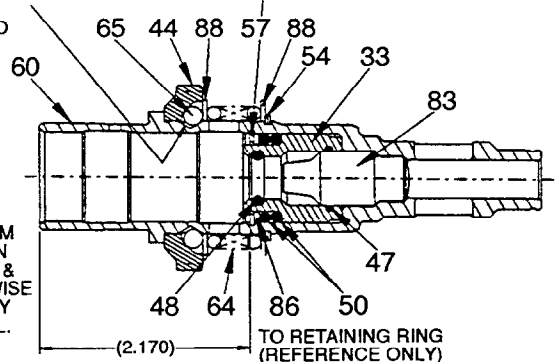

**SPINDLE ASSEMBLY**

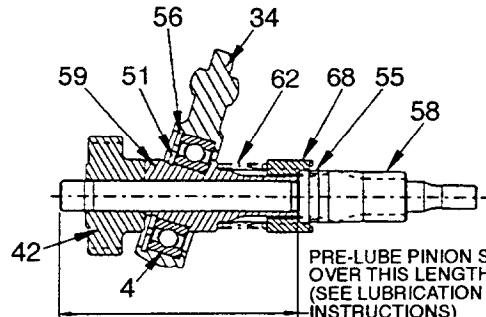

**PINION SHAFT ASSEMBLY**

**NOTE: THE WOBBLE SHAFT #59 AND THE INTERMEDIATE GEAR #42 ARE TO BE PRESSED FLUSH TO EACH OTHER, SO THAT THE WOBBLE SHAFT IS STILL ABLE TO REVOLVE FREELY - WITH .005" MAXIMUM AXIAL PLAY ON THE INTERMEDIATE SHAFT #43.**