

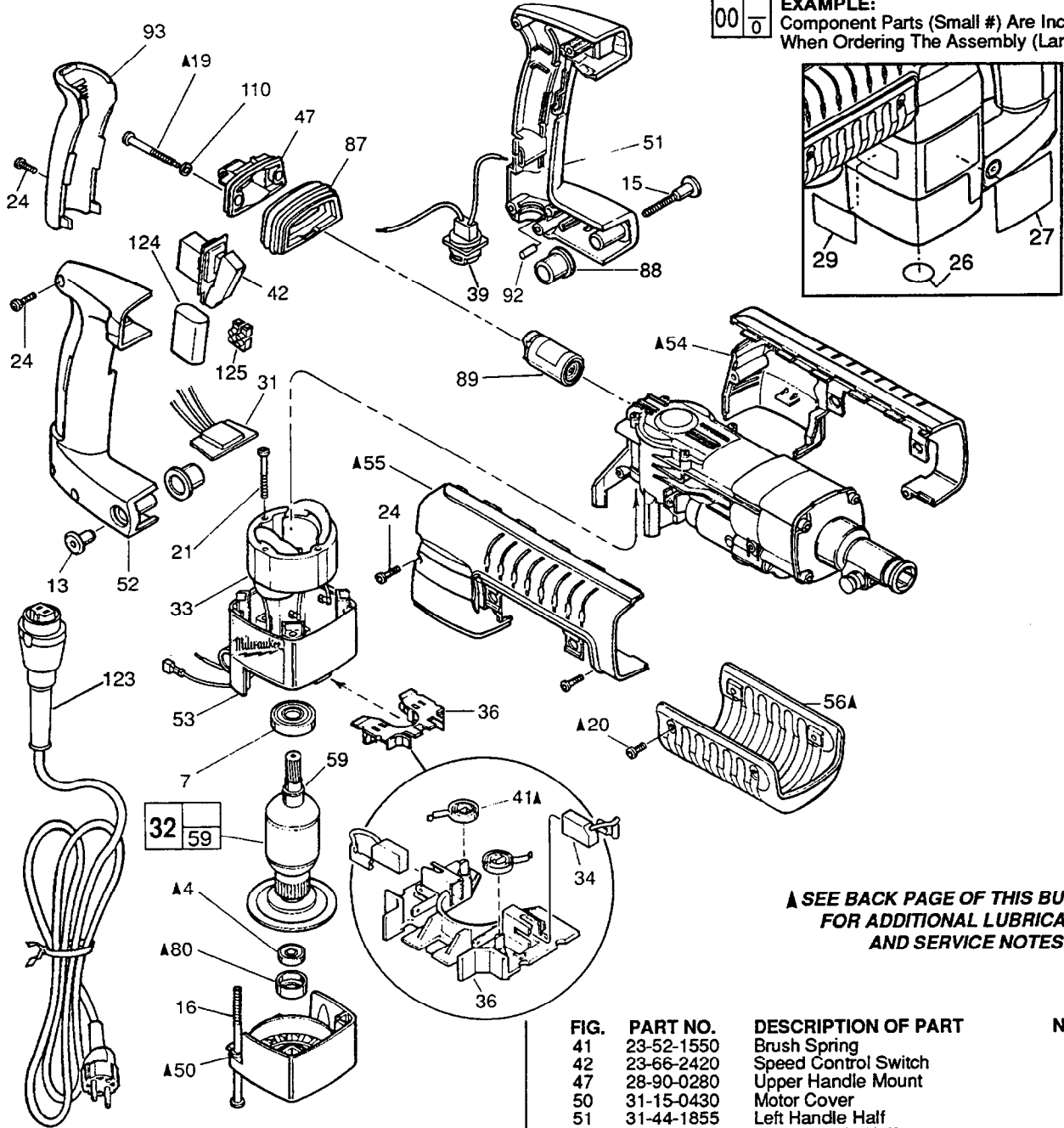

SERVICE PARTS LIST

SPECIFY CATALOG NO. AND SERIAL NO. WHEN ORDERING PARTS		REVISED BULLETIN	DATE
LIGHT CHIPPER HAMMER			Oct. '97
CATALOG NO. 5334-51	STARTING SERIAL NO. 881A	WIRING INSTRUCTION 58-03-1770	

EXAMPLE:
 Component Parts (Small #) Are Included
 When Ordering The Assembly (Large #).



**▲ SEE BACK PAGE OF THIS BULLETIN
 FOR ADDITIONAL LUBRICATION
 AND SERVICE NOTES**

FIG.	PART NO.	DESCRIPTION OF PART	NO. REQ.
4	02-04-0847	Ball Bearing	(1)
7	02-04-1518	Ball Bearing	(1)
13	05-59-0100	Pivot Nut	(1)
15	05-77-0100	Pivot Bolt	(1)
16	05-81-0920	M6 x 1.0 x 120 Pan Hd. Slit. Tapt. T-27	(4)
19	06-81-1805	Special Screw	(2)
20	06-82-7252	8-32 x 3/8" Pan Hd. Slit. Tapt. T-20	(2)
21	06-82-7425	8-16 x 2" Pan Hd. Slit. Plast. T-20	(4)
24	06-95-6290	M5 x 2.24 x 18 Pan Hd. Slit. PT T-20	(7)
26	10-75-2760	Milwaukee Label	(1)
27	10-98-5316	Product Label	(1)
29	12-20-3305	Service Nameplate Kit	(1)
31	14-20-0735	Remote Trigger Speed Control	(1)
32	16-54-1261	Armature	(1)
33	18-54-0260	Field	(1)
34	22-18-0875	Carbon Brush (2) Kit	(1)
36	22-22-1480	Brush Carrier Assembly	(1)
39	22-56-0693	Blade Housing Assembly	(1)

FIG.	PART NO.	DESCRIPTION OF PART	NO. REQ.
41	23-52-1550	Brush Spring	(2)
42	23-66-2420	Speed Control Switch	(1)
47	28-90-0280	Upper Handle Mount	(1)
50	31-15-0430	Motor Cover	(1)
51	31-44-1855	Left Handle Half	(1)
52	31-44-1860	Right Handle Half	(1)
53	31-50-0530	Motor Housing	(1)
54	31-55-0240	Left Shroud	(1)
55	31-55-0250	Right Shroud	(1)
56	31-55-0225	Belly Shroud	(1)
59	34-60-3620	Retaining Ring	(1)
80	42-96-0130	Bearing Cup	(1)
87	43-87-0030	Isolation Bellows	(1)
88	43-87-0040	Pivot Isolator	(2)
89	43-87-0060	Isolation Module Assembly	(1)
92	14-46-1001	Foam Slug Kit (Bag of 10)	(1)
93	44-52-0580	Handle Cushion	(1)
110	45-88-8555	Rubber Washer	(2)
123	48-76-5012	Quik-Lok Cord Set	(1)
124	22-33-0510	Suppressor	(1)
125	22-56-0451	Terminal Block	(1)

MILWAUKEE ELECTRIC TOOL CORPORATION
 13135 W. LISBON RD., BROOKFIELD, WI 53005

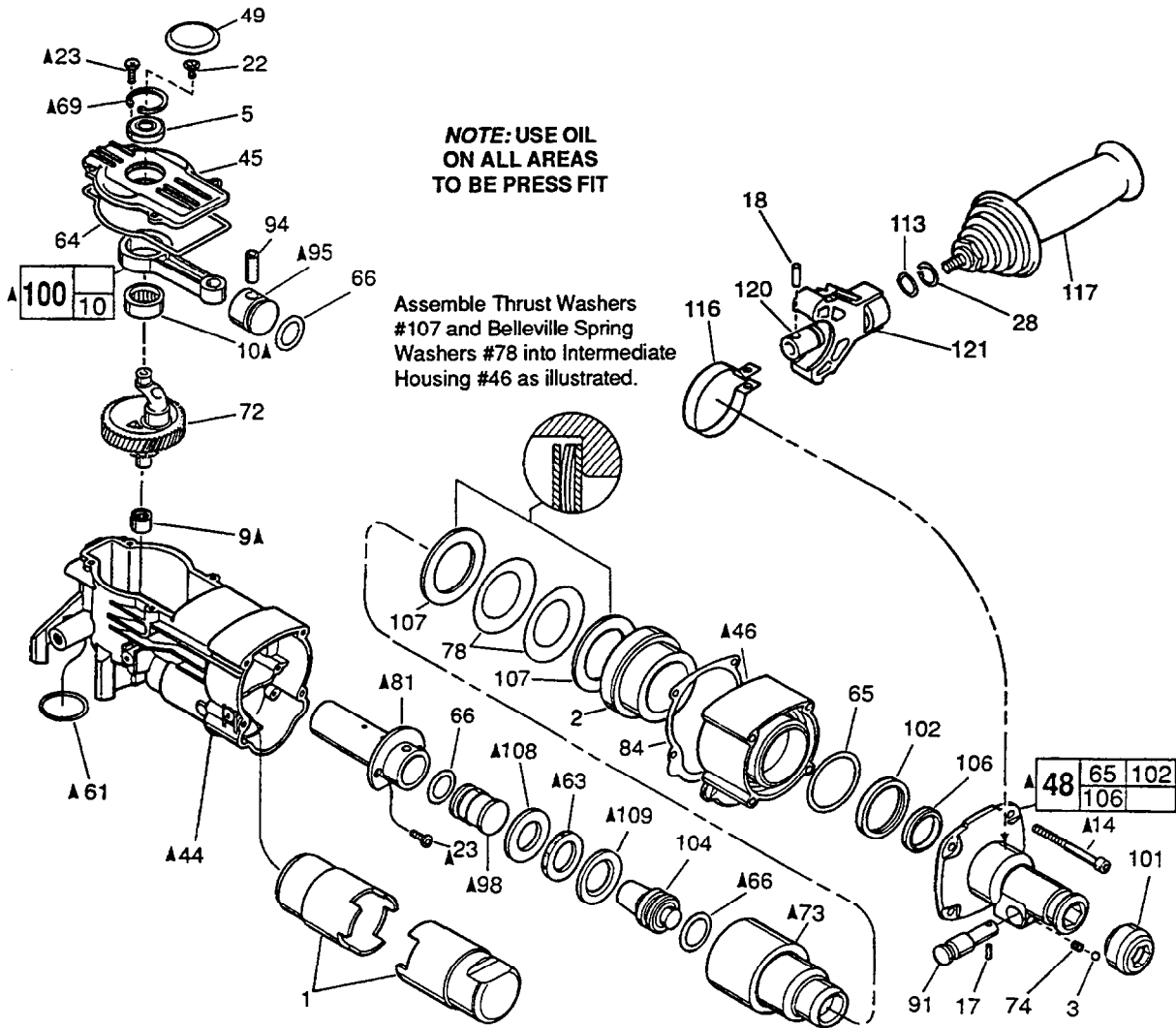

FASTENER TORQUE SPECIFICATIONS (IN./LBS.)

FIG. NO.	SEATING TORQUE		
	MINIMUM	MAXIMUM	
14	120	140	
15	20	25	
16	30	35	
19	30	35	
20	25	30	
21	20	25	
22	25	30	
23	BARREL	30	35
	CRANKCASE COVER	25	30
24	HANDLE HALVES AND SHROUDS	20	25
	CUSHION GRIP	10	15
25		35	45

22-18-0875 CARBON BRUSH SERVICE KIT

THIS KIT CONTAINS:

- 2 Carbon Brush

● 14-46-9070 1-1/2" HAMMER SERVICE KIT

THIS KIT CONTAINS:

- 1 31-12-0270 Cap-Cover
- 1 34-40-4310 Rubber Damping Washer
- 1 34-40-4320 Seal-Cover
- 1 34-40-4330 O-Ring
- 3 34-40-4350 O-Ring
- 1 42-96-0130 Bearing Cup
- 1 43-44-0970 Gasket
- 1 45-06-0540 Dust Seal-Hex
- 1 49-08-4230 6 Oz. Tube "N" Grease

▲ SEE BACK PAGE OF THIS BULLETIN FOR ADDITIONAL LUBRICATION AND SERVICE NOTES

FIG.	PART NO.	DESCRIPTION OF PART	NO. REQ.
1	31-01-0030	Grease Displacer	(2)
2	45-60-0615	Spindle Support	(1)
3	02-02-0250	1/4" Steel Ball	(1)
5	02-04-0911	Ball Bearing	(1)
9	02-50-2470	Needle Bearing	(1)
10	02-50-4020	Needle Bearing	(1)
14	05-81-0830	M6 x 1.0 x 70 Pan Hd. Mach. Scr. T-27	(4)
17	06-65-0828	Groove Pin	(1)
18	06-65-1660	Dowel Pin	(1)
22	06-82-8842	8-32 x 3/8" Pan Hd. Sl. Taptite T-20	(1)
23	06-95-6280	M4 x 0.7 x 14 Pan Hd. Sl. Taptite T-20	(6)
28	34-60-2580	External Retaining Ring	(1)
44	28-14-2285	Crankcase	(1)
45	28-20-1325	Crankcase Cover	(1)
46	28-50-6445	Intermediate Housing	(1)
48	14-52-0020	Nose Assembly	(1)
49	31-12-0270	Cap-Cover	(1)
61	34-40-1375	O-Ring	(1)
63	34-40-4310	Rubber Damping Washer	(1)
64	34-40-4320	Seal-Cover	(1)
65	34-40-4330	O-Ring	(1)
66	34-40-4350	O-Ring	(3)
69	34-80-5090	Retaining Ring-Beveled	(1)
72	14-09-0150	Crankshaft Assembly	(1)
73	38-50-6060	Spindle	(1)
74	40-50-8420	Bit Lock Spring	(1)
78	40-50-8590	Belleville Spring	(2)
81	42-98-0200	Barrel	(1)
84	43-44-0970	Gasket	(1)
91	44-20-0222	Bit Lock	(1)
94	44-60-1400	Wrist Pin	(1)
95	44-62-0210	Piston	(1)
98	44-82-0170	Ram	(1)
100	44-94-0395	Connecting Rod Assembly	(1)
101	49-62-0095	Dust Seal-Hex (5/pkg.)	(1)
102	45-06-0560	Oil Seal	(1)
104	45-56-2610	Striker	(1)
106	45-88-5176	Felt Seal	(1)
107	45-88-8520	Thrust Washer	(2)
108	45-88-8530	Barrel Thrust Washer	(1)
109	45-88-8535	Striker Cushion Washer	(1)
113	45-88-8730	Wave Washer	(1)
115	06-14-0065	Hex Head Bolt-Special	(1)
116	42-16-0150	Side Handle Band	(1)
117	14-34-0515	Side Handle Assembly	(1)
120	44-86-0620	Band Retainer	(1)
121	31-44-2020	Side Handle Housing	(1)

61-10-0670 Nose Service Tool

NOTE: Check the clutch torque. Clutch must slip at 30 to 40 ft.-lbs. at the spindle, checked clockwise as viewed from the front of the tool.

▲ SEE BACK PAGE OF THIS BULLETIN FOR ADDITIONAL LUBRICATION AND SERVICE NOTES

LUBRICATION NOTES: (TYPE "N" GREASE, NO. 49-08-4230)

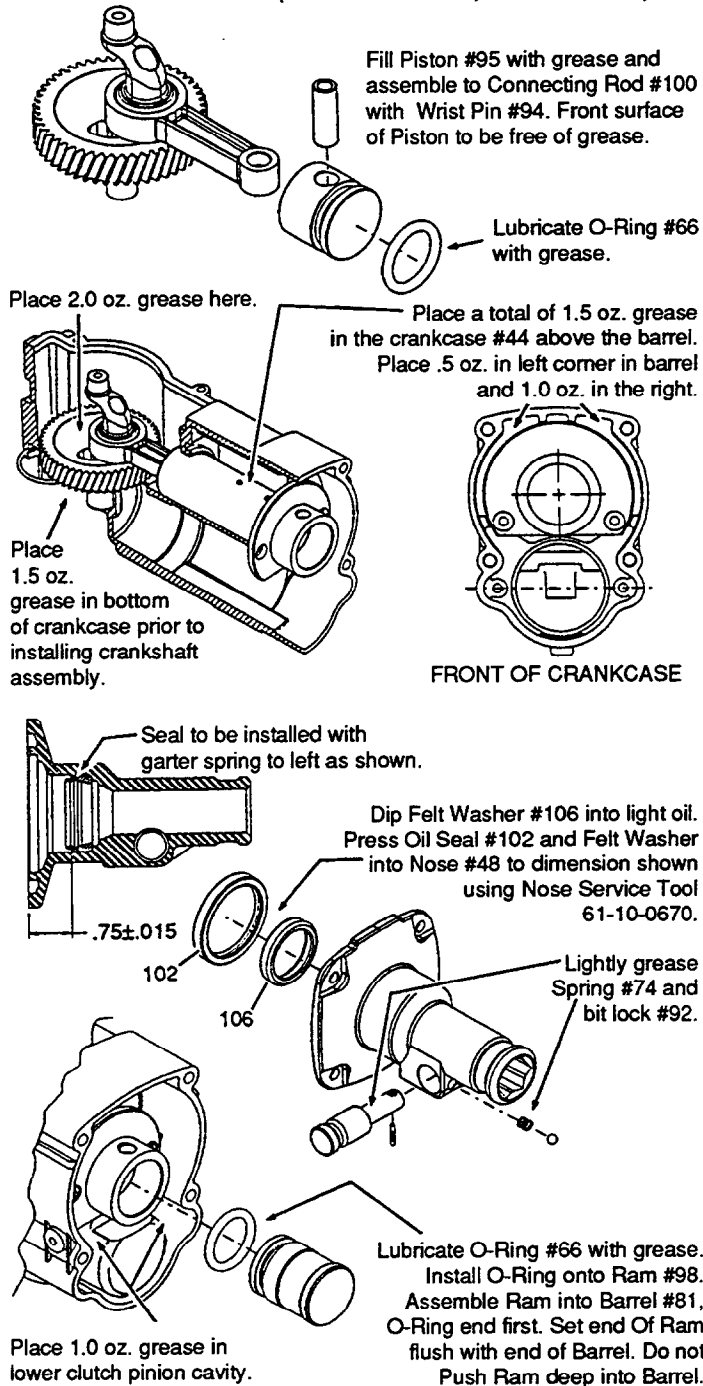

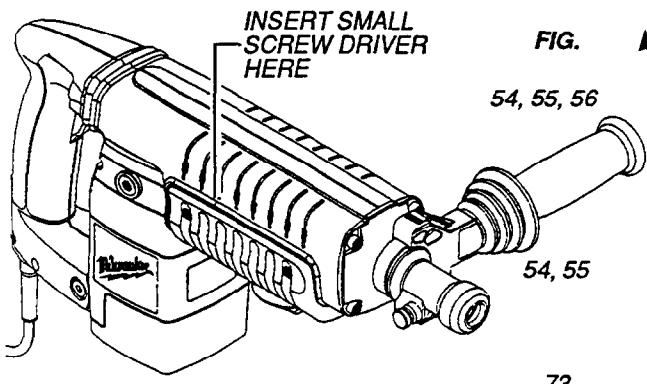

FIG. ▲ NOTES

54, 55, 56 TO REMOVE BELLY SHROUD #56 FROM TOOL, INSERT SMALL SCREW DRIVER INTO GROOVE BETWEEN BELLY AND SIDE SHROUDS #54 AND #55, ABOUT 1/3 OF THE WAY FROM THE MOTOR END, AS SHOWN. PRY OUT AND DOWN ON BOTH SIDES OF THE TOOL.

54, 55 TO INSTALL THE SIDE SHROUDS #54 AND #55, THE TOP HINGE OF THE SHROUDS MUST BE COMPLETELY INTERLOCKED, THEN THE BACK SIDE ROTATED CLOSED AROUND THE TOOL.

73 LUBRICATE ALL BORES IN SPINDLE #73 WITH A MEDIUM COATING OF GREASE.

63, 108, 109 LUBRICATE RUBBER DAMPING WASHER #63, BARREL THRUST WASHER #108 AND STRIKER CUSHION WASHER #109 WITH A MEDIUM COATING OF GREASE BEFORE ASSEMBLY.

10, 100 PRESS NEEDLE BEARING #10 IN ROD #100 SO THAT THE SAME AMOUNT STICKS OUT ON BOTH SIDES OF THE ROD, AS SHOWN.

9, 44 PRESS NEEDLE BEARING #9 INTO CRANKCASE #44, FLUSH WITH TOP OF BORE, AS SHOWN.

81 LIGHTLY GREASE INSIDE OF BARREL #81 BEFORE ASSEMBLY.

48, 73 SMALL OUTSIDE DIAMETER OF SPINDLE #73 IS TO BE LUBRICATED WITH A LIGHT COAT OF GREASE BEFORE ASSEMBLING THE NOSE ASSEMBLY #48 TO THE TOOL.

48, 73, 102 NOSE ASSEMBLY #48 MUST BE PLACED SQUARELY OVER SPINDLE #73, WHEN ASSEMBLING, TO PREVENT DAMAGE TO OIL SEAL #102.

14, 19, 20, 23 FASTENERS #14, #19, #20 AND #23 ARE TO BE RE-ASSEMBLED USING BLUE LOCTITE.

48, 102 LUBRICATE BORE IN NOSE ASSEMBLY #48 BEFORE PRESSING OIL SEAL #102 INTO PLACE.

61, 66 LUBRICATE O-RINGS #61 AND #66 WITH GREASE.

69 INSTALL BEVEL SNAP RING #69 WITH BEVEL SIDE UP.

4, 50, 80 PLACE BEARING CUP #80 ON SMALL ARMATURE BEARING #4 BEFORE INSTALLING MOTOR COVER #50.

41 BRUSH SPRINGS #41 ARE TO BE WOUND 1/2 TURN TO ENGAGE BRUSHES.

4 RUBBER SEAL SIDE OF BALL BEARING #4 TO FACE FAN.

95, 98 FACES OF PISTON #95 AND RAM #98 ARE TO BE FREE OF GREASE.

