



SERVICE PARTS LIST

BULLETIN NO.
55-24-0600

SPECIFY CATALOG NO. AND SERIAL NO. WHEN ORDERING PARTS		REVISED BULLETIN	DATE
16mm ROTARY HAMMER			Dec. '99
CATALOG NO. 5320-51	SERIAL NUMBER 941A	WIRING INSTRUCTION 58-03-1135	

EXAMPLE:
Component Parts (Small #) Are Included
When Ordering The Assembly (Large #).

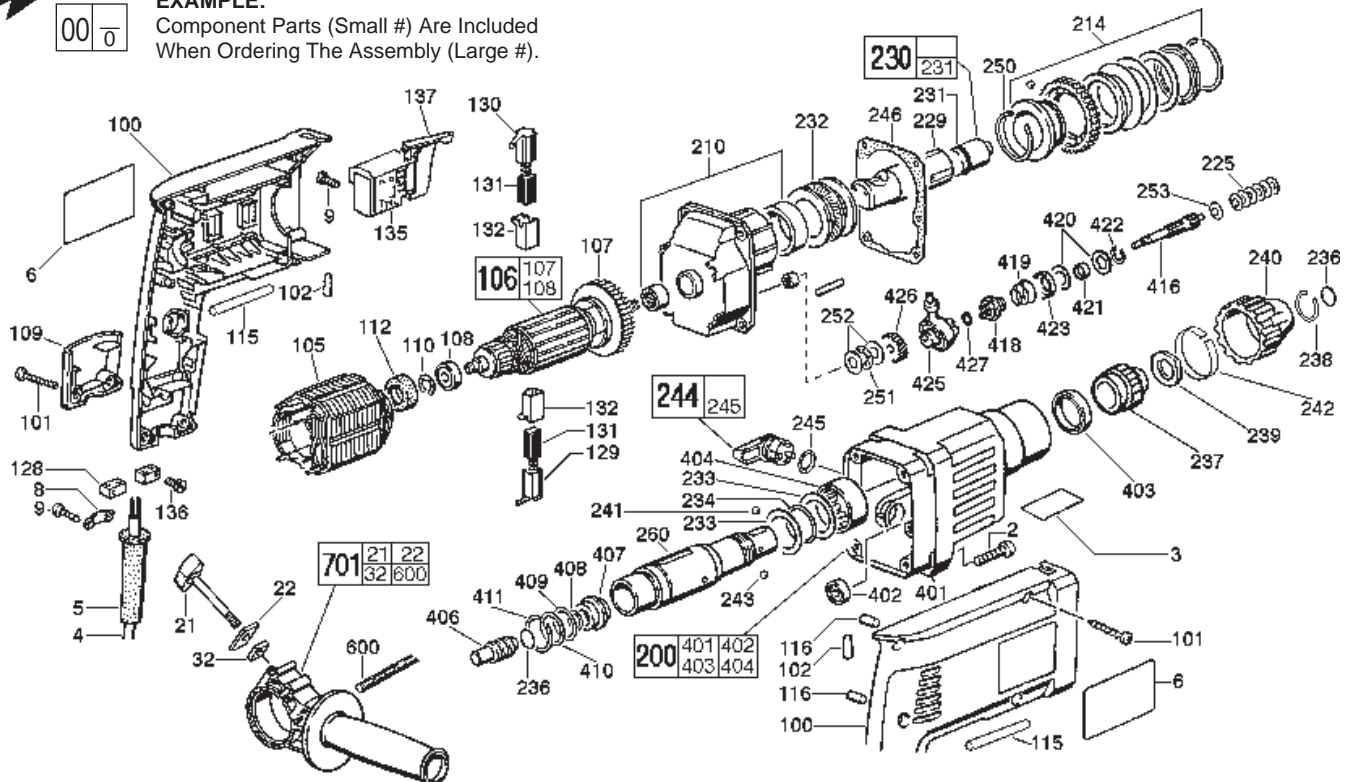

FIG.	PART NO.	DESCRIPTION OF PART	NO. REQ.	FIG.	PART NO.	DESCRIPTION OF PART	NO. REQ.
2	05-81-0955	Screw	4	238	44-90-4410	Retaining Ring	1
3	12-20-0426	Service Nameplate Kit	1	239	42-36-0455	Support Plate	1
4	22-64-0906	Cord Set	1	240	42-76-0665	Chuck Collar	1
5	44-76-0280	Strain Relief	1	241	02-02-1300	Ball 5MM	2
6	10-07-6195	Product Label	2	242	40-50-6905	Spring	1
8	31-17-0240	Cord Clamp	1	243	02-02-0275	Ball 7MM	1
9	05-81-0930	Screw	2	244	44-10-0070	Shift Lever	1
21	05-81-0945	Side Handle Screw	1	245	34-40-0135	O-Ring	1
22	44-66-5665	Clamping Plate	1	246	43-44-1035	Gasket	1
32	44-40-0745	Nut	1	250	44-90-0350	Snap Ring (Int.)	1
100	31-50-0650	Motor Housing - Set	1	251	02-80-0160	Thrust Bearing	1
101	05-88-9601	Screw	6	252	45-88-8285	Thrust Washer	2
102	45-30-0195	Vinyl Slug	2	253	45-88-8820	Thrust Washer	1
105	18-07-0170	Field - Service	1	260	38-50-0025	Spindle	1
106	16-07-0095	Armature - Service	1	401	31-76-0010	Gearcase Shroud	1
107	22-84-0755	Fan	1	402	02-04-1840	Ball Bearing	1
108	02-04-1835	Ball Bearing	1	403	44-90-0003	Seal Ring	1
109	31-15-0155	Servicing Lid	1	404	45-22-0450	Sleeve	1
110	44-90-0340	Snap Ring (Ext.)	1	406	45-56-2530	Striker	1
112	45-22-0580	Rubber Sleeve	1	407	42-76-0720	Thrust Collar	1
115	45-30-0065	Support Slug	2	408	44-90-0002	Seal Ring	1
116	45-30-0200	Vinyl Slug	2	409	34-40-0140	O-Ring	1
120	23-94-1015	Wire	1	410	45-88-1230	Washer	1
122	23-94-1005	Wire	1	411	44-90-0345	Snap Ring (Ext.)	1
123	23-94-1010	Wire	1	416	36-66-4245	Intermediate Shaft	1
127	23-94-1020	Wire	2	418	45-22-0305	Coupling Sleeve	1
128	42-86-0150	Connector	2	419	40-50-8885	Spring	1
129	22-20-0380	Brush Tube	1	420	45-88-8275	Thrust Washer	2
130	22-20-0375	Brush Tube	1	421	45-22-0455	Sleeve	1
131	22-18-0990	Brush (2) Service Kit	1	422	44-90-0355	Snap Ring (Ext.)	1
132	22-20-0225	Brush Holder	2	423	45-88-1235	Washer	1
135	23-66-0046	Switch	1	425	44-66-6095	Wobble Plate	1
136	05-81-0940	Screw	4	426	32-60-2615	Reduction Gear	1
137	44-10-0060	Switch Lever	1	427	45-88-1240	Washer	1
200	31-40-0015	Gearcase	1	600	43-46-0170	Depth Gauge	1
210	44-66-1000	Bearing End Plate Assembly	1	701	49-15-0305	Side Handle	1
214	14-29-0075	Spindle Gear Assembly	1		14-46-4325	Lubrication Service Kit	1
225	40-50-7965	Belleville Spring	6				
229	44-62-0140	Piston	1				
230	44-82-0185	Ram	1				
231	44-90-0001	Seal Ring	1				
232	02-80-0145	Thrust Bearing	1				
233	45-88-1225	Washer	2				
234	34-40-0125	O-Ring	1				
236	34-40-0130	O-Ring	1				
237	45-36-0565	Spacer	1				

SEE REVERSE SIDE FOR SERVICE NOTES

MILWAUKEE ELECTRIC TOOL CORPORATION
13135 W. LISBON RD., BROOKFIELD, WI 53005

SERVICE NOTES:

5320-51

1. To remove striker from spindle, place a pin (9.5mm diameter by 100mm long) in the bit end of the spindle and press out the parts. The locking ring, washer and o-ring will be destroyed and must be replaced.
2. Lubricate all mechanical parts per the instruction in the lubrication service kit.
3. Grease all o-ring grooves before assembling o-ring into them.
4. Gearcase mounting screws must be removed and the gearcase separated from the motor housing about 7mm before the handle/motor housing halves can be separated for motor or brush service. The gearcase can be removed while leaving the armature in position.
5. When reassembling the wobble shaft a clearance of .02 to .08mm must be maintained between the drive gear and the inner race of the wobble plate. The ground side of the gear must face the wobble plate.

