



SERVICE PARTS LIST

BULLETIN NO.
55-24-1650

SPECIFY CATALOG NO. AND SERIAL NO. WHEN ORDERING PARTS		REVISED BULLETIN	DATE
1-9/16" (40mm) SDS-Max Rotary Hammer			Mar. 2015
CATALOG NO.	5317-59A	WIRING INSTRUCTION	
STARTING SERIAL NO.	C86A	SEE PAGE 4	

EXAMPLE:

00	0
----	---

 Component Parts (Small #) Are Included When Ordering The Assembly (Large #).

FIG.	PART NO.	DESCRIPTION OF PART	NO. REQ.
20	43-62-5316	Side Handle Assembly	(1)
20a	42-68-5316	Clamping Band	(1)
20b	06-54-5316	M8 x 6.5mm Square Nut	(1)
20c	44-40-5316	Clamp Holder	(1)
20d	43-98-5316	Side Handle	(1)
21a	05-78-5316	M4 x 14mm Pan Hd. Taptite T-20 (1 of 3)	(1)
22	42-36-5316	Belly Shroud	(1)
23	31-40-5316	Gearcase Assembly	(1)
24	14-46-5311	Ball Bearing and Rotary Seal Assembly	(1)
24a	45-06-5320	Rotary Seal	(1)
24b	34-40-5320	O-Ring	(1)
24c	02-04-5317	Ball Bearing	(1)
24d	45-88-5313	Snap Ring	(1)

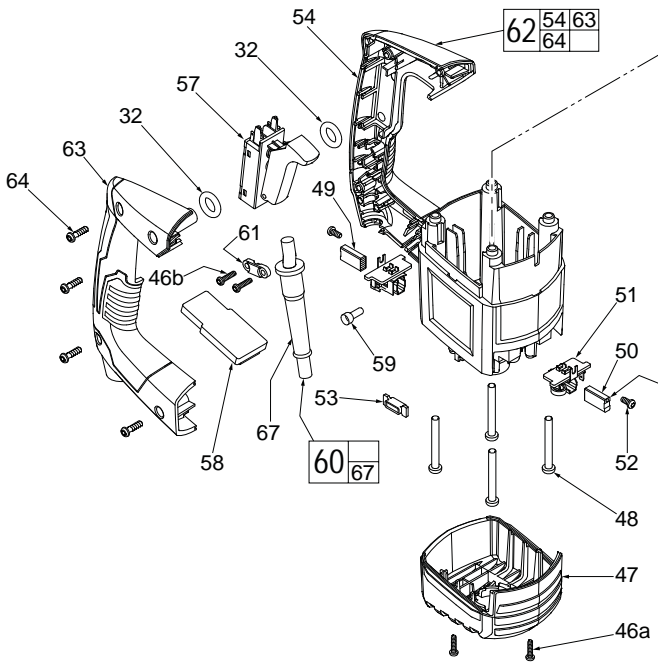
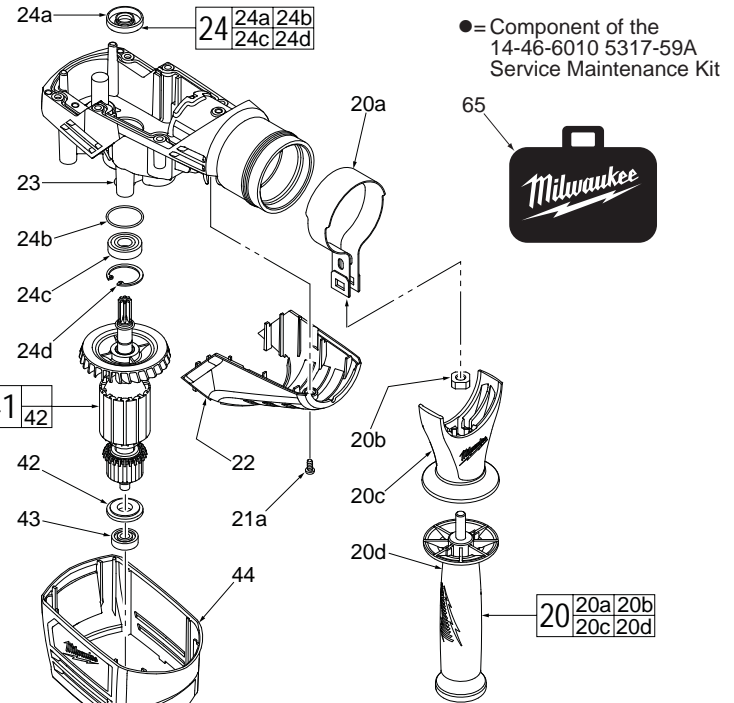

FIG.	PART NO.	DESCRIPTION OF PART	NO. REQ.
32	34-40-5308	O-Ring	(2)
41	16-07-5318	Service Armature	(1)
42	-----	Magnet Ring	(1)
43	02-04-0530	Ball Bearing	(1)
44	23-16-5316	Motor Shroud	(1)
45	31-05-5316	Baffle	(1)
46a	06-82-0995	M4 x 16mm Pan Hd. Plastite T-20	(2)
46b	06-82-0995	M4 x 16mm Pan Hd. Plastite T-20	(2)
47	31-15-5316	Motor End Cover	(1)
48	06-95-5316	M6 x 50mm Pan Hd. Taptite T-30	(4)
49	-----	Carbon Brush Assembly	(1)
50	-----	Carbon Brush Assembly with Cut-Off	(1)
51	22-20-5316	Brush Holder Assembly	(2)
52	05-78-5313	M4 x 9mm Pan Hd. Plastite T-15	(2)
53	43-83-5317	Inductor Assembly	(1)
54	-----	Motor Housing	(1)
55	18-07-5318	Service Field	(1)
56	05-78-5314	M4.5 x 56mm ST T-30	(2)
57	23-66-5315	Trigger Switch	(1)
58	22-09-5318	PCB Assembly	(1)
59	22-56-5317	Close End Connector	(1)
60	22-64-5315	Power Cord with Strain Relief	(1)

FIG.	PART NO.	DESCRIPTION OF PART	NO. REQ.
61	31-17-0155	Cord Clamp	(1)
62	31-40-5317	Motor Housing and Handle Cover Assembly	(1)
63	-----	Handle Cover	(1)
64	05-78-5311	M5 x 18mm ST Pan Hd. Plastite T-20	(4)
65	42-55-5317	Carrying Case	(1)
66	22-18-6030	Brush Service Kit (Set of 2)	(1)
67	44-76-0210	Strain Relief	(1)

• See page 2 for the exploded view and parts listing of the mechanical portion of the tool and service fixtures.

• See page 3 for lubrication instructions, torques chart, maintenance instructions and service kits.

• See Page 4 for wiring instructions.

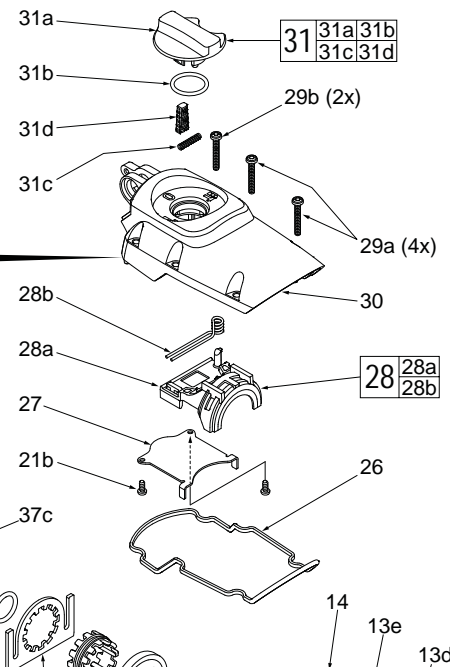
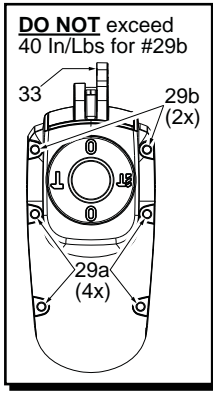
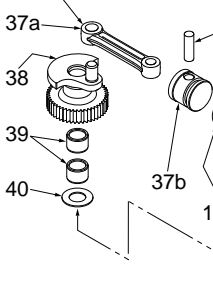
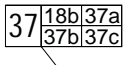

FIG.	PART NO.	DESCRIPTION OF PART	NO. REQ.
18a	45-56-5320	Striker	(1)
18b	34-40-5310	O-Ring	(2)
19	45-88-5314	Washer	(1)
21b	05-78-5316	M4 x 14mm Pan Hd. Taptite T-20 (2 of 3)	(2)
23	31-40-5316	Gearcase Assembly	(1)
25	32-10-5316	Clutch Assembly	(1)
26	45-06-5316	Rubber Gasket	(1)
27	44-66-5313	Selector Bracket Clamp Plate	(1)
28	14-46-5312	Fork Assembly	(1)
28a	-----	Fork	(1)
28b	-----	Fork Assembly Spring	(1)
29a	05-78-5315	M5 x 33mm Pan Hd. Taptite T-25	(4)
29b	05-78-5315	M5 x 33mm Pan Hd. Taptite T-25	(2)
30	28-20-5316	Gearcase Cover	(1)
31	23-66-5316	Selector Knob Assembly	(1)
31a	43-98-5321	Selector Knob	(1)
31b	34-40-5309	O-Ring	(1)
31c	40-50-5320	Spring	(1)
31d	44-62-0710	Rubber Plug	(1)
34	32-75-5316	Spindle Bevel Gear	(1)
35	45-22-5316	Drive Sleeve	(1)
36	44-66-5312	Locking Plate	(1)
37	14-09-5316	Piston and Connecting Rod Assembly	(1)
37a	44-94-0710	Connecting Rod	(1)



There are slightly smaller teeth on one side of drive sleeve #35 that are to face the spindle bevel gear #34.

Be sure to orient the bearing shield #13 with the front notches at the 3:00 and 9:00 position prior to installing in gearcase #23

● = Component of the 14-46-6010 5317-59A Service Maintenance Kit

FIG.	PART NO.	DESCRIPTION OF PART	NO. REQ.
1	45-12-5316	Rubber Dust Shield	(1)
2	45-22-5317	Front Latch Sleeve	(1)
3	34-60-5316	Retaining Ring	(1)
4	45-88-5316	Washer	(1)
5	34-40-5316	Spindle O-Ring	(2)
6	45-88-5321	Washer	(1)
7	45-22-5319	Sliding Collar	(1)
8	45-22-5321	Locking Sleeve	(1)
9	44-66-5316	Front Spring Retainer	(1)
10	40-50-5318	Spring	(1)
11	44-66-5314	Rear Spring Retainer	(1)
12	34-40-5315	Retaining Ring	(1)
13	14-46-5316	Bearing Shield Assembly	(1)
13a	-----	Bearing Shield	(1)
13b	34-40-5321	O-Ring	(2)
13c	45-06-5170	Felt Seal	(1)
13d	45-06-5180	Rotary Seal	(1)
13e	02-50-5316	Bearing Ring	(1)
14	45-88-5323	O-Ring	(1)
15	44-20-5316	Key	(2)
16	42-06-5316	Anvil Assembly	(1)
16a	-----	Anvil	(1)
16b	34-60-5319	O-Ring	(2)
16c	45-06-5317	Turcon Seal	(2)
17	38-50-5316	SDS-Max Spindle Assembly	(1)
17a	44-82-5317	SDS-Max Spindle	(1)
17b	43-06-5317	Brake Ring	(1)
17c	45-88-5325	Rebound Ring	(2)
17d	34-60-5321	Back Press Ring	(1)
17e	44-60-5316	Spindle Sleeve Pin	(6)
17f	44-90-5317	Steel Ring	(1)
17g	44-90-5319	Spring Ring	(1)
17h	38-50-5323	Barrel	(1)
18	45-56-5316	Striker Assembly	(1)

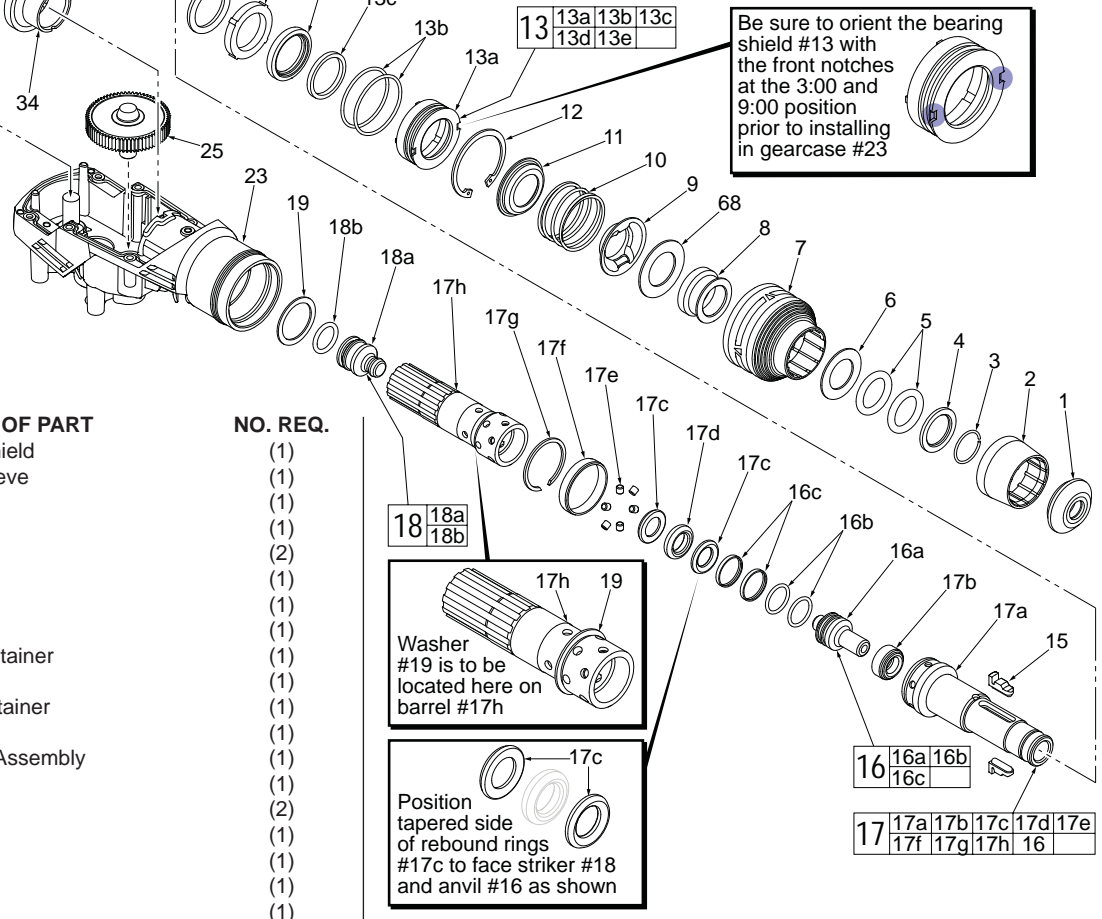

Washer #19 is to be located here on barrel #17h

Position tapered side of rebound rings #17c to face striker #18 and anvil #16 as shown

FIG.	PART NO.	DESCRIPTION OF PART	NO. REQ.
37b	-----	Piston	(1)
37c	-----	Wrist Pin	(1)
38	36-17-5317	Crank Shaft	(1)
39	02-50-5315	Needle Bearing	(2)
40	45-88-5327	Washer	(1)
68	45-88-5371	Washer	(1)

SERVICE FIXTURES FOR THE 5317-20 SDS ROTARY HAMMER

PART NO.	DESCRIPTION OF FIXTURE
61-10-1027	Armature Press Gauge
61-10-1030	Seal Driver
61-10-1032	Seal Expander
61-10-1035	Anvil Insertion Guide
61-10-1037	Seal Driver

Lubrication Note: MILWAUKEE recommends that scheduled maintenance of this Rotary Hammer include lubrication replacement, and replacement of vital O-rings and gaskets at each carbon brush change. Doing so will prolong the life of the hammer by reducing wear to gears and mechanism parts. The carbon brushes and armature commutator in this MILWAUKEE Rotary Hammer are designed and matched for many hours of reliable performance.

Pack the rear of the piston with grease. There is to be no lubrication on the face of the part.

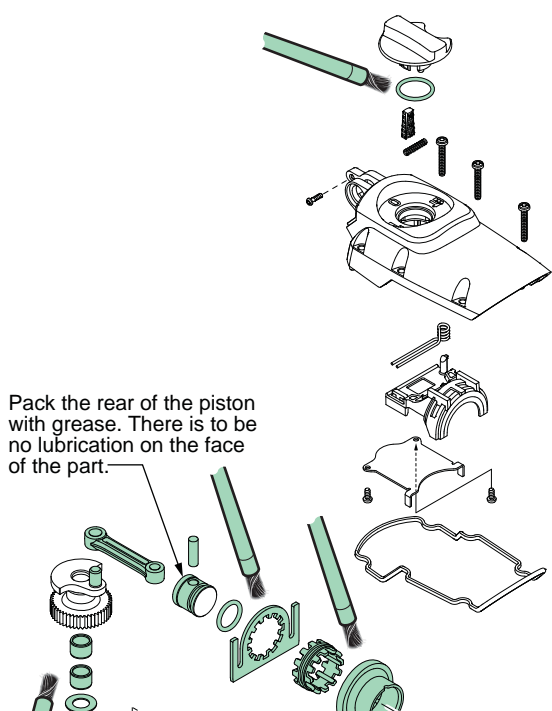

Coat teeth of clutch assembly with grease

Place 2-3/16 oz. (62g) of grease in the bottom of the gearcase

Place 5/8 oz. (18g) of grease in the rear of the barrel before installing the striker

1. Place washer #19 onto backside of barrel.
2. Place 18 grams of 'Q2' grease inside barrel.
3. Coat o-ring groove on ram and o-ring with grease prior to installing o-ring on ram.
Coat the assembled ram and o-ring with grease as shown below.
4. When placing ram assembly into barrel, **slowly** apply pressure to ram assembly.
5. Push the ram assembly until rear face is just below small hole in the barrel. **DO NOT** wipe off any excess grease that oozes out of holes.

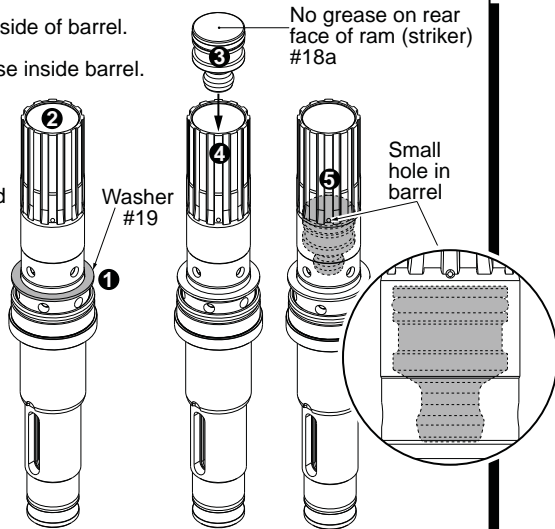

Fig. 1

LUBRICATION NOTES:
Type 'Q2' Grease, No. 49-08-5355 (2.8oz, 80g tube)

Prior to reinstalling, clean gear assemblies with a clean, dry cloth. Lightly coat all individual parts highlighted here with grease. Apply a greater amount of grease to all internal and external gear teeth. Place 18 grams of grease in the rear of the barrel prior to inserting the ram. Place the remaining grease in the bottom of the gearcase.

Coat o-ring and o-ring groove prior to installing o-ring.
With o-ring installed, coat around entire side of ram

Coat the inside of the spindle driver prior to assembly

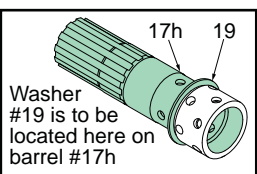

Washer #19 is to be located here on barrel #17h

22-18-6030 BRUSH SERVICE KIT

THIS KIT CONTAINS:

- 1 ----- Carbon Brush
- 1 ----- Carbon Brush with Pop Off

● **14-46-6010 MAINTENANCE SERVICE KIT**

THIS KIT CONTAINS:

- 1 45-12-5316 Rubber Dust Shield
- 1 34-60-5316 Retaining Ring
- 2 34-40-5316 Spindle O-Ring
- 2 34-60-5319 O-Ring
- 2 34-40-5321 O-Ring
- 1 45-06-5170 Felt Seal
- 1 45-06-5180 Rotary Seal
- 1 45-88-5323 O-Ring
- 2 45-06-5317 Turcon Seal
- 1 34-60-5321 Back Press Ring
- 2 34-40-5310 O-Ring
- 1 45-06-5316 Rubber Gasket
- 2 34-40-5308 O-Ring
- 1 22-18-6030 Brush Service Kit (Set of 2)
- 1 49-08-5355 'Q2' Grease (2.8oz/80g tube)

FASTENER TORQUE SPECIFICATIONS (FT./LBS.)

FIG. NO.	WHERE USED	SEATING TORQUE	
		In/Lbs	Nm
21a	Belly Shroud - 1x	19-25	2.2-2.8
21b	Selector Bracket Clamp Plate - 2x	19-25	2.2-2.8
29a	Gearcase Cover (middle & front positions - 4x)	50-55	5.6-6.2
29b	Gearcase Cover (rear position - 2x)	35-40	4.0-4.6
46a	Motor End Cover - 2x	8-12	0.9-1.4
46b	Cord Clamp - 2x	10-16	1.2-1.8
48	Motor Housing - 4x	47-53	5.4-6.0
52	Brush Holder Assemblies - 2x	10-16	1.2-1.8
56	Field - 2x	16-21	1.8-2.4
64	Handle Cover - 4x	23-28	2.6-3.2
	Switch Screw - 2x	3.5-6	0.4-0.7

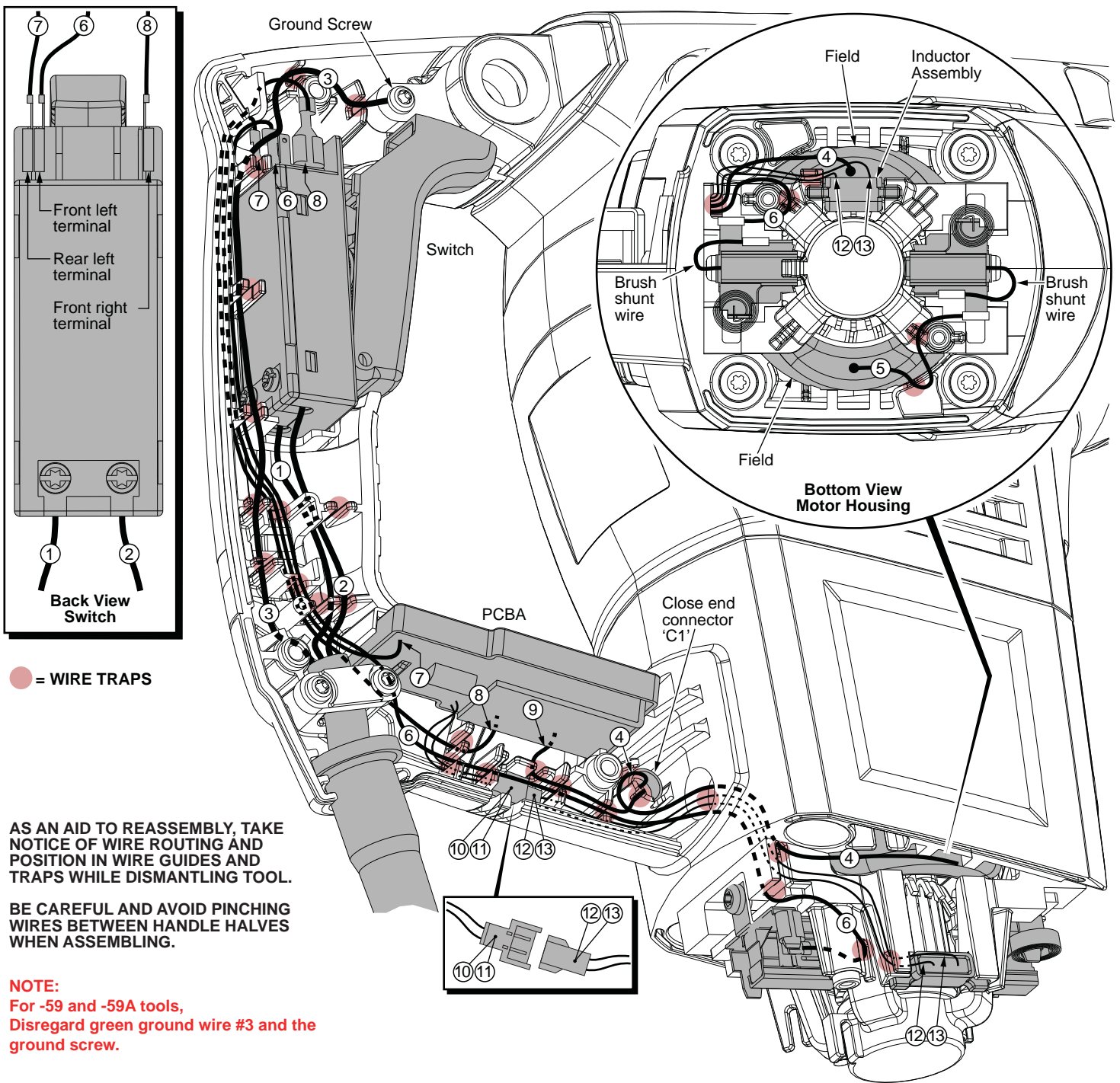

● = WIRE TRAPS

AS AN AID TO REASSEMBLY, TAKE NOTICE OF WIRE ROUTING AND POSITION IN WIRE GUIDES AND TRAPS WHILE DISMANTLING TOOL.

BE CAREFUL AND AVOID PINCHING WIRES BETWEEN HANDLE HALVES WHEN ASSEMBLING.

NOTE:
For -59 and -59A tools,
Disregard green ground wire #3 and the ground screw.

WIRING SPECIFICATIONS

Wire No.	Wire Color	Origin or Gauge	Length	Terminals, Connectors and 1 or 2 End Wire Preparation
1	Blue	22-64-5317	----	Component of cord set. Connect to position 2↓ on bottom of switch.
2	Brown	22-64-5317	----	Component of cord set. Connect to position 1↓ on bottom of switch.
3	Green	----	----	Component of cord set. Route to ground screw at the top of the gearcase cover.
4	White	18-07-5318	----	Component of field. Join with red PCBA wire #9 and secure with close end connector 'C1'.
5	Black	18-07-5318	----	Component of field. Connect to front brush holder assembly. See bottom detail.
6	Black	23-94-5317	----	Leadwire assembly. Connect one end to top front left terminal on switch. Connect other end to back brush holder assy.
7	Black	22-09-5318	----	Component of PCBA. Connect to top rear left terminal on switch.
8	White	22-09-5318	----	Component of PCBA. Connect to top front right terminal on switch.
9	Red	22-09-5318	----	Component of PCBA. Join with white field wire #4 and secure with close end connector 'C1'.
10	Black	22-09-5318	----	Component of PCBA. Joined to female connector with white wire #11. Connect to male connector and wires #12 & 13.
11	White	22-09-5318	----	Component of PCBA. Joined to female connector with white wire #10. Connect to male connector and wires #12 & 13.
12	White	43-83-5318	----	Component of inductor assy. Joined to male connector with red wire #13. Connect to female connector and wires #10 & 11.
13	Red	43-83-5318	----	Component of inductor assy. Joined to male connector with white wire #12. Connect to female connector and wires #10 & 11.