



SERVICE PARTS LIST

SPECIFY CATALOG NO. AND SERIAL NO. WHEN ORDERING PARTS		REVISED BULLETIN 54-24-0400	DATE Jan. '99
1-1/2" THUNDERBOLT™ ROTARY HAMMER			
CATALOG NO.	5311	STARTING SERIAL NO.	844B
			WIRING INSTRUCTION 58-01-1555

00 0

EXAMPLE:
 Component Parts (Small #) Are Included
 When Ordering The Assembly (Large #).

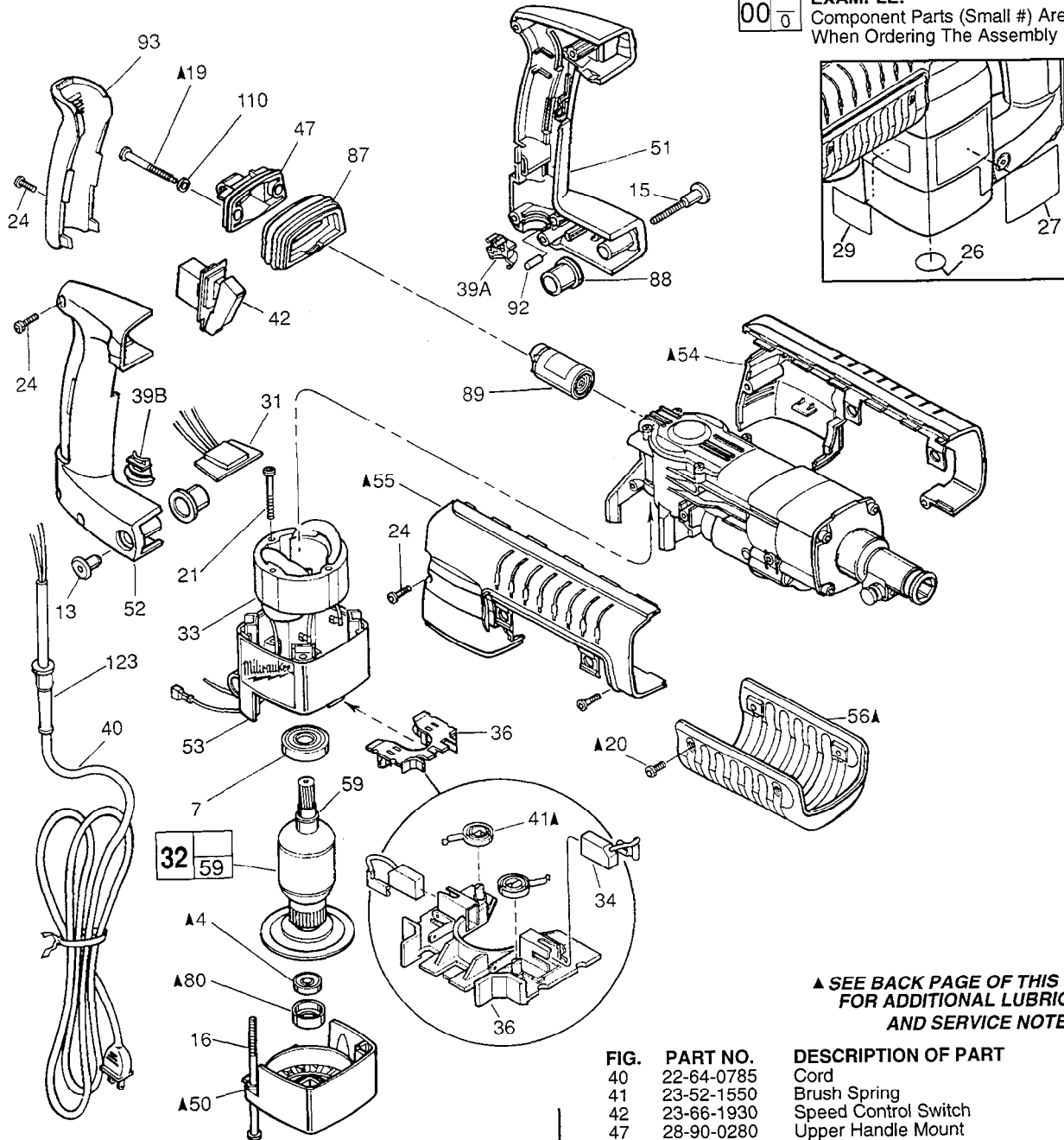

▲ SEE BACK PAGE OF THIS BULLETIN FOR ADDITIONAL LUBRICATION AND SERVICE NOTES

FIG.	PART NO.	DESCRIPTION OF PART	NO. REQ.
	4	Ball Bearing	(1)
★	7	Ball Bearing	(1)
	13	Pivot Nut	(1)
	15	Pivot Bolt	(1)
	16	M6 x 1.0 x 120 Pan Hd. Slit. Tapt. T-27	(4)
	19	Special Screw	(2)
	20	8-32 x 3/8" Pan Hd. Slit. Tapt. T-20	(4)
	21	8-16 x 2" Pan Hd. Slit. Plast. T-20	(2)
	24	M5 x 2.24 x 18 Pan Hd. Slit. PT T-20	(7)
	26	Milwaukee Label	(1)
	27	Product Label	(1)
	29	Service Nameplate Kit	(1)
	31	Remote Trigger Speed Control	(1)
	32	120 Volt Armature	(1)
	33	120 Volt Field	(1)
	34	120 V Carbon Brush (2) Kit	(1)
	36	Brush Carrier Assembly	(1)
	39A	Lower Cord Clamp	(1)
	39B	Upper Cord Clamp	(1)

FIG.	PART NO.	DESCRIPTION OF PART	NO. REQ.
	40	Cord	(1)
	41	Brush Spring	(2)
	42	Speed Control Switch	(1)
	47	Upper Handle Mount	(1)
	50	Motor Cover	(1)
★	51	Left Handle Half	(1)
★	52	Right Handle Half	(1)
	53	Motor Housing	(1)
	54	Left Shroud	(1)
	55	Right Shroud	(1)
	56	Belly Shroud	(1)
	59	Retaining Ring	(1)
	80	Bearing Cup	(1)
	87	Isolation Bellows	(1)
	88	Pivot Isolator	(2)
	89	Isolation Module Assembly	(1)
	92	Foam Slug Kit (Bag of 10)	(1)
	93	Handle Cushion	(1)
	110	Rubber Washer	(2)
	123	Cord Protector	(1)

MILWAUKEE ELECTRIC TOOL CORPORATION
 13135 W. LISBON RD., BROOKFIELD, WI 53005

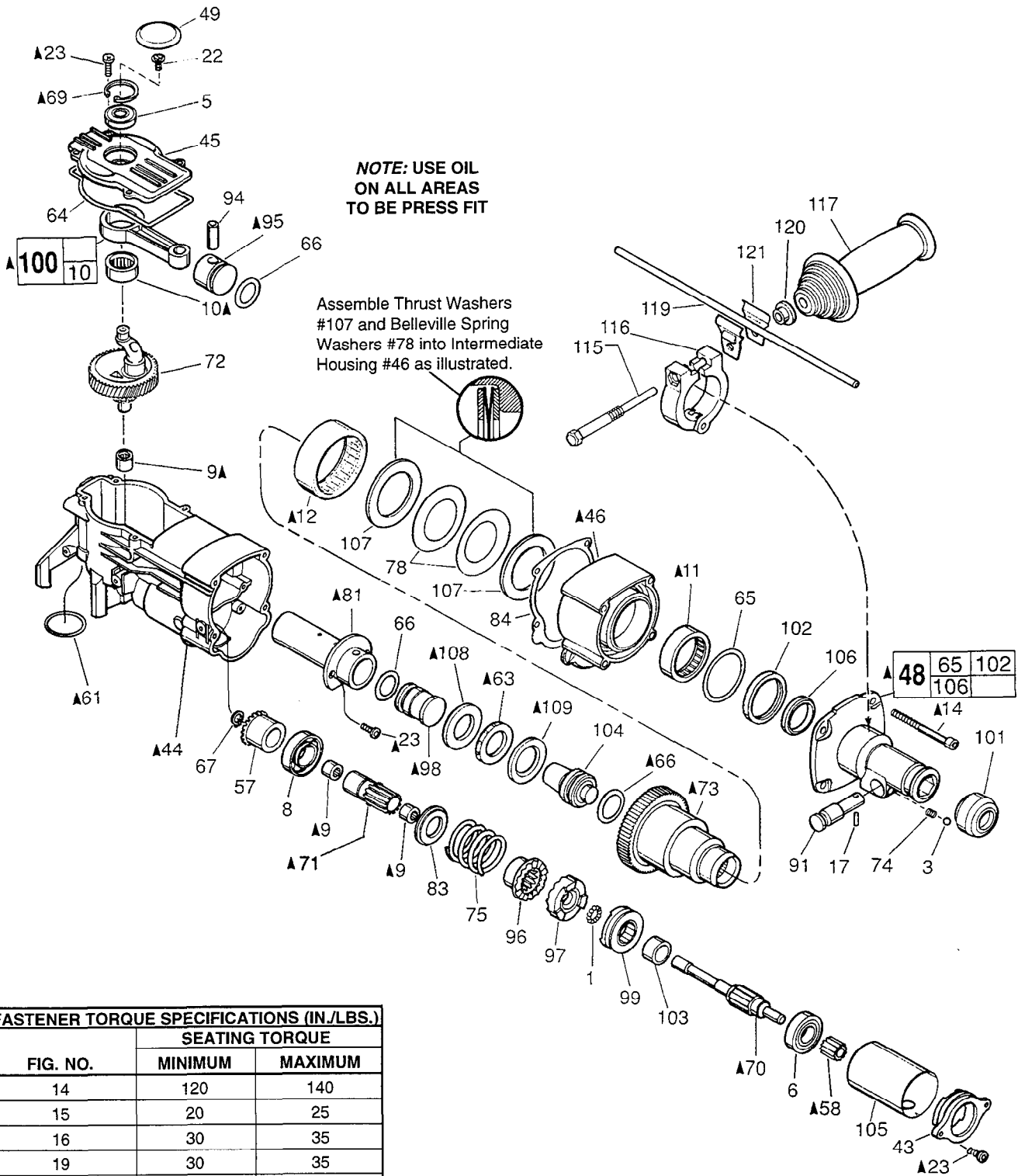

FASTENER TORQUE SPECIFICATIONS (IN./LBS.)

FIG. NO.	SEATING TORQUE	
	MINIMUM	MAXIMUM
14	120	140
15	20	25
16	30	35
19	30	35
20	25	30
21	20	25
22	25	30
23	30	35
23	20	25
23	25	30
24	20	25
24	6	10
25	35	45

22-18-0870 CARBON BRUSH SERVICE KIT

THIS KIT CONTAINS:

- 2 ----- Carbon Brush

● 14-46-9070 1-1/2" HAMMER SERVICE KIT

THIS KIT CONTAINS:

- 1 31-12-0270 Cap-Cover
- 1 34-40-4310 Rubber Damping Washer
- 1 34-40-4320 Seal-Cover
- 1 34-40-4330 O-Ring
- 3 34-40-4350 O-Ring
- 1 42-96-0130 Bearing Cup
- 1 43-44-0970 Gasket
- 1 45-06-0540 Dust Seal-Hex
- 1 45-06-0550 Dust Seal-Round
- 1 49-08-4230 6 Oz. Tube "N" Grease

▲ SEE BACK PAGE OF THIS BULLETIN FOR ADDITIONAL LUBRICATION AND SERVICE NOTES

FIG.	PART NO.	DESCRIPTION OF PART	NO. REQ.
1	02-02-0120	1/8" Steel Ball	(12)
3	02-02-0250	1/4" Steel Ball	(1)
5	02-04-0911	Ball Bearing	(1)
6	02-04-1510	Ball Bearing	(1)
8	02-04-2000	Ball Bearing	(1)
9	02-50-2470	Needle Bearing	(3)
10	02-50-4020	Needle Bearing	(1)
11	02-50-9000	Needle Bearing	(1)
12	02-50-9985	Needle Bearing	(1)
14	05-74-0670	M6 x 1.0 x 70 Skt. Hd. Cap Screw T-27	(4)
17	06-65-0828	Groove Pin	(1)
22	06-82-8842	8-32 x 3/8" Pan Hd. Slit. Taptite T-20	(1)
23	06-95-6280	M4 x 0.7 x 14 Pan Hd. Slit. Taptite T-20	(8)
43	28-12-0360	Bearing Retainer	(1)
44	28-14-2255	Crankcase	(1)
45	28-20-1325	Crankcase Cover	(1)
46	28-50-6445	Intermediate Housing	(1)
48	14-52-0020	Nose Assembly	(1)
49	31-12-0270	Cap-Cover	(1)
57	32-05-2250	Bevel Gear	(1)
58	32-60-2590	Clutch Pinion	(1)
61	34-40-1375	O-Ring	(1)
63	34-40-4310	Rubber Damping Washer	(1)
64	34-40-4320	Seal-Cover	(1)
65	34-40-4330	O-Ring	(1)
66	34-40-4350	O-Ring	(3)
67	34-60-0700	Retaining Ring	(1)
69	34-80-5090	Retaining Ring-Beveled	(1)
70	36-14-0760	Clutch Shaft	(1)
★ 71	36-14-0770	Hollow Clutch Shaft	(1)
72	14-09-0140	Crankshaft Assembly	(1)
73	38-50-6030	Spindle	(1)
74	40-50-8420	Bit Lock Spring	(1)
75	40-50-8575	Compression Spring	(1)
78	40-50-8590	Belleville Spring	(2)
81	42-98-0240	Barrel	(1)
83	43-34-0740	Spring Flange	(1)
84	43-44-0970	Gasket	(1)
91	44-20-0222	Bit Lock	(1)
94	44-60-1400	Wrist Pin	(1)
95	44-62-0210	Piston	(1)
96	44-66-6030	Splined Clutch Plate	(1)
★ 97	44-66-6045	Fixed Clutch Plate	(1)
98	44-82-0170	Ram	(1)
99	44-90-4380	Shift Ring	(1)
100	44-94-0395	Connecting Rod Assembly	(1)
101	49-62-0095	Dust Seal-Hex (5/pkg.)	(1)
	49-62-0105	Dust Seal-Round (5/pkg.)	(1)
102	45-06-0560	Oil Seal	(1)
103	45-36-1530	Spacer	(1)
104	45-56-2610	Striker	(1)
★ 105	45-76-0490	Clutch Tube	(1)
106	45-88-5176	Felt Seal	(1)
107	45-88-8520	Thrust Washer	(2)
108	45-88-8530	Barrel Thrust Washer	(1)
109	45-88-8535	Striker Cushion Washer	(1)
115	06-14-0030	Hex Head Cap Screw-Special	(1)
116	14-34-0540	Handle Ring Assembly	(1)
117	14-34-0510	Side Handle Assembly	(1)
119	44-94-0165	Depth Gauge Rod	(1)
120	45-36-1570	Spacer	(1)
121	45-60-0600	Depth Rod Clamp	(2)

61-10-0670 Nose Service Tool

NOTE: Check the clutch torque. Clutch must slip at 30 to 40 ft.-lbs. at the spindle, checked clockwise as viewed from the front of the tool.

▲ SEE BACK PAGE OF THIS BULLETIN FOR ADDITIONAL LUBRICATION AND SERVICE NOTES

LUBRICATION NOTES: (TYPE "N" GREASE, NO. 49-08-4230)

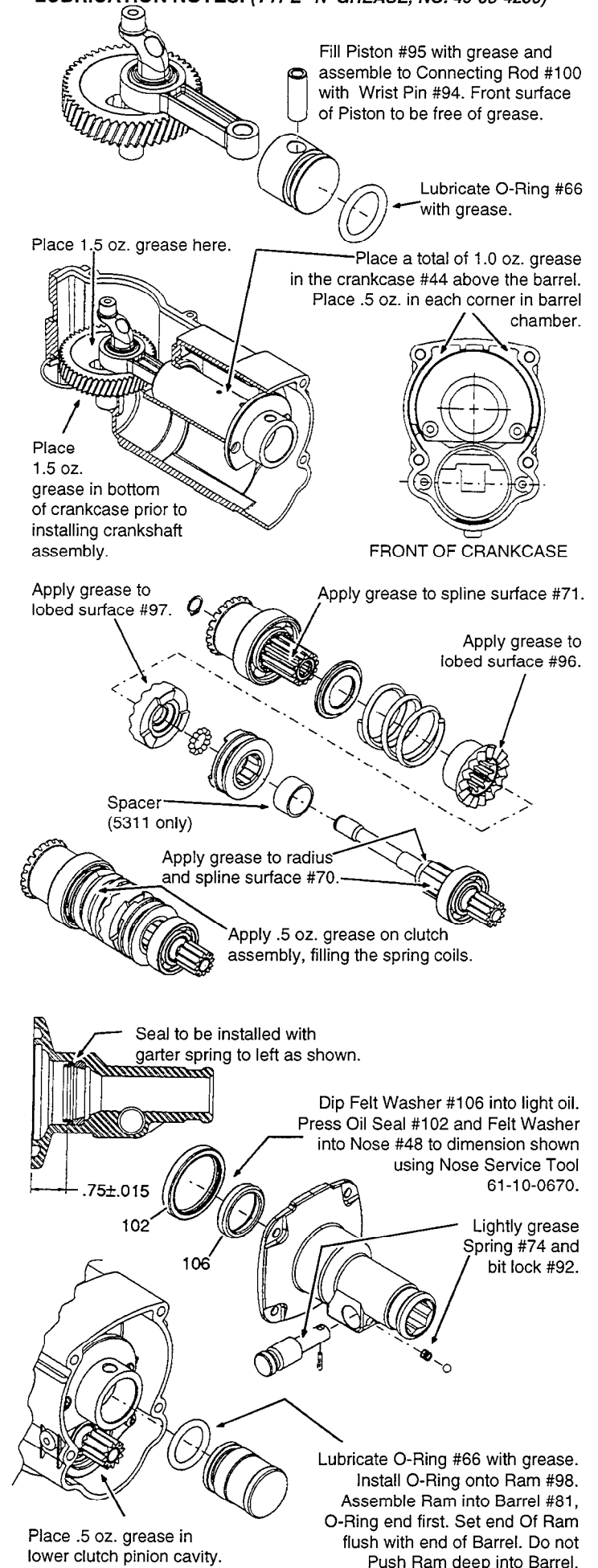
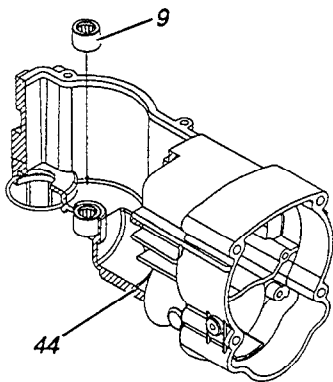
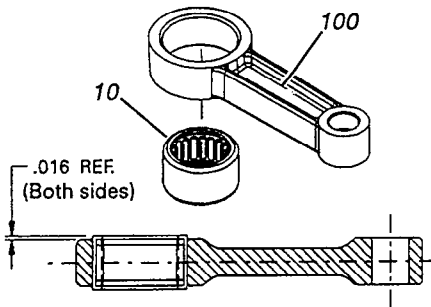
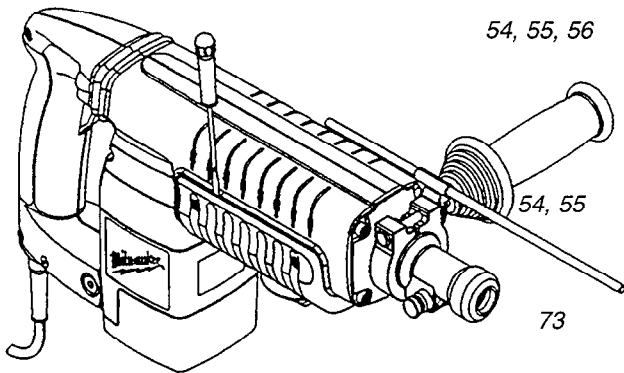

FIG. ▲ NOTES



TO REMOVE BELLY SHROUD #56 FROM TOOL, INSERT SMALL SCREW DRIVER INTO GROOVE BETWEEN BELLY AND SIDE SHROUDS #54 AND #55, ABOUT 1/3 OF THE WAY FROM THE MOTOR END, AS SHOWN. PRY OUT AND DOWN ON BOTH SIDES OF THE TOOL.

TO INSTALL THE SIDE SHROUDS #54 AND #55, THE TOP HINGE OF THE SHROUDS MUST BE COMPLETELY INTERLOCKED, THEN THE BACK SIDE ROTATED CLOSED AROUND THE TOOL.

LUBRICATE ALL BORES IN SPINDLE #73 WITH A MEDIUM COATING OF GREASE.

63, 108, 109 LUBRICATE RUBBER DAMPING WASHER #63, BARREL THRUST WASHER #108 AND STRIKER CUSHION WASHER #109 WITH A MEDIUM COATING OF GREASE BEFORE ASSEMBLY.

10, 100 PRESS NEEDLE BEARING #10 IN ROD #100 SO THAT THE SAME AMOUNT STICKS OUT ON BOTH SIDES OF THE ROD, AS SHOWN.

9, 71 PRESS (2) NEEDLE BEARINGS #9 INTO HOLLOW CLUTCH SHAFT #71, FLUSH WITH THE ENDS OF THE SHAFT.

58, 70 PRESS CLUTCH PINION #58 FLUSH WITH THE END OF THE CLUTCH SHAFT #70.

11, 12, 46 PRESS NEEDLE BEARINGS #11 AND #12 FLUSH TO THE MACHINED FACES ON BOTH ENDS OF THE INTERMEDIATE HOUSING #46.

9, 44 PRESS NEEDLE BEARING #9 INTO CRANKCASE #44, FLUSH WITH TOP OF BORE, AS SHOWN.

81 LIGHTLY GREASE INSIDE OF BARREL #81 BEFORE ASSEMBLY.

48, 73 SMALL OUTSIDE DIAMETER OF SPINDLE #73 IS TO BE LUBRICATED WITH A LIGHT COAT OF GREASE BEFORE ASSEMBLING THE NOSE ASSEMBLY #48 TO THE TOOL.

48, 73, 102 NOSE ASSEMBLY #48 MUST BE PLACED SQUARELY OVER SPINDLE #73, WHEN ASSEMBLING, TO PREVENT DAMAGE TO OIL SEAL #102.

14, 19, 20, 23 FASTENERS #14, #19, #20 AND #23 ARE TO BE RE-ASSEMBLED USING BLUE LOCTITE.

48, 102 LUBRICATE BORE IN NOSE ASSEMBLY #48 BEFORE PRESSING OIL SEAL #102 INTO PLACE.

61, 66 LUBRICATE O-RINGS #61 AND #66 WITH GREASE.

69 INSTALL BEVEL SNAP RING #69 WITH BEVEL SIDE UP.

4, 50, 80 PLACE BEARING CUP #80 ON SMALL ARMATURE BEARING #4 BEFORE INSTALLING MOTOR COVER #50.

41 BRUSH SPRINGS #41 ARE TO BE WOUND 1/2 TURN TO ENGAGE BRUSHES.

4 RUBBER SEAL SIDE OF BALL BEARING #4 TO FACE FAN.

95, 98 FACES OF PISTON #95 AND RAM #98 ARE TO BE FREE OF GREASE.