



SERVICE PARTS LIST

BULLETIN NO.
55-22-1031

SPECIFY CATALOG NO. AND SERIAL NO. WHEN ORDERING PARTS		REVISED BULLETIN	DATE
6" STRAIGHT GRINDER			May '91
CATALOG NO. 5243-2	STARTING SERIAL NO. 663-6600	WIRING INSTRUCTION 58-01-0307	

EXAMPLE:
Component Parts (Small #) Are Included
When Ordering The Assembly (Large #).

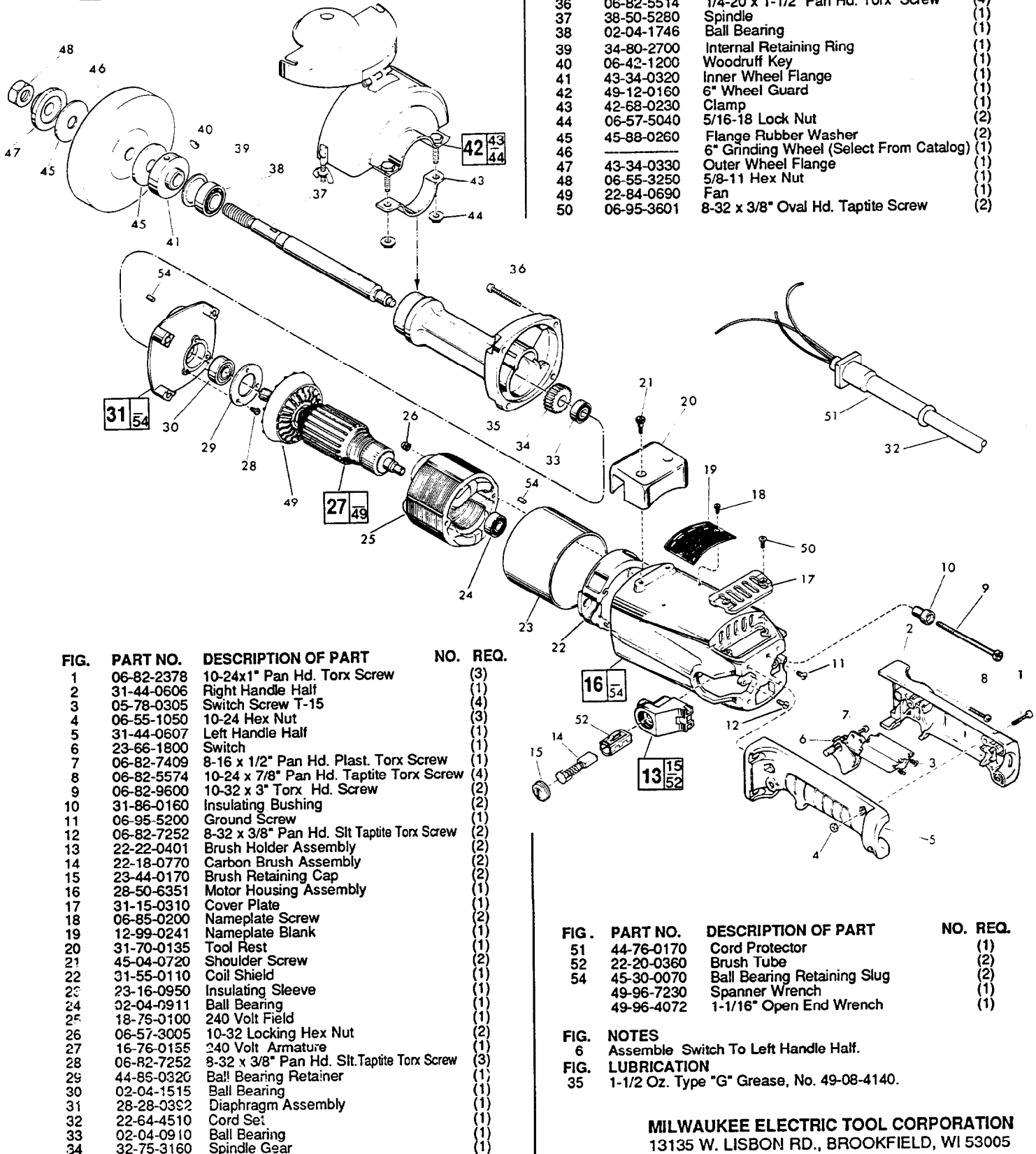

FIG.	PART NO.	DESCRIPTION OF PART	NO. REQ.
35	28-50-0400	Spindle Housing	(1)
36	06-82-5514	1/4-20 x 1-1/2" Pan Hd. Torx Screw	(4)
37	38-50-5280	Spindle	(1)
38	02-04-1746	Ball Bearing	(1)
39	34-80-2700	Internal Retaining Ring	(1)
40	06-42-1200	Woodruff Key	(1)
41	43-34-0320	Inner Wheel Flange	(1)
42	49-12-0160	6" Wheel Guard	(1)
43	42-68-0230	Clamp	(1)
44	06-57-5040	5/16-18 Lock Nut	(2)
45	45-88-0260	Flange Rubber Washer	(2)
46		6" Grinding Wheel (Select From Catalog)	(1)
47	43-34-0330	Outer Wheel Flange	(1)
48	06-55-3250	5/8-11 Hex Nut	(1)
49	22-84-0690	Fan	(1)
50	06-95-3601	8-32 x 3/8" Oval Hd. Tapite Screw	(2)

FIG.	PART NO.	DESCRIPTION OF PART	NO. REQ.
1	06-82-2378	10-24x1" Pan Hd. Torx Screw	(3)
2	31-44-0606	Right Handle Half	(1)
3	05-78-0305	Switch Screw T-15	(4)
4	06-55-1050	10-24 Hex Nut	(3)
5	31-44-0607	Left Handle Half	(1)
6	23-66-1800	Switch	(1)
7	06-82-7409	8-16 x 1/2" Pan Hd. Plast. Torx Screw	(1)
8	06-82-5574	10-24 x 7/8" Pan Hd. Tapite Torx Screw	(4)
9	06-82-9600	10-32 x 3" Torx Hd. Screw	(2)
10	31-86-0160	Insulating Bushing	(2)
11	06-95-5200	Ground Screw	(1)
12	06-82-7252	8-32 x 3/8" Pan Hd. Slit Tapite Torx Screw	(2)
13	22-22-0401	Brush Holder Assembly	(2)
14	22-18-0770	Carbon Brush Assembly	(2)
15	23-44-0170	Brush Retaining Cap	(1)
16	28-50-6351	Motor Housing Assembly	(1)
17	31-15-0310	Cover Plate	(1)
18	06-85-0200	Nameplate Screw	(2)
19	12-99-0241	Nameplate Blank	(1)
20	31-70-0135	Tool Rest	(1)
21	45-04-0720	Shoulder Screw	(2)
22	31-55-0110	Coil Shield	(1)
23	23-16-0950	Insulating Sleeve	(1)
24	02-04-0911	Ball Bearing	(1)
25	18-75-0100	240 Volt Field	(1)
26	06-57-3005	10-32 Locking Hex Nut	(2)
27	16-76-0155	240 Volt Armature	(1)
28	06-82-7252	8-32 x 3/8" Pan Hd. Slit Tapite Torx Screw	(3)
29	44-85-0320	Ball Bearing Retainer	(1)
30	02-04-1515	Ball Bearing	(1)
31	28-28-0392	Diaphragm Assembly	(1)
32	22-64-4510	Cord Set	(1)
33	02-04-0910	Ball Bearing	(1)
34	32-75-3160	Spindle Gear	(1)

FIG.	PART NO.	DESCRIPTION OF PART	NO. REQ.
51	44-76-0170	Cord Protector	(1)
52	22-20-0360	Brush Tube	(2)
54	45-30-0070	Ball Bearing Retaining Slug	(2)
	49-96-7230	Spanner Wrench	(1)
	49-96-4072	1-1/16" Open End Wrench	(1)

FIG. 6 NOTES
Assemble Switch To Left Handle Half.
FIG. LUBRICATION
35 1-1/2 Oz. Type "G" Grease, No. 49-08-4140.

MILWAUKEE ELECTRIC TOOL CORPORATION
13135 W. LISBON RD., BROOKFIELD, WI 53005