



SERVICE PARTS LIST

BUL. 54-22-9011

5" GRINDER

REVISED BUL 6156-2 DATE FEB. '68

Catalog No. 5220-8

Starting Serial No. 156-1340

WIRING INSTR.

Both Model and Serial No. must be furnished to obtain correct parts.

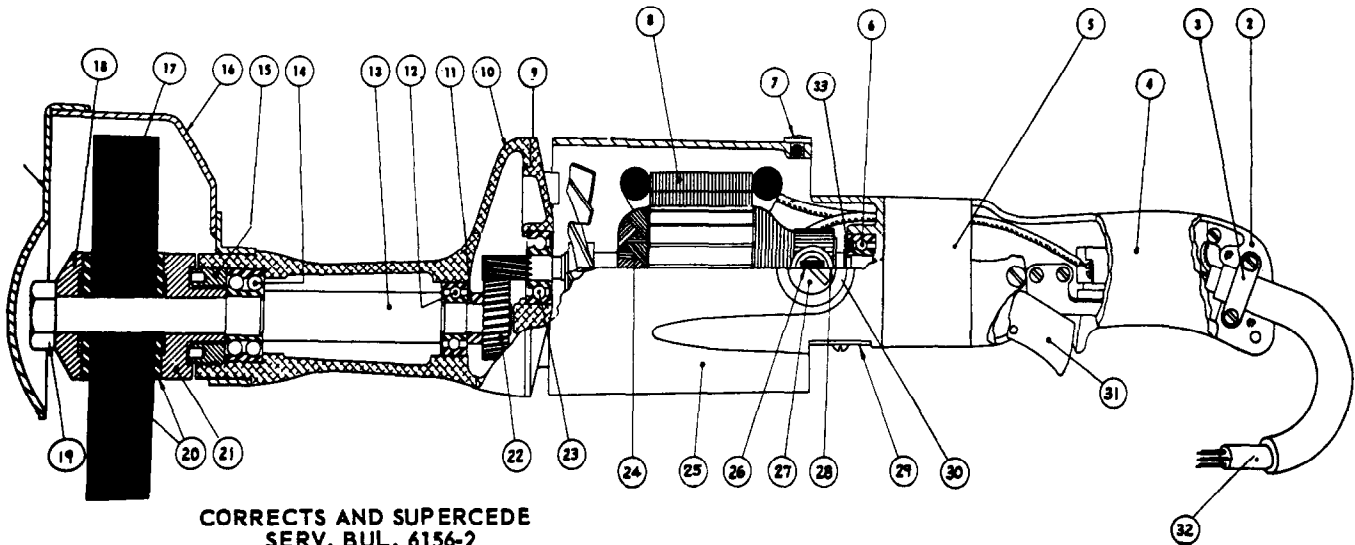

CORRECTS AND SUPERCEDES
SERV. BUL. 6156-2
DATED 3/1/62

ILLUSTRATED PARTS		
FIG.	PART NO.	DESCRIPTION OF PART
2	28-44-1041	Handle (Switch Mounting Side)
3	28-17-0200	Cord Clamp Strap
4	28-44-9081	Handle (Switch Cover Side)
5	23-62-0100	Radio Supp. Assembly
6	02-04-1070	Ball Brg. (Comm. End)
7	06-77-1400	Drive Screw Tool Rest Button
8	18-82-1170	Field Assembly
9	28-28-1021	Diaphragm
10	28-50-7601	Spindle Housing
11	45-36-0220	Spindle Gear Spacer
12	02-04-1520	Ball Brg. (Inner)
13	38-50-2051	Spindle
14	02-20-1720	Ball Brg. (Outer)
15	44-40-0180	Bearing Lock Nut
16	43-54-0110	5" Guard Assembly
17	49-92-2200	5" dia. x 3/4" x 1/2" Hole Grinding Wheel (24 Grit)
18	43-34-0050	Outer Wheel Flange
19	06-55-2850	1/2-13 Thr'd Spindle Nut
20	45-88-0190	Rubber Flange Washers (2)
21	43-34-0070	Inner Wheel Flange
22	32-75-2281	Spindle Gear
23	02-04-1140	Ball Brg. (Pinion End)
24	16-82-1460	Armature Assembly
25	28-50-4561	Motor Housing
26	22-18-0260	Carbon Brush Assemblies (per set 2)
27	23-44-0065	Brush Ret. Cap Assembly (per set 2)
28	22-22-0130	Brush Holder Assembly (2)
29	44-66-0100	Commutator Cover Plate
30	22-24-0100	Brush Holder Bushing (2)
31	23-66-0250	Switch Assembly
32	22-64-0160	Cord Set
33	43-06-0070	Grounding Disc

MISCELLANEOUS PARTS NOT SHOWN

PART NO.	DESCRIPTION OF PART	PART NO.	DESCRIPTION OF PART
28-79-0241	Tool Rest	06-97-3400	No. 10 Kantlink Lock Washer
12-30-3400	Name Plate	12-98-5100	Warning Plate
23-86-0130	Insulating Washers		
06-81-6100	No. 8-32x7/16 Fil. Hd. Cord Clamp Strap Sems (2)	06-97-2400	Lockwasher (4)
06-81-7150	No. 10-24x1-3/8 Fil. Hd. Spindle Housing Screws (4)	06-83-2650	1/4-20x3/8 Hdless. Brush Holder Set Screws (2)
06-81-3750	No. 8-32x1 Oval Hd. Handle Cover Screws	06-81-8950	No. 8-32x2-1/4 Rd. Hd. Field Screws (2)
06-81-3700	No. 8-32x7/8 Oval Hd. Handle Cover Screws	(2) 06-81-8625	No. 6-32x1/4 Rd. Hd. Ground Wire Screw (Brass)
06-81-1625	No. 12-24-2 1/4 Fil. Hd. Switch Handle Screws	(4) 06-81-8200	No. 4-36x3/16 Rd. Hd. Name Plate Sems (2)
12-98-5200	Identification Name Plate	06-81-8650	No. 6-32x1/4 Rd. Hd. Comm. Cover Screws (2)
06-77-0450	No. 4x1/4 Rd. Hd. Driv-in Screw	(2) 06-81-6950	No. 10-24x1/2 Fil. Hd. Tool Rest Sem (2)
06-97-3200	No. 8 Kantlink Lock Washer	06-81-5400	No. 8-32x 5/16 Binder Hd. Sw. Mounting Scs. (2)