

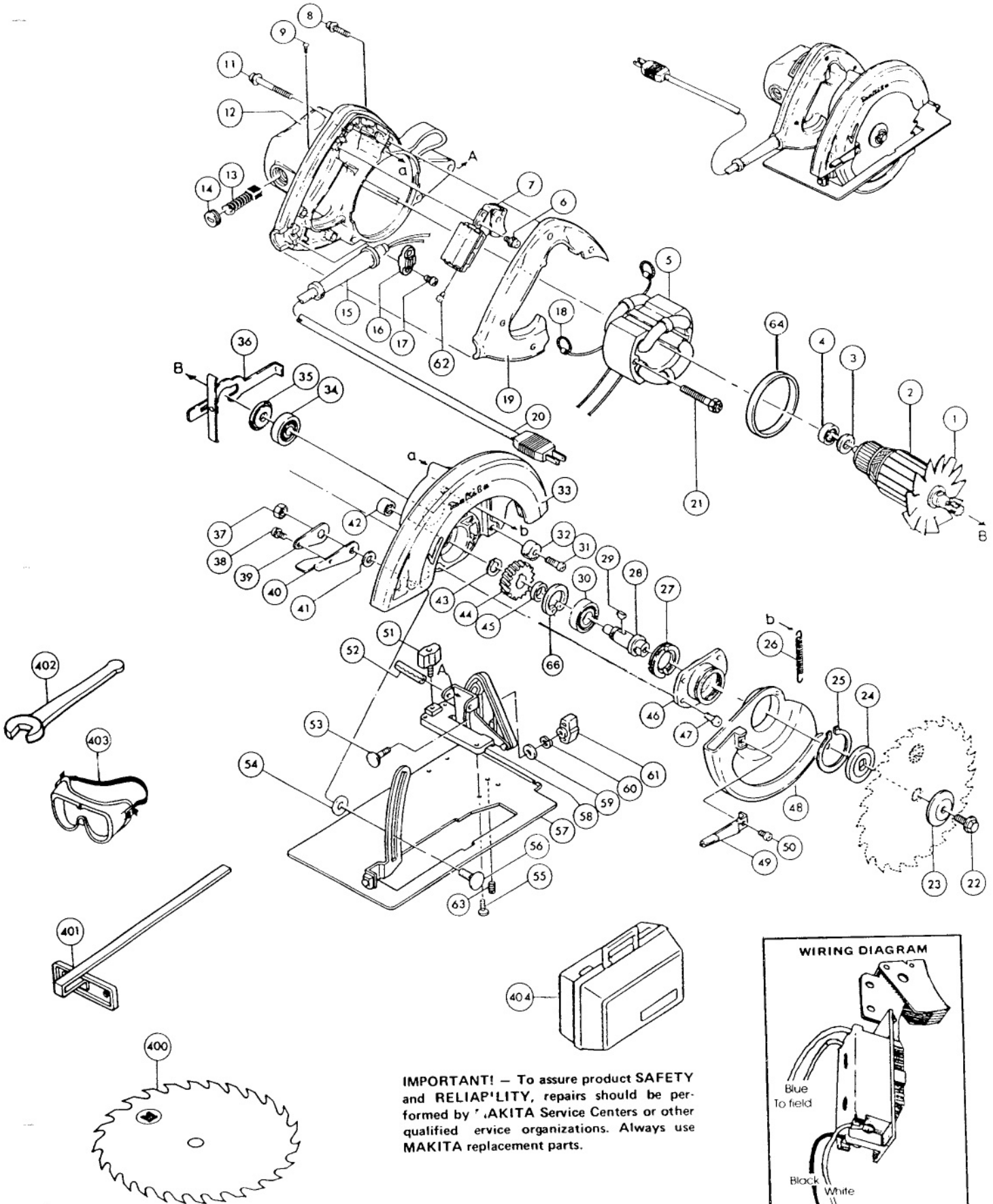

7-1/4" CIRCULAR SAW

Model 5007NB



IMPORTANT! — To assure product **SAFETY** and **RELIABILITY**, repairs should be performed by **MAKITA** Service Centers or other qualified service organizations. Always use **MAKITA** replacement parts.

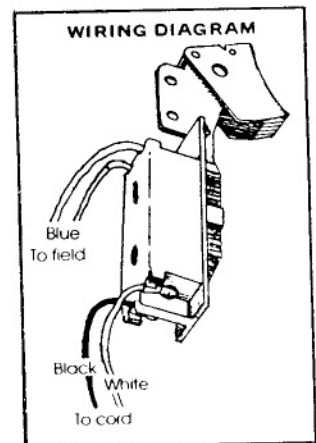
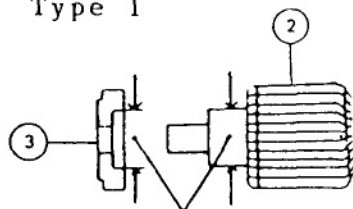

Fig.	Part No.	Qty. Used	Description	Fig.	Part No.	Qty. Used	Description
1	241005-3	1	FAN 92	37	931402-8	1	HEX NUT M8
2	*	1	ARMATURE (INCL. FIGS.1-4,34,35)	38	911106-8	1	P.H. SCREW M4X8
3	*	1	INS. WASHER	39	341415-5	1	LOCK PLATE
4	211033-2	1	B. BEARING 608LB	40	341416-3	1	LEVER PLATE
5	***	1	FIELD ASSY. (WITH FIG. 18)	41	941201-0	1	F. WASHER 8
6	*****	1	P. H. SCREW M4X12	42	212052-1	1	N. BEARING 1010
7	651121-7	1	SWITCH (AC/DC)	43	961055-9	1	RETAINING RING S-15
8	911148-2	4	P.H. SCREW M4X25	44	221647-9	1	HELICAL GEAR 39
9	953106-2	2	RIVET 0-5	45	257064-7	1	RING 15
11	911273-9	3	P.H. SCREW M5X50	46	****	1	BEARING BOX
12	***	1	MOTOR HOUSING (W/RUBBER PIN:263002-9 & 2 EA. B. HOLDER: 643653-8)	47	911126-2	4	P.H. SCREW M4X16
				48	*****	1	SAFETY COVER
13	181047-4	2	CARBON BRUSH (CB-154)	49	341417-1	1	LEVER
14	643650-4	2	BRUSH HOLDER CAP 6.5-13.5	50	*****	1	P.H. SCREW M4X10
15	682505-8	1	CORD GUARD 10-90	51	251858-2	1	SCREW M6X15
16	687001-1	1	STRAIN RELIEF	52	951225-8	1	SPRING PIN 6-40
17	*****	2	P.H. SCREW M4X18	53	251920-3	1	C.S.N. BOLT M6X30
18	654020-2	2	GARTER SPRING	54	253069-5	1	F. WASHER 12
19	411523-7	1	HANDLE COVER (W/4 EA. HEX NUT M4:931102-0)	55	912207-5	4	C.S.H. SCREW M5X10
20	664265-4	1	CORD WITH PLUG (2X16X8;S;J)	56	251918-0	1	C.S.N. BOLT M8X24
21	***	2	P.H. SCREW M5X55	57	**	1	BASE
22	251644-1	1	H.F.H. BOLT M8X20	58	**	1	ANGULAR PLATE
23	224275-9	1	OUTER FLANGE	59	941151-9	1	F. WASHER 6
24	224151-7	1	INNER FLANGE	60	942151-2	1	S. WASHER 6
25	961201-4	1	RETAINING RING S-42	61	252624-0	1	KNOB M6
26	231739-6	1	TENSION SPRING 4	62	652021-4	4	SWITCH SCREW
27	****	1	BEARING RETAINER 22-36	63	**	1	SCREW M5X12
28	323789-6	1	SPINDLE	64	***	1	FAN GUIDE
29	254032-1	1	WOODRUFF KEY 5	66	****	1	RETAINING RING
30	211206-7	1	B. BEARING 6202LLB	ACCESSORIES			
31	251247-1	1	P.H. SCREW M6X20	400	{ 721245-4	1	7 1/4" COMBINATION BLADE
32	262502-6	1	RUBBER SLEEVE 6		{ 721252-7	1	7 1/4" CARBIDE TIPPED BLADE
33	**	1	BLADE CASE (W/RING:213459-4)	401	164095-8	1	GUIDE RULE
34	211106-1	1	B. BEARING 6201LLB	402	781203-2	1	WRENCH 13
35	213102-5	1	DUST SEAL 12	403	191686-2	1	SAFETY GOGGLES
36	163113-9	1	SHAFT LOCK	404	824409-0	1	PLASTIC TOOL CASE

*SEE SERVICE CHANGE 1
 **SEE SERVICE CHANGE 2
 ***SEE SERVICE CHANGE 3
 ****SEE SERVICE CHANGE 4
 *****SEE SERVICE CHANGE 5
 *****SEE SERVICE CHANGE 6

1. Change on the Insulation Washer.

Type 1



14mm Diameter

Type 2

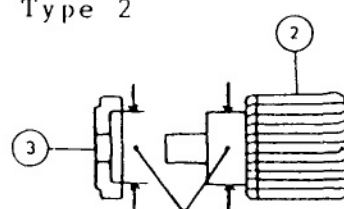

16mm Diameter

Fig.	Description	Type 1	Type 2
2	Armature	Part # 614586-4 (Discontinued)	Part # 614856-1 (See Service Change 3)
3	Insulation Washer	Part # 681613-2	Part # 681625-5

The above parts are completely interchangeable as a set.

SERVICE CHANGE

2. Change on Blade Case, Base and Angular Plate

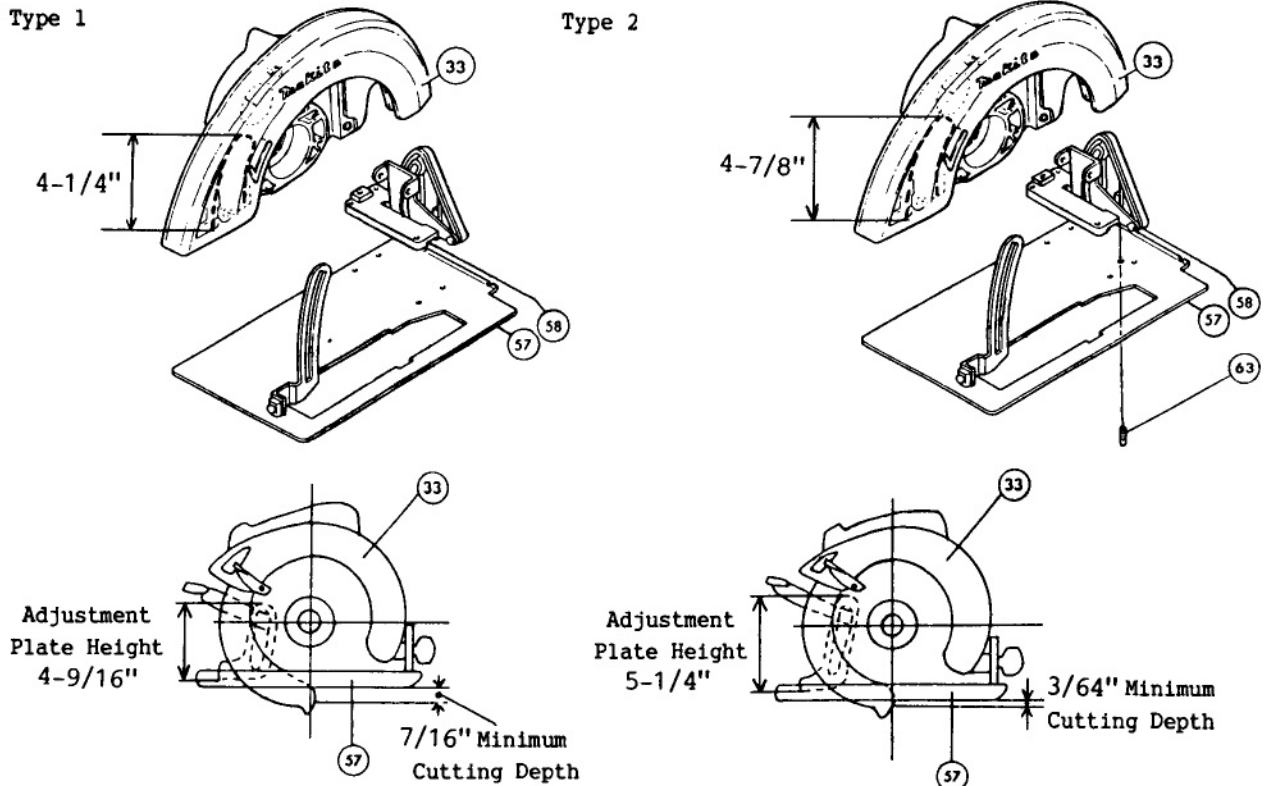

FIG. NO.	DESCRIPTION	TYPE 1	TYPE 2	TYPE 3
33	BLADE CASE	PART #154254-2 (DISCONTINUED)	PART #154321-3	-----
57	BASE	PART #163177-3	PART #163249-4	-----
58	ANGULAR PLATE	PART #1631781	PART #163248-6	-----
63	SCREW M5X12	-----	PART #265882-9 SLOTTED (DISCONTINUED)	PART #266180-4 PHILLIPS

The above parts are completely interchangeable as a set.
 Type 2 Angular Plate can be used as Type 1 Angular Plate.
 Type 2 Blade Case can be used as Type 1 Blade Case.

SERVICE CHANGE

3. Change on Motor from S/N 208355-208642, 220163-222502, 241299-244934, 248103-249650, 254691-255266, 258975-259298, 261495-266426, 267543-268478, 270963-274946, 277875 and beyond.

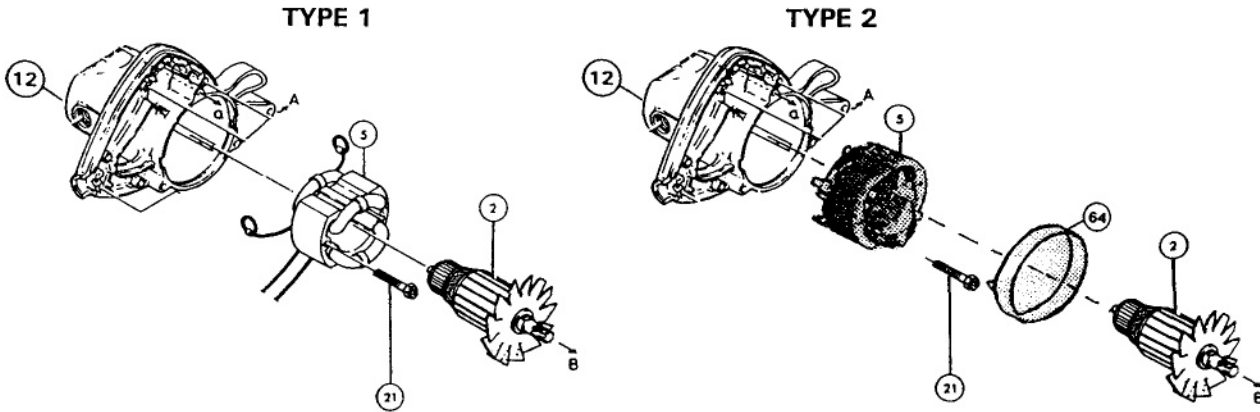

FIG.	DESCRIPTION	TYPE 1	TYPE 2
2	Armature	Part #614856-1	Part #616606-0
5	Field	Part #624536-1	Part #636066-0
12	Motor Housing	Part #156465-5	Part #159741-6
21	P.H. Screw M5x55	Part #911280-2	Part #911676-7 (w/Washer)
64	Fan Guide	-----	Part #415603-1

The above parts are completely interchangeable as a set except Type 2 Motor Housing replaces T1 Motor Housing individually.

4. Change on Bearing Box.

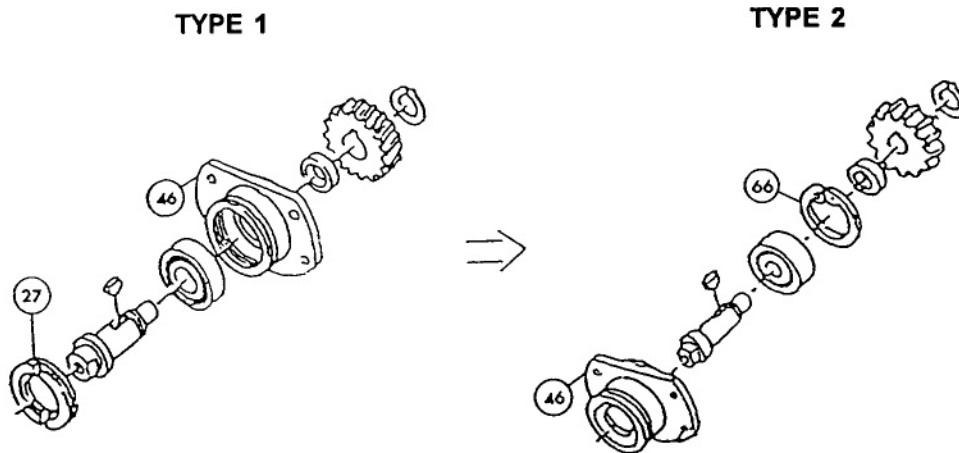

Fig.	Description	Type 1	Type 2
27	Bearing Retainer	Part # 285807-7	----
46	Bearing Box	Part # 321061-0 (Discontinued)	Part # 316700-5
66	Retaining Ring	----	Part # 962153-2

The above parts are completely interchangeable as a set.

SERVICE CHANGE

5 Change on Safety Cover and Screw.

TYPE 1
With Hole
(for fig. 50 screw) → **TYPE 2**
Without Tapped Hole
(for fig. 50 screw)

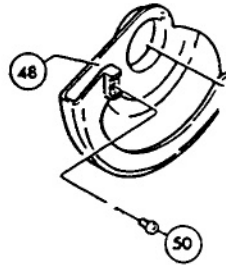

Fig.	Description	Type 1	Type 2
48	Safety Cover	Part #315040-8 (Discontinued)	Part #316962-5
50	Screw	Part #911111-5 (Pan Head M4x10)	Part #266061-2 (Tapping CT4x8)

The above parts are interchangeable as a set.

6) **Service Change**

The Screws have been changed to Tapping Screws.

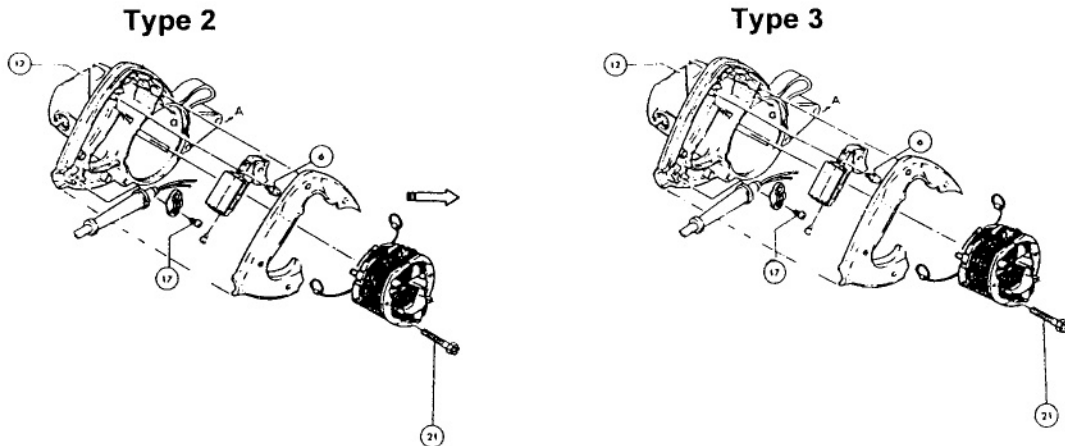

Fig.	Description	Type 2	Type 3
6	SCREW	Part #911119-9 Pan Head M4x12	Part #266020-6 Tapping 4x12
12	MOTOR HOUSING	Part #159741-6 (Discontinued)	Part #151554-1 SEE SERVICE CHANGE 6
17	SCREW	Part #911131-9 Pan Head M4x18	Part #265995-6 Tapping 4x18
21	SCREW	Part #911676-7 Pan Head M5x55	Part #266046-8 Tapping 5x50 SEE SERVICE CHANGE 6

The above parts are completely interchangeable.